

P-SERIES Pressure Switches

Switches for Vacuum through 6000 psig with Adjustable Set Points and Fixed or Adjustable Deadband

Features:

- Set point repeatability, $\pm 1\%$ of operating range.
- All wiring terminals, adjustments and visual scales are accessible from the front of the switch.
- Choice of open frame type, general purpose or watertight enclosure.
- Choice of fixed, limited-adjustable or full-range adjustable deadband.
- Choice of single or two-stage units.
- Compact size.
- Mounts in any position.
- Rugged and vibration resistant; e.g., for compressors.
- Visual adjustment scales in psig and bars.
- Wide selection of transducer wetted materials suitable for air, water, oil or corrosive fluids.
- Mix and match switch and transducer components for increased stock flexibility or to change pressure ranges in field.

General Description:

ASCO P-Series pressure switches consist of an open frame or enclosure protected switch unit and a transducer unit. They can be ordered separately for customer stocking and/or field assembly or as a complete factory-assembled unit.

Switch

P-Series pressure switch units incorporate the unique ASCO TRI-POINT alternating fulcrum balance plate to control the operation of one or more electrical snap-action switches. The electrical snap-action switch together with the adjusting mechanism is a fully-tested, self-contained subassembly.

Transducer

Transducer unit incorporates a diaphragm/piston type pressure sensor, and is also a fully-tested, self-contained subassembly.

Operation

When pressure is applied to the transducer it is converted into movement of the piston. This piston movement is then used to control the operation of the electrical snap-action switch in the switch unit.

Options (See pages 34-35)



Standard Electrical Ratings

PA, PB, PC ① Series

- 15 Amp Res., 125 VAC
- 10 Amp Res., 250 VAC
- 1/8 HP, 125 VAC
- 1/4 HP, 250 VAC
- 1/2 Amp Res., 125 VDC
- 1/4 Amp Res., 250 VDC

PG Series

- 15 Amp Res., 125 VAC
- 10 Amp Res., 250 VAC
- 1/8 HP, 125 VAC
- 1/4 HP, 250 VAC

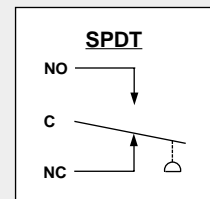

- ① PC Series, UL recognized component, rated 10 Amp Res., 125/250 VAC; 1/3 HP 125/250 VAC.
- ② Open frame construction, UL recognized component.
- ③ FM listed for air flow interlocking service.

Standard Temperature Ratings

- Ambient:** -4°F (-20°C) to 122°F (50°C)
- Fluid:**
 - For Buna "N" or Neoprene Diaphragm: -4°F (-20°C) to 180°F (82°C)
 - For Viton Diaphragm: -4°F (-20°C) to 250°F (121°C)
 - For 316 SS Diaphragm: -50°F (-45°C) to 300°F (149°C)
 - For Nylon Transducers: -4°F (-20°C) to 180°F (82°C)

Enclosures

ASCO TRI-POINT switches are available in either a general purpose or watertight enclosure, in addition to open frame construction. These enclosed units are made in accordance with NEMA and UL standards. These standards define the protection level an enclosure gives and the tests it must pass to meet a particular design.

General Purpose – Type 1. These enclosures are designed for indoor use to protect personnel from accidental contact with the equipment. P-Series general purpose enclosures are painted, zinc-coated

steel and have a 7/8" diameter hole at the top for electrical entry.

Watertight – Type 4. Watertight and dust-tight enclosures are intended for use indoors and outdoors to protect the enclosed equipment against splashing or falling water, windblown dust and water, hose directed water, and severe external condensation. P-Series watertight switch enclosures are epoxy-painted, zinc-coated steel with a 1/2" conduit hub in the side of the lower housing for electrical entry. (For optional 316 SS watertight enclosure see page 13.)

Dimensions (inches)

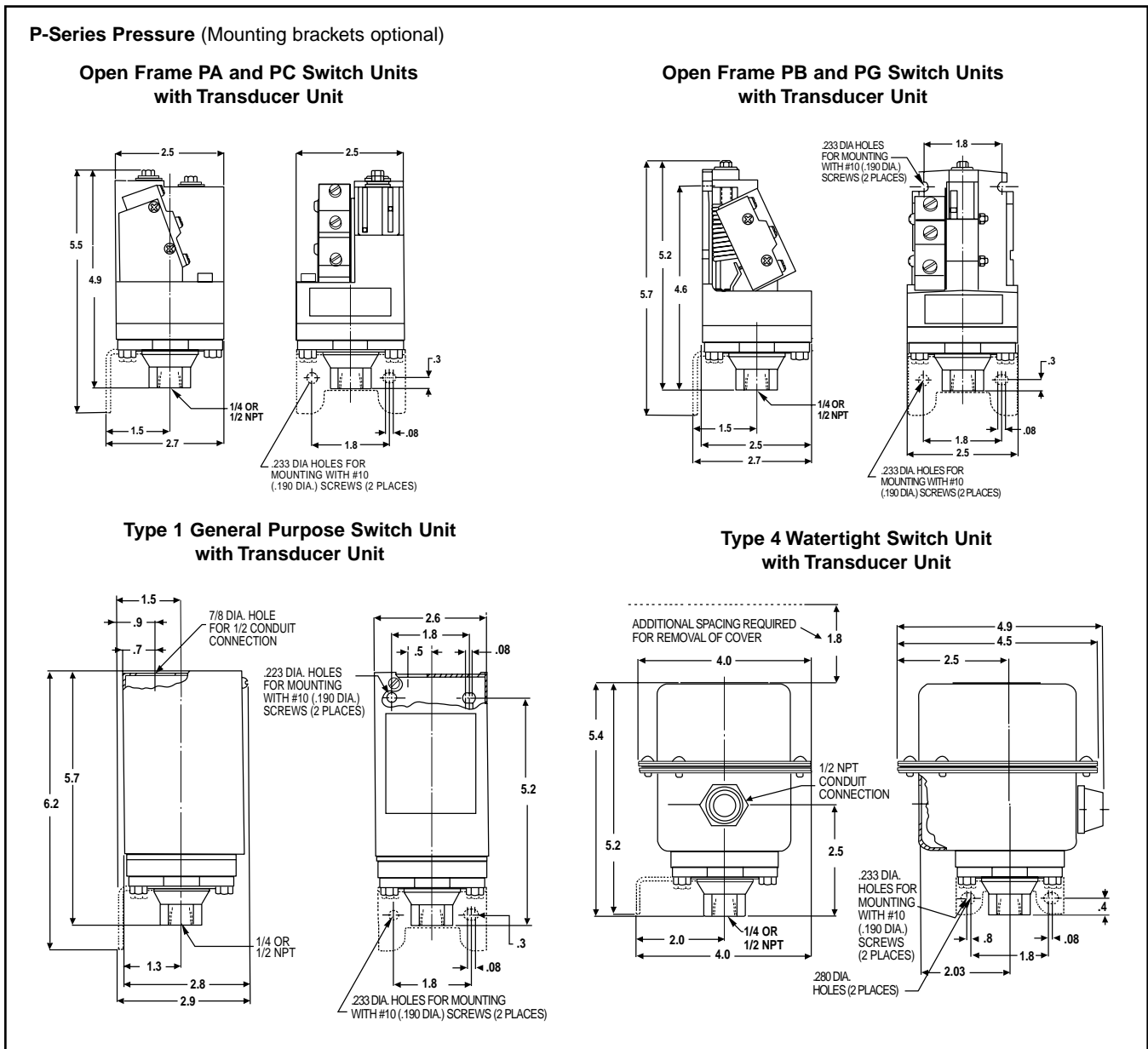



General Purpose Enclosure



Watertight Enclosure

How to Select and Order

ASCO P-Series switches consist of two components, the switch unit and the transducer unit.

How to Select

1. Select the adjustable operating range based on desired actuation pressure.
2. Check that proof pressure is sufficient.
3. Read across and select the desired P-Series switch unit with the proper enclosure.
4. Continue across and select a matching transducer unit compatible with the fluid.

How to Order

Factory assembled – Simply order the switch and transducer unit by catalog number joined by a slash (/), e.g., PA36A/RD30A11.

Field assembled – Simply order the switch and transducer units separately by individual catalog number, e.g., one PA36A and one RD30A11.

Options – Add appropriate suffix for desired option or accessory (see pages 34-35).

Important Note: The third digit of each of the catalog numbers must be identical, e.g., PA [3]6A and RD [3]0A11.

Select transducer unit below





Standard connection is 1/4" NPT
(optional 1/2" NPT add suffix "B" to catalog number)

Transducer Unit

These **gauge pressure type transducers** provide for one pressure connection in the bottom of the transducer. They are diaphragm/piston type transducers using an elastomer in contact with the fluid, backed by a piston cylinder. This allows high sensitivity for low pressures and strength for high pressures.

PA, PB, or PC unit below

PA Switch Unit	PB Switch Unit	PC Switch Unit
<p>Single-Stage Adjustable Deadband units allow independent adjustment of the set and reset points over the full operating range of the switch. The minimum difference between set and reset points is the deadband listed below; the maximum difference is the full range of the switch.</p>  <p>Open Frame</p>	<p>Single-Stage Fixed Deadband units have an adjustable set point and a non-adjustable automatic reset point.</p>  <p>Open Frame</p>	<p>Two-Stage Fixed Deadband units consist of two separate snap-action switches, each with an independently adjustable set point and non-adjustable reset point. The difference between the set and reset points of each switch is the deadband listed below; the minimum difference between the set points of the two switches is the separation.</p>  <p>Open Frame</p>

Specifications		Adjustable Deadband				Fixed Deadband				Two-Stage Fixed Deadband					Transducer Units						
Adjustable Operating Range (psig)	Proof Pressure (psig)	Adjustable Deadband Maximum Full Scale	Minimum At Mid-Range (psig) ①	Open Frame	General Purpose	Watertight Enclosure	Fixed Deadband At Mid-Range (psig) ①	Open Frame	General Purpose	Watertight Enclosure	Fixed Deadband At Mid-Range (psig) ①	Separation Maximum Full Scale	Minimum At Mid-Range (psig) ①	Open Frame	General Purpose	Watertight Enclosure	Air or Gas ②	Air, Oil or Gas	Water, Air, Oil or Gas	Corrosive Fluids	
																				Catalog No.	Catalog No.
Vacuum 0 - 30" Hg	50	4" Hg	PA36A	PA30A	PA31B	1" Hg	PB36A	PB30A	PB31B	2.7" Hg	3" Hg	PC36A	PC30A	PC31B	---	RV34A11	RV34A21	---	---	RV34A32	
Compound Pressure 30"Hg - 14 psig	50	6" Hg	PA26A	PA20A	PA21B	1" Hg	PB26A	PB20A	PB21B	4.3" Hg	6" Hg	PC26A	PC20A	PC21B	---	RV24A11	RV24A21	---	---	RV24A32	
0 - 4	60	---	---	---	---	0.05	PB46A	PB40A	PB41B	---	---	---	---	---	RD40A71	RD40A11	RD40A21	---	---	RD40A42	
0 - 9	60	1.2	PA36A	PA30A	PA31B	0.4	PB36A	PB30A	PB31B	0.6	1.0	PC36A	PC30A	PC31B	RD30A71	RD30A11	RD30A21	---	---	RD30A42	
2 - 18	60	1.8	PA26A	PA20A	PA21B	0.4	PB26A	PB20A	PB21B	0.8	1.8	PC26A	PC20A	PC21B	RD20A71	RD20A11	RD20A21	---	---	RD20A42	
2 - 18	100	2.5	PA36A	PA30A	PA31B	0.6	PB36A	PB30A	PB31B	1.2	1.8	PC36A	PC30A	PC31B	---	---	---	RE30A44	---	---	
4 - 36	150	4.0	PA26A	PA20A	PA21B	0.7	PB26A	PB20A	PB21B	2.0	3.6	PC26A	PC20A	PC21B	RE20A71	RE20A11	RE20A21	RE20A44	RE20A42	RE10A42	
6 - 60	150	5.4	PA16A	PA10A	PA11B	0.9	PB16A	PB10A	PB11B	2.4	6.0	PC16A	PC10A	PC11B	RE10A71	RE10A11	RE10A21	RE10A44	RE10A42	RF10A42	
10 - 100	200	9	PA16A	PA10A	PA11B	1.5	PB16A	PB10A	PB11B	4	10	PC16A	PC10A	PC11B	RF10A71	RF10A11	RF10A21	RF10A44	RF10A42	RG10A42	
20 - 200	400	18	PA16A	PA10A	PA11B	3.0	PB16A	PB10A	PB11B	8	20	PC16A	PC10A	PC11B	RG10A71	RG10A11	RG10A21	RG10A44	RG10A42	RH10A42	
30 - 300	450	27	PA16A	PA10A	PA11B	5.0	PB16A	PB10A	PB11B	12	30	PC16A	PC10A	PC11B	---	RH10A11	RH10A21	RH10A44	RH10A42	---	
40 - 400	500	36	PA16A	PA10A	PA11B	6	PB16A	PB10A	PB11B	16	40	PC16A	PC10A	PC11B	---	RJ10A11	RJ10A21	RJ10A44	RJ10A42	---	
60 - 600	2000	54	PA26A	PA20A	PA21B	12	PB26A	PB20A	PB21B	30	60	PC26A	PC20A	PC21B	---	---	RL20A21	---	---	RL20A42	
100 - 1000	2000	90	PA16A	PA10A	PA11B	15	PB16A	PB10A	PB11B	40	100	PC16A	PC10A	PC11B	---	---	RL10A21	---	---	RL10A42	
160 - 1650	5000	250	PA26A	PA20A	PA21B	100	PB26A	PB20A	PB21B	200	300	PC26A	PC20A	PC21B	---	---	RN20B21	---	---	RN20B42	
270 - 2700	5000	300	PA16A	PA10A	PA11B	125	PB16A	PB10A	PB11B	250	400	PC16A	PC10A	PC11B	---	---	RN10B21	---	---	RN10B42	
600 - 6000	9000	650	PA16A	PA10A	PA11B	200	PB16A	PB10A	PB11B	400	600	PC16A	PC10A	PC11B	---	---	---	---	---	RQ10B42	

All switch units above are in stock for immediate delivery.

All switch units and transducer units above are in stock for immediate delivery.

① Values shown are nominal. ② Rated proof pressure on RF10A71 is 150 psig and on RG10A71 is 300 psig.

③ 316 SS transducer deadbands are approx. 50% greater than listed. ④ Transducers ending in 32 have 303 SS process connections, not 316 SS.

P-SERIES Pressure Switches

How to Select and Order



ASCO P-Series switches consist of two components, the switch unit and the transducer unit.

How to Select

1. Select the adjustable operating range based on desired actuation pressure.
2. Check that rated proof pressure is sufficient.
3. Read across and select the desired P-Series switch unit with the proper enclosure.
4. Continue across and select a matching transducer unit compatible with the fluid.

How to Order

Factory assembled – Simply order the switch and transducer unit by catalog number joined by a slash (/), e.g., PG36A/RV34A11.
Field assembled – Simply order the switch and transducer units separately by individual catalog number, e.g., one PG36A and one RV34A11.
Options – Add appropriate suffix for desired option (see pages 34-35).
Important Note: The third digit of each of the catalog numbers must be identical, e.g., PG 36A and RV 34A11.

Select P-Series switch unit and transducer unit below										
PG Switch Unit			Transducer Unit							
<p>Limited Adjustable Deadband units have an adjustable set point and use a special snap-action switch that varies the deadband within the limits listed below.</p>  <p>Open Frame</p>			<p>These gauge pressure type transducers are diaphragm/piston type transducers using an elastomer in contact with the fluid, backed by a piston cylinder. This allows high sensitivity for low pressures and strength for high pressures.</p>  <p>Standard port connection is 1/4" NPT (optional 1/2" NPT add suffix "B" to catalog number)</p>							
Specifications		Limited Adjustable Deadband				Transducer Units				
Adjustable Operating Range (psig)	Proof Pressure (psig)	Adjustable Deadband At Mid-Range (psig) ① From/To	Open Frame Catalog No.	General Purpose Catalog No.	Watertight Enclosure Catalog No.	Air or Gas ②	Air, Oil or Gas	Water, Air, Oil or Gas	Corrosive Fluids	
						Nylon & Buna "N"	Aluminum & Buna "N"	Brass & Buna "N"	All 316 SS ③	316 SS & Viton ④
						Catalog No.	Catalog No.	Catalog No.	Catalog No.	Catalog No.
Vacuum 0 - 30" Hg	50	1.8 - 5.0	PG36A	PG30A	PG31B	---	RV34A11	RV34A21	---	RV34A32
Compound 30"Hg-14 psig Pressure	50	2.8 - 6.0	PG26A	PG20A	PG21B	---	RV24A11	RV24A21	---	RV24A32
0 - 9	60	0.7 - 1.3	PG36A	PG30A	PG31B	RD30A71	RD30A11	RD30A21	---	RD30A42
2 - 18	60	0.8 - 2.1	PG26A	PG20A	PG21B	RD20A71	RD20A11	RD20A21	---	RD20A42
2 - 18	100	1.8 - 3.1	PG36A	PG30A	PG31B	---	---	---	RE30A44	---
4 - 36	150	2.0 - 4.0	PG26A	PG20A	PG21B	RE20A71	RE20A11	RE20A21	RE20A44	RE20A42
6 - 60	150	2.1 - 4.6	PG16A	PG10A	PG11B	RE10A71	RE10A11	RE10A21	RE10A44	RE10A42
10 - 100	200	4 - 8	PG16A	PG10A	PG11B	RF10A71	RF10A11	RF10A21	RF10A44	RF10A42
20 - 200	400	8 - 17	PG16A	PG10A	PG11B	RG10A71	RG10A11	RG10A21	RG10A44	RG10A42
30 - 300	450	15 - 25	PG16A	PG10A	PG11B	---	RH10A11	RH10A21	RH10A44	RH10A42
40 - 400	500	22 - 45	PG16A	PG10A	PG11B	---	RJ10A11	RJ10A21	RJ10A44	RJ10A42
60 - 600	2000	35 - 75	PG26A	PG20A	PG21B	---	---	RL20A21	---	RL20A42
100 - 1000	2000	65 - 110	PG16A	PG10A	PG11B	---	---	RL10A21	---	RL10A42
160 - 1650	5000	190 - 290	PG26A	PG20A	PG21B	---	---	RN20B21	---	RN10B42
270 - 2700	5000	200 - 300	PG16A	PG10A	PG11B	---	---	RN10B21	---	RN10B42
600 - 6000	9000	300 - 500	PG16A	PG10A	PG11B	---	---	---	---	RQ10B42

All switch units and transducer units above are in stock for immediate delivery.

① Values shown are nominal. ② Rated proof pressure on RF10A71 is 150 psig and on RG10A71 is 300 psig.

③ 316 SS transducer deadbands are approx. 50% greater than listed. ④ Transducers ending in 32 have 303 SS process connections, not 316 SS.

Switches with Optional 316 Stainless Steel Enclosure

Every ASCO P-Series pressure switch is available in a corrosion-resistant, stainless steel enclosure. Typical applications include:

- Offshore platforms
- Hydrocarbon processing plants
- Oil & gas fields
- Oil & gas transmission lines
- Chemical plants
- Breweries
- Paper pulp mills
- Salt spray locations

Stainless Steel Enclosure

ASCO Type 4X watertight enclosure is designed to provide protection against windblown dust, rain, sleet or external ice formation. The switch and transducer unit are available only as factory-assembled units, and include a UL-approved 1/2" NPT conduit hub.



How to Select and Order

ASCO P-Series switches with 316 SS enclosure consist of two factory-assembled components, the switch unit and the transducer unit.

How to Select (use tables on pages 10-12)

1. Select the adjustable operating range based on desired actuation pressure.
2. Check that rated proof pressure is sufficient.
3. Read across and select the desired P-Series switch unit with open frame construction.
4. To add a 316 SS enclosure, change the fourth digit of the open frame catalog number from "6" to "4", e.g., PG3 [6] A becomes PG3 [4] A.
5. Continue across and select a matching transducer unit compatible with the fluid.

How to Order

Factory assembled only – Simply order the switch and transducer unit by catalog number joined by a slash (/), e.g., PG34A/RV34A32.

Options – Add appropriate suffix for desired option (see pages 34-35).

Dimensions (inches)

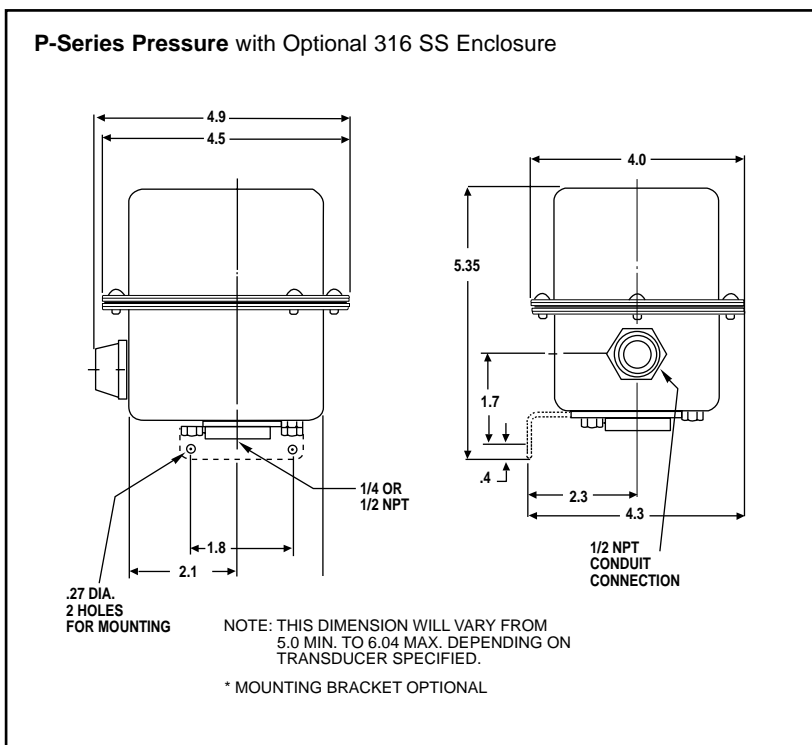

OPTIONS Pressure/Temperature Switches

H-Series, P-Series and S-Series Snap-Action Switch Options

Optional snap-action switches to meet specific electrical loads or application conditions are available on most ASCO TRI-POINT switch units. Generally, the construction of a switch unit with optional snap-action switches contains other specific parts and may be ordered only as a factory-built unit. To specify a particular optional construction, add the appropriate suffix to the switch unit catalog number, e.g., SA10D with optional gold contact snap-action switch (suffix "P") would become SA10D[P].

P-Series Switch Options

Panel Mount – Open frame P-Series compact switch units are available for panel mounting with the switch unit inside and the transducer outside. The panel separates the fluid sensing portion from the electromechanical portion. Five holes for bolts and operating stem must be drilled or punched through the panel. Three constructions are available: add the suffix listed below to the switch unit catalog number for the desired thickness.

Description	Electrical Rating	Catalog Suffix	Deadband Variation From Listing
DC Rating 1 Amp Double Break	5 Amp, 125, 250 VAC 1/4 HP, 125 VAC 1/2 HP, 250 VAC 1 Amp, 125 VDC 1/2 Amp, 250 VDC	G	SA: +50% SB, SC, PA: +100% H: +200% PB: +400%
DC Rating 10 Amps, SPDT	10 Amp, 125 VAC, VDC 1/8 HP, 125 VAC, VDC	M	SA: +50% SB, SC, PA: +100% H: +120% PB: +400%
Double-pole Double-throw (Two SPDT Switches with Common Lever) Gold Contact Dry Circuit SPDT	5 Amp, 125, 250 VAC 1/8 HP, 125 VAC 1/4 HP, 250 VAC 1/2 Amp, 125 VDC 1/4 Amp, 250 VDC 1 Amp, 28 VAC 1 Amp, 28 VDC	K P	SA, SB, SD, SE, PB: +50% SA, SB, SC, PA: +25% H: +50% PB, PC: +100%
Hermetically Sealed SPDT	25 Amp Res, 28 VDC 10 Amp Ind, 28 VDC 5 Amp Motor, 28 VDC 3 Amp Lamp, 28 VDC 1 Amp, 125 VAC	H	SA, PA: +100% H: +200% PB: +600%
High Ambient 250°F SPDT	5 Amp, 125, 250 VAC 1/8 HP, 125 VAC 1/4 HP, 250 VAC 1/2 Amp, 125 VDC 1/4 Amp, 250 VDC 20 Amp, 125, 250 VAC	F	SA, SB, SC: +25%
High Power 1 HP SPDT	1 HP, 125 VAC 2 HP, 250 VAC 1/2 Amp, 125 VDC 1/4 Amp, 250 VDC	W	SA: +50% SB, SC: +100% PB: +400%
Moisture Resistant Sealed Switch SPDT	5 Amp, 125, 250 VAC 1/8 HP, 125 VAC 1/4 HP, 250 VAC 1/2 Amp, 125 VDC 1/4 Amp, 250 VDC	J	SA: None SB, SC, PA: +25% PB, H: +50%
Tight Fixed Deadband SPDT	5 Amp, 125, 250 VAC 1/8 HP, 125 VAC 1/4 HP, 250 VAC 1/2 Amp, 125 VDC	T	SB, SC: -50%

Panel Thickness	Suffix
10 Ga (.135±.005)	10
14 Ga (.075±.005)	11
16 Ga (.060±.005)	12

S-Series Switch Options

Industrial Adjusting Nut Covers – Available in clear plastic or metal to prevent tampering with set point adjusting nuts.

Clear plastic cover: To order, add suffix "1" to the switch unit catalog number, or order separately as SP01.
Metal cover: To order, add suffix "2" to the switch unit catalog number, or order separately as SP02.

JIC Construction – A switch unit having the electrical and adjusting nut covers attached to the switch body by a chain. Also designed to Type 13 specifications. To order, add suffix "3" to the switch unit catalog number, or order separately as SP03.

Terminal Block – Applicable to switch units with one single-poledouble-throw switch. The terminal strip is prewired to the snap-action switch. To order, add suffix "4" to the switch unit catalog number, or order separately as SP04.

Factory Sealed – Explosion-proof units may be ordered with a factory seal separating the electrical chamber from the conduit hubs and 24" long #14 AWG 105°C. rated lead wires. To order, change the fourth digit of the switch unit catalog number from "2" to "3", e.g., SA1[2]D becomes SA1[3]D.

Pressure Transducer Options

Special Wetted Materials – The following diaphragms may be substituted on transducer body materials of aluminum, brass, polyester and stainless steel. To order, substitute the material code below in the seventh digit of the transducer catalog number, e.g., a TF10A1 [1] with optional viton diaphragm becomes a TF10A1 [2].

Diaphragm	Material Code	Temperature Range
Buna "N"	1	-4°F (-20°C) to 180°F (82°C)
Ethylene Propylene	6	-4°F (-20°C) to 250°F (121°C)
Neoprene	3	-4°F (-20°C) to 180°F (82°C)
Fluorosilicone	7	-40°F (-40°C) to 250°F (121°C)
Viton	2	-4°F (-20°C) to 250°F (121°C)

Oxygen Cleaning – Pressure transducers for oxygen service should be specially cleaned. They are degreased and blacklight inspected, then assembled in a clean area and tested with oil-free air or nitrogen. Use metal body transducer with viton or neoprene diaphragm and add suffix "H" to transducer catalog number, e.g., TA40A13 becomes TA40A13 [H].

Pressure Snubbers – A pressure snubber (1/4" NPTF by 1/4" NPTM) installed in the transducer pressure connection will dampen the pressure spikes to a value which will not cause damage. It consists of a body with a porous metal disc of stainless steel through which the fluid passes. To order, select a snubber compatible with the fluid. Available by separate catalog number only (see table below).

Fluid	Brass Catalog No.	303 SS Catalog No.
Air, Non-Hazardous Gases	TP04G2	TP04G3
Water, Light Oil (under 225 SSU)	TP04E2	TP04E3
Oil (Heavy, (over 225 SSU)	TP04D2	TP04D3
Pressure Rating (psig)	2000	5000

Process Connection – A female process connection (1/4" NPT) is standard on all pressure transducers. A 1/2" NPT is available as an option on *gauge* pressure transducers. To order, add suffix "B" to transducer catalog number, e.g., RF10A21 becomes RF10A21 [B].

Note: Not available on nylon transducers.

P-Series and S-Series Temperature Transducer Options

Armored Capillaries – Double braided copper armor is standard for copper capillary units. Stainless steel spiral interlocked armor is available for stainless steel capillary units. Add suffix "C" to transducer catalog number.

Thermal Well



Thermal Well ① – Use with direct or remote sensors for protecting sensing bulb. This allows removal of bulb while maintaining a pressure-tight vessel. Available in 1/2" NPT or 3/4" NPT process connection in brass or 316 SS. Dimensions are in accordance with SAMA Std. RC17-9. Standard "U" dimension (insertion length) is 2-1/2" for direct mount and 6' capillary units and is 4-1/2" for 12' capillary units.

Material	Pressure Rating (psig)	"U" Dimensions (Inches)	Process Connection	
			1/2" NPT Catalog No.	3/4" NPT Catalog No.
Brass	1000	2-1/2	QP03	QP04
		4-1/2	QP13	QP14
		7-1/2	QP23	QP24
		10-1/2	QP33	QP34
316 SS	6000	2-1/2	QP07	QP08
		4-1/2	QP17	QP18
		7-1/2	QP27	QP28
		10-1/2	QP37	QP38

Longer Capillaries – Standard copper and stainless steel capillary units can be furnished in 12' lengths. To order, add suffix "D" to transducer catalog number.

Consult ASCO for longer length capillaries.

Capillary Length (Feet)	Transducer Suffix	Bulb Length (Inches)	"U" Dimension Required (Inches)
6	---	3-1/2	2-1/2
12	D	5-1/2	4-1/2
13 - 20	E	5-1/2	4-1/2
21 - 50	F	8-1/2	7-1/2
51 - 80	G	11-1/2	10-1/2

Union Connector – For use with remote units for mounting of bulb in fluid being controlled. Available in 1/2" NPT and 3/4" NPT process connections in brass or 316 SS.



Material	Pressure Rating (psig)	Process Connection	
		1/2" NPT Catalog No.	3/4" NPT Catalog No.
Brass	500	QP01	QP02
316 SS	1500	QP05	---

① Jam nuts provided with thermal wells.

Definitions and Fluid Compatibility Guide

Definitions

Accuracy – The maximum deviation from the set point under specified operating condition (ambient temperature, barometric pressure, etc.).

Adjustable Deadband – Refers to the capability of a pressure or temperature switch to allow the deadband to be adjusted over a given range. Certain ASCO TRI-POINT switches have an adjustable deadband which can be adjusted over the total operating range of the switch.

Adjustable Operating Range – The pressure or temperature range of the switch within which the set point may be adjusted.

Differential Pressure – The difference between two pressures. A differential pressure switch senses two pressure sources and can be adjusted to actuate on a desired difference between them.

Gauge Pressure – The actual reading of a typical pressure gauge and is the difference between the pressure within a vessel and the atmospheric pressure surrounding it. It is normally measured in pounds per square inch (psig).

Manual Reset – The switch is a semi-automatic device which operates automatically with a signal change in one direction but must be manually reset once the signal returns to its original position.

Proof Pressure – A pressure which a device can be subjected to for extended periods of time without changes in its operating characteristics.

Rated Overrange Temperature – A temperature which a device can be subjected to for extended periods of time without changes in its operating characteristics.

Repeatability – The closeness of agreement among a number of consecutive measurements of the output for the same value of input under the same operating conditions approaching from the same direction. Repeatability is normally specified as a percentage of the upper limit of the operating range.

Example: Operating range 5-100 psig with $\pm 1\%$ repeatability; equals $\pm 1\%$ of 100 psig or ± 1 psig.

Reset Point – After a pressure or temperature switch has reached its set point and operated the electrical switch, it must return to a point called the reset point before the electrical switch can return to its original position.

Set Point – The pressure reading at which the electrical switch element changes contact position (it can be specified either increasing or decreasing).

Switch Unit – ASCO uses the term “switch unit” to describe the electromechanical portion of a pressure or temperature switch. This is used in conjunction with a transducer unit to form a complete pressure or temperature switch.

Transducer Unit – ASCO uses the term “transducer unit” to describe that portion of a pressure or temperature switch to which a pressure or temperature is applied which converts the input signal to another form of energy to operate the switch unit.

Two-Stage (Dual) – ASCO uses the term “two stage” to describe a pressure or temperature switch which is equivalent to two pressure or temperature switches which are independently adjustable. This switch is equivalent to two fixed deadband switches.

Deadbands – The deadband is the difference between the set point and reset point readings. Deadbands are listed in the specification tables at nominal values. They are representative of the deadbands of the units at the middle of the range.

The deadband values for the full range adjustable deadband switches and limited adjustable deadband switches indicate the values through which the deadband may be adjusted.

Generally, as the set point is adjusted through the operating range, the deadband will vary. Normally, it will become narrower as the set point is towards the bottom of the range, and will become wider when the set point is towards the top of the range. The graph shown below indicates representative trends of this type of deadband variation.

Deadbands

1.5 x Catalog Value

Catalog Value

Half Catalog Value

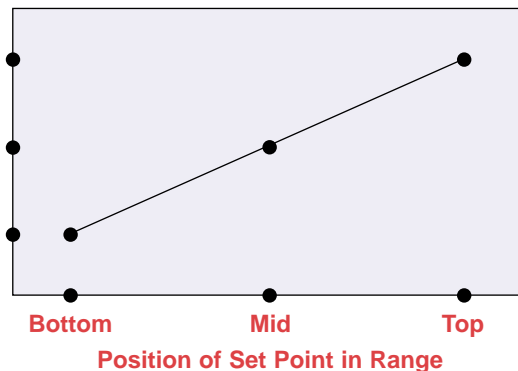

Temperature switch deadbands are a result of the characteristics of the vapor pressure curve as well as other factors. Normally, this results in a deadband which is narrower in the top third of the range than in the bottom third of the range. The values published are nominal and representative of mid-range set points.

Fluid Compatibility Guide

These recommendations are to be used as a guide only, as service life of material is dependent on temperature, concentrations, or catalysts that may be added and other conditions which are beyond our control.

Consult ASCO for specific service applications.

Note: Items in black circles are standard catalog units.
All others available on factory order.

P - Indicates preferred construction. **S** - Indicates satisfactory construction.

Transducer Material Code of Two Digits represents process connection material and diaphragm material, respectively; these are the sixth and seventh positions of the pressure transducer catalog number.

Process Connection: 6th Position Diaphragm: 7th Position

- | | | | |
|------------|---------------|------------|----------------------|
| 1 Aluminum | 4 316 S.S. | 1 Buna "N" | 4 316 S.S. |
| 2 Brass | 7 Nylon/Brass | 2 Viton | 6 Ethylene Propylene |
| 3 303 S.S. | | 3 Neoprene | 7 Fluorosilicone |

Material Code	11	12	13	16	17	21	22	23	26	27	31	32	33	36	37	42	44	71	
	Vacuum	Yes	Yes	Yes	Yes	Yes	Yes	Yes	Yes	Yes	Yes	Yes	Yes	Yes	Yes	Yes	Yes	No	No
	Inches of Water	Yes	Yes	Yes	Yes	Yes	No	No	No	No	No	Yes	Yes	Yes	Yes	Yes	Yes	No	No
P.S.I.G. ⑤ to	400	400	400	400	400	3500	3500	3500	3500	3500	8000	8000	8000	8000	8000	8000	400	200	
Acetic Acid													S	S					P
Acetylene	P	S		S							S	S		S		S	S		
Air	P	S	S	S	S	S	S	S	S	S	S	S	S	S	S	S	S	S	P
Ammonia																			P
Argon-Welding ①	P	S	S	S	S	S	S	S	S	S	S	S	S	S	S	S	S	S	P
Benzene-Benzol		P					S					S				S	S		
Butane	P	S				S	S				S	S				S	S		
Carbon Tetrachloride												P				P	S		
Cellulube		P		S			S		S			S		S		S	S		
Coke Oven Gas												P				P	S		
Ethyl Alcohol (denatured)	P	S	S	S	S	S	S	S	S	S	S	S	S	S	S	S	S	S	
Ethylene Glycol	P	S	S	S		S	S	S	S		S	S	S	S		S	S		
Freon Refrigerants																			P
Freon Solvents ("MF", "TF", "BF")						P	S				S	S				S	S		
Fuel Oils and Diesel ④	P	S				S	S				S	S				S	S		
Gasoline																			P
Gas, Inert	P	S	S	S	S	S	S	S	S	S	S	S	S	S	S	S	S	S	P
Gas (natural and manufactured) ④	P	S	S		S	S	S	S		S	S	S	S		S	S	S		
Helium	P	S	S	S	S	S	S	S	S	S	S	S	S	S	S	S	S	S	P
Hydrogen	P	S	S	S		S	S	S	S		S	S	S	S		S	S		
Jet Fuel (JP1 to JP6)		P			S		S			S		S			S	S	S		
Kerosene	P	S				S	S				S	S							
Methyl Alcohol (Methanol)	P		S	S	S	S		S	S	S	S	S	S	S	S	S	S		
Naphtha	P	S				S	S				S	S				S	S		
Nitrogen	P	S	S	S	S	S	S	S	S	S	S	S	S	S	S	S	S	S	P
Oils (coolant, hydraulic, lubricating and motor)	P	S				S	S				S	S				S	S		P
Oxygen, Gaseous ②		S	P		S		S	S		S		S	S		S	S	S		
Potassium Sulfate	P	S	S	S	S	S	S	S	S	S	S	S	S	S	S	S	S		
Propane Gas and Liquid	P	S	S			S	S	S			S	S	S			S	S		
"Pydraul" ("Monsanto")		P			S		S			S		S			S	S	S		
Steam ③						P	S		S	S	S	S		S	S	S	S		
Steam Condensate						P	S		S	S	S	S		S	S	S	S		P
Stoddard Solvent	P	S				S	S				S	S				S	S		
Toluene (Tolulo)		P					S					S				S	S		
Vacuum	P	S	S	S	S	S	S	S	S	S	S	S	S	S	S	S	S		
Vegetable Oil	P	S	S		S						S	S	S		S	S	S		
Vinegar												S		S	S	S	P		
Water, Fresh, Boiler Feed						P	S		S	S	S	S		S	S	S	S		P
Water (Distilled, Deionized, Demineralized)											P	S	S	S	S	S	S		
Water, Sea																			S

Notes: ① For high purity applications use stainless steel transducers. ② Oxygen service requires special cleaning, specify suffix "H". ③ For steam service a condensate loop (pigtail) is required. ④ For pressure transducers for combustion service see pages 20-23. ⑤ Material availability refers to standard gauge pressure constructions only.

P-SERIES Temperature Switches

Switches for -30 through 510°F with Adjustable Set Points and Fixed or Adjustable Deadband

Features:

- Set point repeatability, $\pm 1^\circ\text{F}$ ($1/2^\circ\text{C}$).
- All wiring terminals, adjustments and visual scales are accessible from the front of the switch.
- Choice of open frame type, general purpose, or watertight enclosure.
- Choice of fixed, limited adjustable or full-range adjustable deadband.
- Choice of single or two-stage units.
- Compact size.
- Mounts in any position.
- Rugged and vibration resistant.
- Visual adjustment scales in $^\circ\text{F}$ and $^\circ\text{C}$.
- Direct mount (local) or capillary and bulb (remote) sensors.
- Temperature transducers available with copper or 316 SS wetted material.
- Withstands high overrange temperatures.
- Mix and match switch and transducer components for increased stock flexibility or to change pressure ranges in field.

General Description:

ASCO P-Series temperature switches consist of an open frame or enclosure protected switch unit and a transducer unit. They can be ordered separately for customer stocking and/or field assembly or as a complete factory-assembled unit.

Switch

P-Series temperature switch units incorporate the unique ASCO TRI-POINT alternating fulcrum balance plate to control the operation of one or more electrical snap-action switches. The electrical snap-action switch together with the adjusting mechanism is a fully-tested, self-contained subassembly.

Transducer

The temperature transducer unit uses a vapor pressure principle where the internal pressure within the unit is generated by the vapor pressure of a chemical within a sealed system. Temperature transducers are available in two constructions, a direct mount or capillary and bulb construction. The direct mount unit includes a 1/2" NPT connection for direct mounting to the process. The capillary and bulb construction allows remote mounting from the process. The transducer unit (like the switch unit) is a fully-tested, self-contained subassembly.



Standard Electrical Ratings

PA, PB, PC [Ⓢ] Series

- 15 Amp Res., 125 VAC
- 10 Amp Res., 250 VAC
- 1/8 HP, 125 VAC
- 1/4 HP, 250 VAC
- 1/2 Amp Res., 125 VDC
- 1/4 Amp Res., 250 VDC

PG [Ⓢ] Series

- 15 Amp Res., 125 VAC
- 10 Amp Res., 250 VAC
- 1/8 HP, 125 VAC
- 1/4 HP, 250 VAC

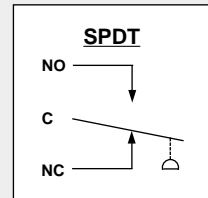

[Ⓢ] PC and PG Series not UL listed or CSA approved, PC Series rated 10 Amp Res., 125/250 VAC; 1/3 HP 125/250 VAC.

Standard Temperature Ratings

Ambient: -4°F (-20°C) to 122°F (50°C)

Fluid: See specification table on page 26 for rated overrange temperature.

Operation

Temperature sensed by the bulb creates an internal pressure within the transducer. This pressure is then converted into movement of the piston. This piston movement is then used to control the operation of the electrical snap-action switch in the switch unit.

Options (See pages 34-35)

Enclosures

ASCO TRI-POINT switches are available in either a general purpose or watertight enclosure, in addition to open frame construction. These enclosed units are made in accordance with NEMA and UL standards. These standards define the protection level an enclosure gives and the tests it must pass to meet a particular design.

General Purpose – Type 1. These enclosures are designed for indoor use to protect personnel from accidental contact with the equipment. P-Series general purpose enclosures are painted, zinc-coated

steel and have a 7/8" diameter hole at the top for electrical entry.

Watertight – Type 4. Watertight and dust-tight enclosures are intended for use indoors and outdoors to protect the enclosed equipment against splashing or falling water, windblown dust and water, hose directed water, and severe external condensation. P-Series watertight switch enclosures are epoxy-painted, zinc-coated steel with a 1/2" conduit hub in the side of the lower housing for electrical entry. (For optional 316 SS watertight enclosure see page 29.)

Dimensions (inches)

P-Series Temperature (Mounting brackets optional)

Open Frame PA and PC Switch Units with Transducer Unit Types RD-RV

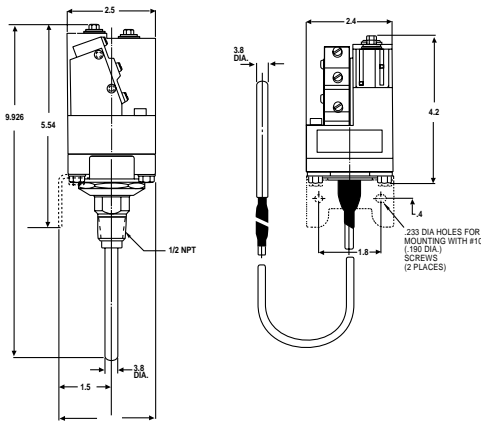

Open Frame PB and PG Switch Units with Transducer Unit

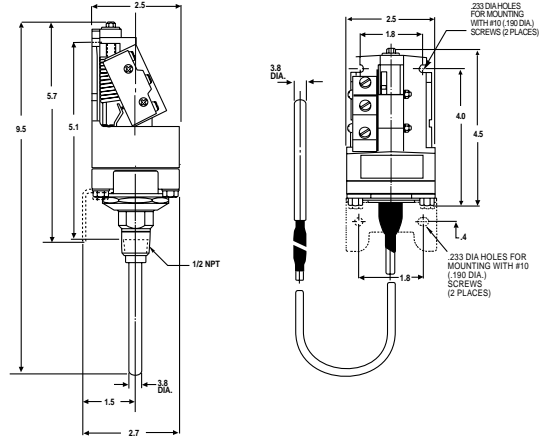

Type 1 General Purpose Switch Unit with Transducer Unit

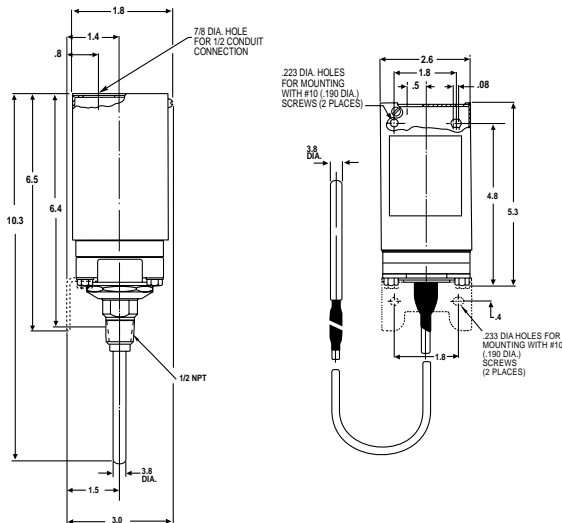

Type 4 Watertight Switch Unit with Transducer Unit

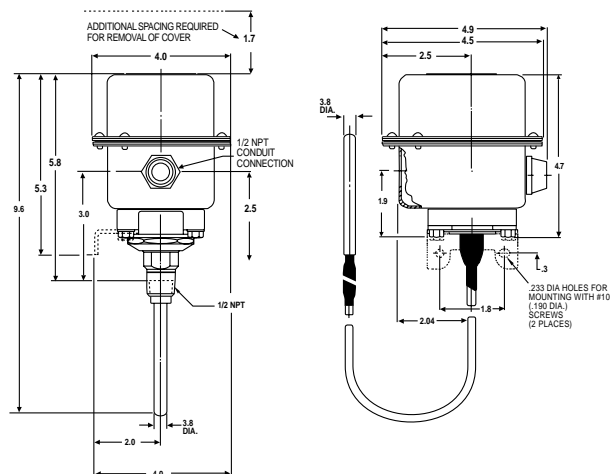

P-SERIES Temperature Switches



General Purpose Enclosure



Watertight Enclosure

How to Select and Order

ASCO P-Series switches consist of two components, the switch unit and the transducer unit.

How to Select

1. Select the adjustable operating range based on desired actuation temperature.
2. Check that rated overrange temperature is sufficient.
3. Read across and select the desired P-Series switch unit with the proper enclosure.
4. Continue across and select a matching transducer unit.

Select P-Series temperature switch

PA Switch Unit

Single-Stage Adjustable Deadband units allow independent adjustment of the set and reset points over the full operating range of the switch. The minimum difference between set and reset points is the deadband listed below; the maximum difference is the full range of the switch.



Open Frame

PB Switch Unit

Single-Stage Fixed Deadband units have an adjustable set point and a non-adjustable automatic reset point.

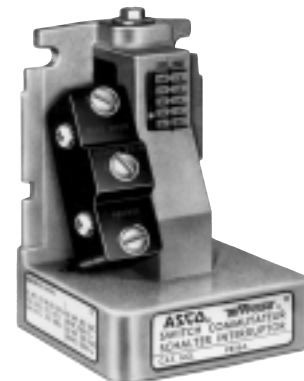

Open Frame

Specifications				Adjustable Deadband			Fixed Deadband				
Adjustable Operating Range (°F)	Rated Overage Temperature (°F)			Adjustable Deadband Maximum Full Scale	Open Frame Catalog No.	General Purpose Catalog No.	Watertight Enclosure Catalog No.	Fixed Deadband At Mid-Range (°F) ①	Open Frame Catalog No.	General Purpose Catalog No.	Watertight Enclosure Catalog No.
	Direct Mount	Capillary									
		Copper	SS	Minimum At Mid-Range (°F) ①							
-30 - 60	250	250	250	10	PA16A	PA10A	PA11B	4	PB16A	PB10A	PB11B
0 - 90	260	300	300	10	PA16A	PA10A	PA11B	4	PB16A	PB10A	PB11B
50 - 160	260	350	350	10	PA16A	PA10A	PA11B	4	PB16A	PB10A	PB11B
100 - 220	260	400	450	10	PA16A	PA10A	PA11B	4	PB16A	PB10A	PB11B
160 - 260	260	500	500	10	PA16A	PA10A	PA11B	4	PB16A	PB10A	PB11B
225 - 340	---	550	600	10	PA16A	PA10A	PA11B	4	PB16A	PB10A	PB11B
300 - 450	---	550	700	12	PA16A	PA10A	PA11B	5	PB16A	PB10A	PB11B
350 - 510	---	550	800	12	PA16A	PA10A	PA11B	5	PB16A	PB10A	PB11B

°C = (°F - 32) x 5/9

All switch units above are in stock for immediate delivery.

① Values shown are nominal.

How to Order

Factory assembled – Simply order the switch and transducer unit by catalog number joined by a slash (/), e.g., PA16A/KA10A1.

Field assembled – Simply order the switch and transducer units separately by individual catalog number, e.g., one PA16A and one KA10A1.

Options – Add appropriate suffix for desired option or accessory (see pages 34-35).

Important Note: The third digit of each of the catalog numbers must be identical, e.g., PA 16A and KA 10A1.

PA, PB, or PC unit below

PC Switch Unit

Two-Stage Fixed Deadband units consist of two separate snap-action switches, each with an independently adjustable set point and non-adjustable reset point. The difference between the set and reset points of each switch is the deadband listed below; the minimum difference between the set points of the two switches is the separation.



Open Frame

Two-Stage Fixed Deadband

Fixed Deadband At Mid-Range (°F)	Separation	Open Frame	General Purpose	Watertight Enclosure				
					Maximum Full Scale	Catalog No.	Catalog No.	Catalog No.
					Minimum At Mid-Range (°F)			
7	9	PC16A	PC10A	PC11B				
7	9	PC16A	PC10A	PC11B				
7	11	PC16A	PC10A	PC11B				
7	12	PC16A	PC10A	PC11B				
7	10	PC16A	PC10A	PC11B				
7	12	PC16A	PC10A	PC11B				
9	15	PC16A	PC10A	PC11B				
9	16	PC16A	PC10A	PC11B				

Select transducer unit below



Direct Mount
1/2" NPT



Capillary
and Bulb

Transducer Unit

The **temperature transducer** works on the vapor principle where the internal pressure within the system is generated by the vapor pressure of a chemical within a sealed system. The temperature sensed by the bulb is related uniquely to an internal pressure within the system. The pressure acts on a diaphragm/piston to create the force output from the transducer into the switch unit. Temperature transducers are available in two constructions. The direct mount (local) unit includes a 1/2" NPT connection for direct application to the process. The capillary and bulb-type construction allows for remote mounting from the process.

Temperature Transducer Units

Direct Mount		6' Capillary and Bulb		12' Capillary and Bulb	
Copper	316 SS	Copper	316 SS	Copper	316 SS
Catalog No.	Catalog No.	Catalog No.	Catalog No.	Catalog No.	Catalog No.
KB10A1	KB10A4	KB11A1	KB11A4	KB11A1D	KB11A4D
KD10A1	KD10A4	KD11A1	KD11A4	KD11A1D	KD11A4D
KF10A1	KF10A4	KF11A1	KF11A4	KF11A1D	KF11A4D
KJ10A1	KJ10A4	KJ11A1	KJ11A4	KJ11A1D	KJ11A4D
KL10A1	KL10A4	KL11A1	KL11A4	KL11A1D	KL11A4D
---	---	KN11A1	KN11A4	KN11A1D	KN11A4D
---	---	KT11A1	KT11A4	KT11A1D	KT11A4D
---	---	KU11A1	KU11A4	KU11A1D	KU11A4D

All switch units and transducer units above are in stock for immediate delivery.

P-SERIES Temperature Switches

How to Select and Order

ASCO P-Series switches consist of two components, the switch unit and the transducer unit.

How to Select

1. Select the adjustable operating range based on desired actuation temperature.
2. Check that rated overrange temperature is sufficient.
3. Read across and select the desired P-Series switch unit with the proper enclosure.
4. Continue across and select a matching transducer unit.

How to Order

Factory assembled – Simply order the switch and transducer unit by catalog number joined by a slash (/), e.g., PG16A/KA10A1.

Field assembled – Simply order the switch and transducer units separately by individual catalog number, e.g., one PG16A and one KA10A1.

Options – Add appropriate suffix for desired option (see pages 34-35).

Important Note: The third digit of each of the catalog numbers must be identical, e.g., PG 1 6A and KA 1 0A1.

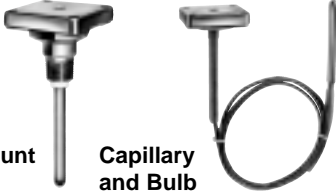
Select P-Series switch unit and transducer unit below													
PG Switch Unit				Transducer Unit									
<p>Limited Adjustable Deadband units have an adjustable set point and use a special snap-action switch that varies the deadband within the limits listed below.</p>  <p>Open Frame</p>				<p>The temperature transducer works on the vapor principle where the internal pressure within the system is generated by the vapor pressure of a chemical within a sealed system. The temperature sensed by the bulb is related uniquely to an internal pressure within the system. The pressure acts on a diaphragm/piston to create the force output from the transducer into the switch unit.</p>  <p>Direct Mount 1/2" NPT Capillary and Bulb</p>									
Specifications				Limited Adjustable Deadband			Temperature Transducer Units						
Adjustable Operating Range (°F)	Rated Overage Temperature (°F)			Adjustable Deadband	Open Frame	General Purpose	Watertight Enclosure	Direct Mount		6' Capillary and Bulb		12' Capillary and Bulb	
	Direct Mount	Capillary						Maximum Full Scale	Copper	316 SS	Copper	316 SS	Copper
		Copper	SS	Minimum At Mid-Range (°F) ①	Catalog No.	Catalog No.	Catalog No.						
-30 - 60	250	250	250	6 - 12	PG16A	PG10A	PG11B	KB10A1	KB10A4	KB11A1	KB11A4	KB11A1D	KB11A4D
0 - 90	260	300	300	6 - 12	PG16A	PG10A	PG11B	KD10A1	KD10A4	KD11A1	KD11A4	KD11A1D	KD11A4D
50 - 160	260	350	350	6 - 12	PG16A	PG10A	PG11B	KF10A1	KF10A4	KF11A1	KF11A4	KF11A1D	KF11A4D
100 - 220	260	400	450	6 - 12	PG16A	PG10A	PG11B	KJ10A1	KJ10A4	KJ11A1	KJ11A4	KJ11A1D	KJ11A4D
160 - 260	260	500	500	6 - 12	PG16A	PG10A	PG11B	KL10A1	KL10A4	KL11A1	KL11A4	KL11A1D	KL11A4D
225 - 340	---	550	600	6 - 12	PG16A	PG10A	PG11B	---	---	KN11A1	KN11A4	KN11A1D	KN11A4D
300 - 450	---	550	700	6 - 12	PG16A	PG10A	PG11B	---	---	KT11A1	KT11A4	KT11A1D	KT11A4D
350 - 510	---	550	800	6 - 12	PG16A	PG10A	PG11B	---	---	KU11A1	KU11A4	KU11A1D	KU11A4D

°C = (°F - 32) x 5/9

All switch units and transducer units above are in stock for immediate delivery.

① Values shown are nominal.

Switches with Optional 316 Stainless Steel Enclosure

Every ASCO P-Series temperature switch is available in a corrosion-resistant, stainless steel enclosure. Typical applications include:

- Offshore platforms
- Hydrocarbon processing plants
- Oil & gas fields
- Oil & gas transmission lines
- Chemical plants
- Breweries
- Paper pulp mills
- Salt spray locations

Stainless Steel Enclosure

ASCO Type 4X watertight enclosure is designed to provide protection against windblown dust, rain, sleet or external ice formation. The switch and transducer unit are available only as factory-assembled units.

How to Select and Order

ASCO P-Series switches with 316 SS enclosure consist of two factory-assembled components, the switch unit and the transducer unit.

How to Select (use tables on pages 26-28)

1. Select the adjustable operating range based on desired actuation temperature.
2. Check that rated overrange temperature is sufficient.
3. Read across and select the desired P-Series switch unit with open frame construction.
4. To add a 316 SS enclosure, change the fourth digit of the open frame catalog number from "6" to "5", e.g., PG1 [6]A becomes PG5 [5]A.
5. Continue across and select a matching direct mount or capillary and bulb transducer unit compatible with the fluid. For direct mount unit add suffix "D" to switch catalog number, e.g., PG15A becomes PG15AD; for capillary and bulb unit add suffix "C", e.g., PG15A becomes PG15AC.

How to Order

Factory assembled only – Simply order the switch and transducer unit by catalog number joined by a slash (/), e.g., PG15AD/KA10A4 for direct mount and PG15AC/KA11A4 for capillary and bulb unit.

Options – Add appropriate suffix for desired option (see pages 34-35).



Dimensions (inches)

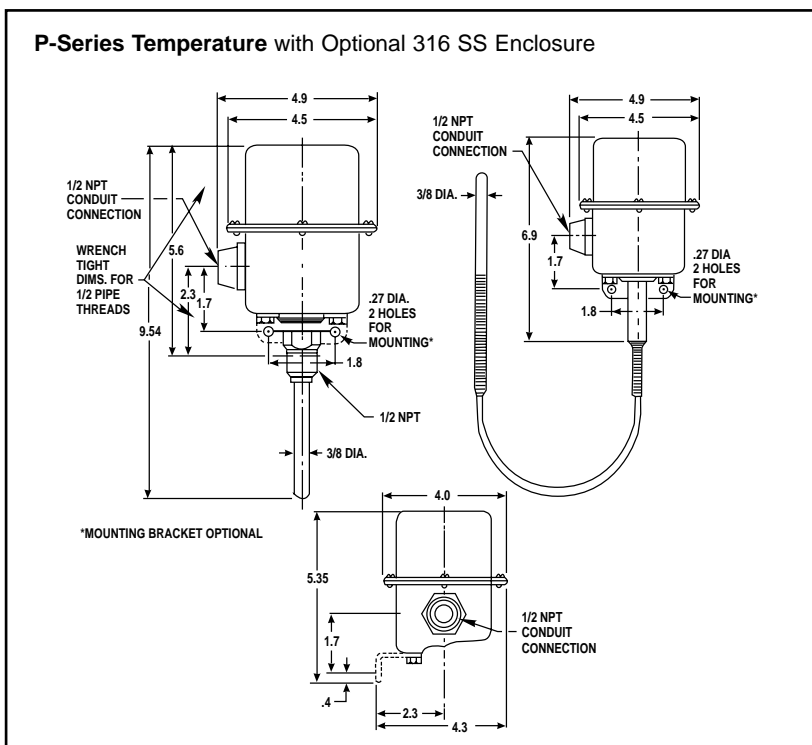

OPTIONS Pressure/Temperature Switches

H-Series, P-Series and S-Series Snap-Action Switch Options

Optional snap-action switches to meet specific electrical loads or application conditions are available on most ASCO TRI-POINT switch units. Generally, the construction of a switch unit with optional snap-action switches contains other specific parts and may be ordered only as a factory-built unit. To specify a particular optional construction, add the appropriate suffix to the switch unit catalog number, e.g., SA10D with optional gold contact snap-action switch (suffix "P") would become SA10D[P].

P-Series Switch Options

Panel Mount – Open frame P-Series compact switch units are available for panel mounting with the switch unit inside and the transducer outside. The panel separates the fluid sensing portion from the electromechanical portion. Five holes for bolts and operating stem must be drilled or punched through the panel. Three constructions are available: add the suffix listed below to the switch unit catalog number for the desired thickness.

Description	Electrical Rating	Catalog Suffix	Deadband Variation From Listing
DC Rating 1 Amp Double Break	5 Amp, 125, 250 VAC 1/4 HP, 125 VAC 1/2 HP, 250 VAC 1 Amp, 125 VDC 1/2 Amp, 250 VDC	G	SA: +50% SB, SC, PA: +100% H: +200% PB: +400%
DC Rating 10 Amps, SPDT	10 Amp, 125 VAC, VDC 1/8 HP, 125 VAC, VDC	M	SA: +50% SB, SC, PA: +100% H: +120% PB: +400%
Double-pole Double-throw (Two SPDT Switches with Common Lever) Gold Contact Dry Circuit SPDT	5 Amp, 125, 250 VAC 1/8 HP, 125 VAC 1/4 HP, 250 VAC 1/2 Amp, 125 VDC 1/4 Amp, 250 VDC 1 Amp, 28 VAC 1 Amp, 28 VDC	K P	SA, SB, SD, SE, PB: +50% SA, SB, SC, PA: +25% H: +50% PB, PC: +100%
Hermetically Sealed SPDT	25 Amp Res, 28 VDC 10 Amp Ind, 28 VDC 5 Amp Motor, 28 VDC 3 Amp Lamp, 28 VDC 1 Amp, 125 VAC	H	SA, PA: +100% H: +200% PB: +600%
High Ambient 250°F SPDT	5 Amp, 125, 250 VAC 1/8 HP, 125 VAC 1/4 HP, 250 VAC 1/2 Amp, 125 VDC 1/4 Amp, 250 VDC	F	SA, SB, SC: +25%
High Power 1 HP SPDT	20 Amp, 125, 250 VAC 1 HP, 125 VAC 2 HP, 250 VAC 1/2 Amp, 125 VDC 1/4 Amp, 250 VDC	W	SA: +50% SB, SC: +100% PB: +400%
Moisture Resistant Sealed Switch SPDT	5 Amp, 125, 250 VAC 1/8 HP, 125 VAC 1/4 HP, 250 VAC 1/2 Amp, 125 VDC 1/4 Amp, 250 VDC	J	SA: None SB, SC, PA: +25% PB, H: +50%
Tight Fixed Deadband SPDT	5 Amp, 125, 250 VAC 1/8 HP, 125 VAC 1/4 HP, 250 VAC 1/2 Amp, 125 VDC	T	SB, SC: -50%

Panel Thickness	Suffix
10 Ga (.135±.005)	10
14 Ga (.075±.005)	11
16 Ga (.060±.005)	12

S-Series Switch Options

Industrial Adjusting Nut Covers – Available in clear plastic or metal to prevent tampering with set point adjusting nuts.

Clear plastic cover: To order, add suffix "1" to the switch unit catalog number, or order separately as SP01.
Metal cover: To order, add suffix "2" to the switch unit catalog number, or order separately as SP02.

JIC Construction – A switch unit having the electrical and adjusting nut covers attached to the switch body by a chain. Also designed to Type 13 specifications. To order, add suffix "3" to the switch unit catalog number, or order separately as SP03.

Terminal Block – Applicable to switch units with one single-pole double-throw switch. The terminal strip is prewired to the snap-action switch. To order, add suffix "4" to the switch unit catalog number, or order separately as SP04.

Factory Sealed – Explosion-proof units may be ordered with a factory seal separating the electrical chamber from the conduit hubs and 24" long #14 AWG 105°C. rated lead wires. To order, change the fourth digit of the switch unit catalog number from "2" to "3", e.g., SA1[2]D becomes SA1[3]D.

Pressure Transducer Options

Special Wetted Materials – The following diaphragms may be substituted on transducer body materials of aluminum, brass, polyester and stainless steel. To order, substitute the material code below in the seventh digit of the transducer catalog number, e.g., a TF10A1 [1] with optional viton diaphragm becomes a TF10A1 [2].

Diaphragm	Material Code	Temperature Range
Buna "N"	1	-4°F (-20°C) to 180°F (82°C)
Ethylene Propylene	6	-4°F (-20°C) to 250°F (121°C)
Neoprene	3	-4°F (-20°C) to 180°F (82°C)
Fluorosilicone	7	-40°F (-40°C) to 250°F (121°C)
Viton	2	-4°F (-20°C) to 250°F (121°C)

Oxygen Cleaning – Pressure transducers for oxygen service should be specially cleaned. They are degreased and blacklight inspected, then assembled in a clean area and tested with oil-free air or nitrogen. Use metal body transducer with viton or neoprene diaphragm and add suffix "H" to transducer catalog number, e.g., TA40A13 becomes TA40A13 [H].

Pressure Snubbers – A pressure snubber (1/4" NPTF by 1/4" NPTM) installed in the transducer pressure connection will dampen the pressure spikes to a value which will not cause damage. It consists of a body with a porous metal disc of stainless steel through which the fluid passes. To order, select a snubber compatible with the fluid. Available by separate catalog number only (see table below).

Fluid	Brass Catalog No.	303 SS Catalog No.
Air, Non-Hazardous Gases	TP04G2	TP04G3
Water, Light Oil (under 225 SSU)	TP04E2	TP04E3
Oil (Heavy, (over 225 SSU)	TP04D2	TP04D3
Pressure Rating (psig)	2000	5000

Process Connection – A female process connection (1/4" NPT) is standard on all pressure transducers. A 1/2" NPT is available as an option on *gauge* pressure transducers. To order, add suffix "B" to transducer catalog number, e.g., RF10A21 becomes RF10A21 [B].

Note: Not available on nylon transducers.

P-Series and S-Series Temperature Transducer Options

Armored Capillaries – Double braided copper armor is standard for copper capillary units. Stainless steel spiral interlocked armor is available for stainless steel capillary units. Add suffix "C" to transducer catalog number.

Thermal Well



Thermal Well ① – Use with direct or remote sensors for protecting sensing bulb. This allows removal of bulb while maintaining a pressure-tight vessel. Available in 1/2" NPT or 3/4" NPT process connection in brass or 316 SS. Dimensions are in accordance with SAMA Std. RC17-9. Standard "U" dimension (insertion length) is 2-1/2" for direct mount and 6' capillary units and is 4-1/2" for 12' capillary units.

Material	Pressure Rating (psig)	"U" Dimensions (Inches)	Process Connection	
			1/2" NPT Catalog No.	3/4" NPT Catalog No.
Brass	1000	2-1/2	QP03	QP04
		4-1/2	QP13	QP14
		7-1/2	QP23	QP24
		10-1/2	QP33	QP34
316 SS	6000	2-1/2	QP07	QP08
		4-1/2	QP17	QP18
		7-1/2	QP27	QP28
		10-1/2	QP37	QP38

Longer Capillaries – Standard copper and stainless steel capillary units can be furnished in 12' lengths. To order, add suffix "D" to transducer catalog number.

Consult ASCO for longer length capillaries.

Capillary Length (Feet)	Transducer Suffix	Bulb Length (Inches)	"U" Dimension Required (Inches)
6	---	3-1/2	2-1/2
12	D	5-1/2	4-1/2
13 - 20	E	5-1/2	4-1/2
21 - 50	F	8-1/2	7-1/2
51 - 80	G	11-1/2	10-1/2

Union Connector – For use with remote units for mounting of bulb in fluid being controlled. Available in 1/2" NPT and 3/4" NPT process connections in brass or 316 SS.



Material	Pressure Rating (psig)	Process Connection	
		1/2" NPT Catalog No.	3/4" NPT Catalog No.
Brass	500	QP01	QP02
316 SS	1500	QP05	---

① Jam nuts provided with thermal wells.