

HI 1769-WS & HI 1769-2WS WEIGH SCALE MODULE

OPERATION AND INSTALLATION MANUAL

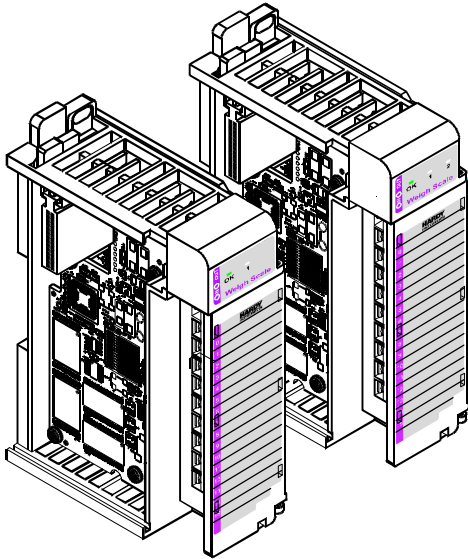

Corporate Headquarters

9440 Carroll Park Drive

San Diego, CA 92121

Phone: (858) 278-2900

FAX: (858) 278-6700

Web-Site: <http://www.hardysolutions.com>



Hardy Process Solutions Document Number: 0596-0282-01 Rev T

Copyright 2011-2013 Hardy Process Solutions, All Rights Reserved. Printed in the U.S.A. (941028)

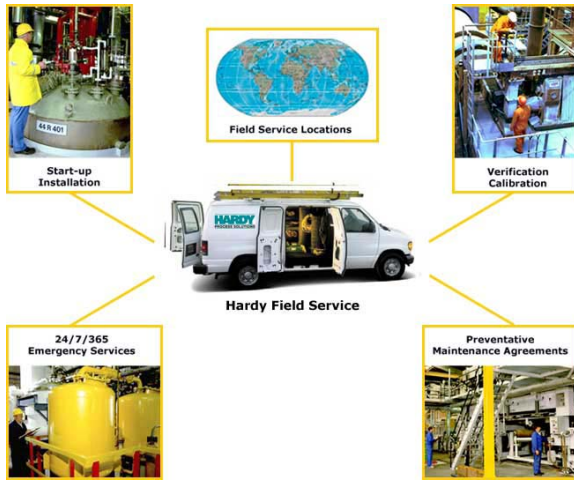

Local Field Service

Hardy has over 200 field technicians in the U.S., and more positioned throughout the world to assist you in your support needs. We also have factory engineers who will travel to your facility anywhere in the world to help you solve challenging applications. We're ready to support you with:

- **Installation and start-up**
- **Routine maintenance and certification**
- **Plant audits and performance measurement**
- **Emergency troubleshooting and repair**

To request Emergency Service and Troubleshooting, Start-up, Installation, Calibration, Verification or to discuss a Maintenance Agreement please call **800-821-5831 Option 4** or Emergency Service after hours (Standard Hours 6:00 AM to 5:30 PM Pacific Standard Time) and weekends.

Outside the U.S

Hardy Process Solutions has built a network of support throughout the globe. For specific field service options available in your area please contact your local sales agent or our U.S. factory at +1 **858-292-2710, Option 4**

OK Module Status LED - - - - -	-4-2
Setting Up Communications Between the MicroLogix 1500 Processor and the HI 1769-WS & HI 1769-2WS Weigh Scale Modules - - - - -	-4-3
Alternative Setup Procedures - - - - -	-4-5
Configuring the HI 1769-WS in RSLogix 500 for MicroLogix 1500 - - - - -	-4-5
Configuring the HI 1769-WS in RSLogix 5000 for CompactLogix-4-7	
Parameters for the HI 1769-WS Module- - - - -	-4-10
About Parameters - - - - -	-4-10
Configuration Parameters for the HI 1769-WS Module- - - - -	-4-12
Commands - - - - -	-4-15
About Commands - - - - -	-4-15
Command Operation - - - - -	-4-16
Possible COMMAND STATUS Values - - - - -	-4-16
Command Table - - - - -	-4-17
Calibration Setup Procedures - - - - -	-4-24
Setting the Metric Parameter - - - - -	-4-24
Setting the Motion Tolerance Value - - - - -	-4-24
Setting The Zero Tolerance Value- - - - -	-4-25
Setting the Auto Zero Tolerance Value - - - - -	-4-25
Setting the Number of Readings Averages - - - - -	-4-25
Setting the Span Weight Value - - - - -	-4-25
Setting the WAVERSAVER Value- - - - -	-4-25
 CHAPTER 5 - CALIBRATION5-1	
A Brief Description of Chapter 5- - - - -	-5-1
Pre-Calibration Procedures - - - - -	-5-1
Electrical Check Procedures - - - - -	-5-2
Load Cell/Point Input/Output Measurements- - - - -	-5-2
Load Check - - - - -	-5-4
C2 Calibration - - - - -	-5-5
About C2 Calibration - - - - -	-5-5
C2 Calibration Using Ladder Logic - - - - -	-5-5
Hard Calibration - - - - -	-5-6
Hard Calibration Ladder Logic Example - - - - -	-5-6
 CHAPTER 6 - TROUBLESHOOTING- - - - -	-6-1
A Brief Description of Chapter 6- - - - -	-6-1
Scale LED is Flashing Red - - - - -	-6-1
Mechanical Inspection - - - - -	-6-1
Load Sharing and Load Sensor Checkout - - - - -	-6-3
Guidelines for Instabilities on Formerly Operating Systems - - - - -	-6-5

HI 1769-WS/HI 1769-2WS WEIGH SCALE MODULE

Electrical - - - - -6-6
Mechanical Stability and Configuration Settings - - - - -6-7

INDEX

Table of Illustrations

HI 1769-WS & HI 1769-2WS1-1

WEIGH SCALE MODULE1-1

TABLE OF CONTENTS1-I

TABLE OF ILLUSTRATIONS1-I

OVERVIEW1-1

CHAPTER 2 - SPECIFICATIONS2-1

CHAPTER 3 - INSTALLATION3-1

POSITIONING THE MODULE FOR INSTALLATION3-3

CONNECTOR UNLOCK POSITION3-3

CONNECTOR IN LOCKED POSITION3-4

MODULE CONNECTOR INSTALLED3-6

MODULE CONNECTOR REMOVED FOR EASIER CABLING3-7

RAIL FASTENERS IN RETRACTED POSITION3-8

RAIL FASTENERS IN THE CLOSED POSITION3-9

INDUSTRY STANDARD LOAD CELLS WIRING DIAGRAM3-10

HARDY LOAD SENSOR/C2 WIRING DIAGRAM3-11

REMOTE TERMINAL ASSEMBLY3-12

RTA DIN RAIL MOUNT3-12

RTA CABLE ASSEMBLY - HI 1769-WS3-13

RTA CABLE SCHEMATIC - HI 1769-WS3-13

RTA CABLE - HI 1769-2WS3-13

RTA SCHEMATIC HI 1769-2WS3-14

EMI SUPPRESSION CORE3-15

SUPPRESSION CORE OPEN3-15

SUPPRESSION CORE INSTALLED3-16

HARDY HI 215IT JUNCTION BOX WIRING DIAGRAM3-16

CHAPTER 4 - SETUP4-1

MODULE LEDS HI 1769-WS SINGLE CHANNEL4-1

MODULE LEDS HI 1769-2WS DUAL CHANNEL4-2

I/O CONFIGURATION DIALOG BOX4-3

READ I/O CONFIGURATION FROM ONLINE PROCESSOR DIALOG BOX4-4

CONNECTION/CONFIGURATION - 484-5

EXPANDING CONTROLLER4-6

HI 1769-WS/HI 1769-2WS WEIGH SCALE MODULE

I/O CONFIGURATION DIALOG BOX4-6
I/O CONFIGURATION DIALOG BOX4-7
SELECTING COMPACTBUS LOCAL4-8
SELECT MODULE TYPE/SELECTING 1769 MODULE/GENERIC4-8
MODULE PROPERTIES DIALOG BOX/CONFIGURATION/SIZE/0 WORDS4-9
MODULE PROPERTIES DIALOG BOX/CONFIGURATION/SIZE/48
WORD
S4-9
CONTROLLER TAGS/SLOT 14-15

CHAPTER 5 - CALIBRATION5-1

PROPERLY INSTALLED LOAD CELL W/NO BINDING5-2
MILLIVOLTS/WEIGHT SCALE5-4

CHAPTER 6 - TROUBLESHOOTING6-1

MECHANICAL INSPECTION6-2
LOAD SHARING AND LOAD SENSOR CHECKOUT6-4
GUIDELINES FOR INSTABILITIES ON FORMERLY OPERATING SYS-
TEMS6
-5
GUIDELINES FOR INSTABILITIES ON FORMERLY OPERATING SYSTEMS
- ELEC-
TRI-
CAL6-6
MECHANICAL STABILITY AND CONFIGURATION SETTINGS6-7

INDEX1-1

CHAPTER 1 - OVERVIEW

A BRIEF DESCRIPTION OF CHAPTER 1

This manual provides the user and service personnel with a description of the specifications, installation, setup, configuration, operation, communication, maintenance, and troubleshooting procedures for the Hardy HI 1769-WS & HI 1769-2WS Compact and Micro Logix I/O Weigh Scale Modules that mount on the Allen-Bradley® CompactLogix™ and MicroLogix™ 1500 platform. The HI 1769-WS & HI 1769-2WS are equipped with WAVERSAVER®, C2® Calibration, and INTEGRATED TECHNICIAN® (IT) diagnostics. The module is configurable via ladder logic. The HI 1769-WS & HI 1769-2WS modules mechanically lock together by means of a tongue-and-groove design and have an integrated communication bus that is connected from module to module by a moveable bus connector. To get the maximum service life from this product, users should operate this module in accordance with recommended practices either implied or expressed in this manual. Before using the Weigh Scale Module, all users and maintenance personnel should read and understand all cautions, warnings, and safety procedures, either referenced or explicitly stated in this manual, to ensure the safe operation of the module. Hardy Process Solutions appreciates your business. Should you not understand any information in this manual or experience any problems with the product, please contact our Customer Support Department at:

Phone: (858) 278-2900

FAX: (858) 278-6700

e-mail: hardysupport@hardysolutions.com

Web Address: www.hardysolutions.com

NOTE:

WAVERSAVER®, C2®, IT® are registered trademarks of Hardy Process Solutions Inc. Integrated Technician is a trademark of Hardy Process Solutions Inc.

Allen-Bradley®, CompactLogix™ and MicroLogix™ 1500 are trademarks of the Rockwell Corporation.

HI 1769-WS/HI 1769-2WS WEIGH SCALE MODULE

NOTE:

Hardy Process Solutions bases all procedures with the assumption that the user has an adequate understanding of Allen-Bradley ControlLogix®. In addition the user should understand process control and be able to interpret ladder logic instructions necessary to generate the electronic signals that control your application(s).

About Hardy Manuals

Every Hardy Installation and Operation manual is organized into easily referenced chapters, that are almost always the same:

- **Chapter 1** - Provides an introduction to the instrument and an **Overview** of the equipment and its capabilities.
- **Chapter 2** - Provides a complete list of **Specifications**.
- **Chapter 3** - Contains complete instructions needed to install the HI 1769-WS (both standard and optional equipment) and the Remote Termination Assembly (-RTA)
- **Chapter 4** - Provides complete hardware **Configuration** instructions for setting dip switches and jumpers.
- **Chapter 5** - Provides all **Calibration** instructions.
- **Chapter 6** - Pertains to the **Troubleshooting** procedures for repair of the instrument.

Hardy hopes that this manual meets your needs for information and operation. All corrections or suggestions for improvements of this manual are welcome and can be sent to the Technical Publications Department or Customer Support Department at Hardy Process Solutions Inc.

Description

The HI 1769-WS & HI 1769-2WS Weigh Scale Modules are self-contained, microprocessor-based ControlLogix I/O modules with control inputs and outputs, that is designed to be easily plugged into an Allen-Bradley CompactLogix or MicroLogix 1500 programmable controller. The HI 1769-WS Weigh Scale Module is a single channel module while the HI 1769-2WS is configured for dual operation which

can be used for a wide variety of process weighing applications such as batching, blending, filling/dispensing, check weighing, force measurement, level by weight and weight rate monitoring. The analog to digital converter in the weigh module controller updates one hundred (100) times per second and is capable of 8,388,608 counts of display resolution. This gives the instrument the ability to tolerate large “dead” loads, over sizing of load cells/sensors and still have sufficient resolution to provide accurate weight measurement and control. The module calibration is electronic via C2 electronic calibration. C2 or Hard (Traditional calibration with weights) is also available for those not using Hardy C2 certified load sensors.

WAVERSAVER®

Typically, mechanical noise (from machinery in a plant environment) is present in forces larger than the weight forces trying to be detected by the module.

The HI 1769-WS & HI 1769-2WS is fitted with WAVERSAVER® technology which eliminates the effects of vibratory forces present in all industrial weight control and measurement applications. By eliminating the factor of vibratory forces the module is capable of identifying the actual weight data.

WAVERSAVER® can be configured to ignore noise with frequencies as low as 0.25 Hz. One of five higher additional cut off frequencies may be selected to provide a faster instrument response time. The default factory configuration is 1.00 Hz vibration frequency immunity.

C2® Calibration

C2 Second Generation Calibration enables a scale system to be calibrated electronically without using certified test weights which equals the systems load capacity. A C2 weighing system consists of up to eight (8) C2 load sensors, a junction box, interconnect cable and an instrument with C2 capabilities as long as power requirements don't exceed specification. All Hardy C2 certified load sensors contain digital information detailing its unique performance characteristics. The modules read the performance characteristics of each individual load sensor and

detects the quantity of load sensors in the system. All calibrations can be performed via ladder logic.

IT[®]

INTEGRATED TECHNICIAN[™] is a system diagnostics utility. For full functionality the weigh system should include an HI 215IT series junction box. Full **IT** functionality allows the operator to rapidly troubleshoot a weighing system.

Digital Volt Meter (DVM) - Optional

Requires the HI 215IT Series Junction Box to monitor both and mV/V readings for the system and per individual load sensor. Once a problem is detected by the operator the DVM readings help the operator to isolate the faulty component. Further, the DVM readings can be used to level a system and to make corner adjustments to platform scales. Accuracy is +/- 2% or better of full scale.

NOTE:

If you do not have the HI 215IT Junction Box connected to the module, the mV/V reading as displayed is the total for all the load cells on the system.

Rate of Change

The ROC option measures and displays the rate at which a material enters or is dispensed from the scale over a period of time. ROC data uses a 100-entry register. New weight values are written to the register at the rate of 1/100th of the time base. The first register is subtracted from the 101st Register, which is one time base older than the first register. The ROC is reported in units per minute. A time base of discrete values is selectable from 1 to 1800 sec

Return to Zero Test - Optional

Requires the HI 215IT Series Junction Box to monitor individual load sensors. This test compares the original voltage reading (saved at calibration) against the current voltage reading of an empty vessel. The test checks for damaged load sensors due to electrical zero shift or abnormal mechanical forces that cause binding on one or all of the load sensors in the system.

Weighing System Tests - Optional

Requires the HI 215IT Series Junction Box for full utilization. This test is used to diagnose drifting or unstable weight reading problems. The Weighing System Test does the following:

1. Disconnects the controller and engages an internal reference signal to see if the problem is within the instrument.
2. Disconnects the load sensors and engages an internal (in the junction box) reference signal to see if the cable between the instrument and the Junction Box is causing the problem.
3. Reads the weight of each load sensor to see if the load sensor might be causing the problem.

The ability to read the weight seen by each individual load sensor allows use of this test to make cornering, leveling and load sharing adjustments to the weighing system.

AUTO ZERO TRACKING

Auto Zero Tracking indicates zero weight, as long as any “live weight” on the scale is below the set Auto Zero Tolerance, this function is turned on and the scale is not in motion. This capability allows the module to ignore material build-up in the weighing system within a pre-set auto zero tolerance.

HI 1769-WS/HI 1769-2WS WEIGH SCALE MODULE

CHAPTER 2 - SPECIFICATIONS

A Brief Description of Chapter 2

Chapter 2 lists the specifications for the HI 1769-WS & HI 1769-2WS Weigh Scale Modules. Specifications are listed for the standard instrument and for optional equipment. The specifications listed are designed to assist in the installation, operation and troubleshooting of the instrument. All service personnel should be familiar with this section before attempting an installation or repair of this instrument.

Specifications for a Standard HI 1769-WS Weigh Scale Module

Maximum Installed Modules	8 modules - per power supply in a single bank (Module(s) must be installed within 4 slots on either side of the power supply)	
Channels	1 Channel	HI 1769-WS
	2 Channel	HI 1769-2WS
Conversion Rate	100 updates per second	
Averages	1-255 User Selectable in single increments	
Resolution	Internal:	1:8,388,608
Input	Up to four (4) 350 ohm Full Wheatstone Bridge, Strain Gauge Load Sensors/Cells (5 volt excitation) on one vessel.	
Non-Linearity	0.0015% of Full Scale	
WAVERSAVER®	User Selectable	
	<ul style="list-style-type: none">• 4.00 Hz• 2.00 Hz• 1.00 Hz (Default)• 0.50 Hz• 0.25 Hz• OFF	
Common-Mode Rejection	120dB from 59 to 61 Hz	

HI 1769-WS/HI 1769-2WS WEIGH SCALE MODULE

Common-Mode Voltage Range	2.5VDC maximum (with respect to earth ground)
Bus Input Voltage	5 VDC
Bus Current Load	<0.5 Amp at 5 VDC
Bus Power Load	< 5W at 5 VDC
C2 Calibration Input	Isolation from digital section 1000 VDC minimum.
Cable lengths	500 feet maximum of C2 authorized cable 250 feet maximum of C2 authorized cable (Maximum of 4 load sensors) with IT Junction box.
Load Cell Excitation	5 VDC
C2 Calibration Output	Isolation from digital section 1000 VDC minimum

Environmental Requirements

Temperature Coefficient	Less than 0.005% of full scale per degree C for Cal-LO and Cal-HI reference points
Operating Temperature Range	0° C to 60° C (32° F to 140° F)
Storage Temperature Range	-40° C to 85° C (-40° F to 185° F)
Humidity Range	0-95% (non-condensing)
Approvals	CE, UL/CUL, Class I, Division 2 Groups A, B, C, D Temperature Code T5
Digital Voltmeter	Accuracy 10% of full scale Resolution

- mV/V 4 digits to the right of the decimal

Optional Equipment

1756 RTA (Remote Termination Assembly)

Hardy Part # -RTA (HI-1769-XX-RTA if ordered separately) Remote Termination supports two (2) separate HI 1769-WS or HI 1769-2WS weigh scale modules. Unit includes DIN rail mounting for 35mm x 15mm DIN rail.

RTA Cable Assemblies

Hardy Part # -C6 (HI 1769-XX-C6)

- Cable Length: 6 ft. (1.525 meters) from the single channel module to the RTA.

Hardy Part # - D8 (HI 1769-XX-DC6)

- Cable Length: 6 Ft. (1.525 meters) from 2 single or one dual module to the RTA.

HI 215IT Series Junction Box

NEMA rated waterproof enclosure which sums from one to four load sensors load sensors.

- -PS1 NEMA 4 Painted Steel
- -SS1 NEMA 4X Stainless Steel
- -FG1 NEMA 4X Fiberglass

Default Parameters

Parameter	Default	Setting
ChanActive	On	1
Calib Type	none	OXXXXF
Tareweight	0.0 lbs	0
Metric	lbs	0
WAVERSAVER®	1 Hz	3
SpanWeight	10,000.00	10,000.00
CallowWeight	0 lbs	0
Num Averages	10	10
ROC Timebase	10 sec	10

Table 2-1: Default Parameters

HI 1769-WS/HI 1769-2WS WEIGH SCALE MODULE

Parameter	Default	Setting
ZeroTrackEnable	False	0
ZeroTolerance	10.0 lbs	10.0
AutoZeroTolerance	10.0 lbs	10.0
MotionTolerance	5.0 lbs	5.0

Table 2-1: Default Parameters

EMI Suppression Core

Cable Diameter .250 inches Max. (6.4 mm Max)

**Supression
Frequencies** Up to 500 MHz

Cable Types

- Multi-strand
- Single Conductor

**Physical
Dimensions**

Width - .705 inches (17.9 mm)
Height - .724 inches (18.39 mm)
Length - 1.272 inches (32.3 mm)

CHAPTER 3 - INSTALLATION

A Brief Description of Chapter 3

All information contained in Chapter 3 pertains to unpacking, cabling, interconnecting, configuration and installing the Weigh Scale Module. Alternatives to any procedures contained or implied in this chapter are not recommended. It is very important that the user and service personnel be familiar with the procedures contained in this chapter, before installing or operating the Weigh Scale module. Hardy Process Solutions appreciates your business. Should you experience any problems installing this equipment, contact Hardy Customer Support for assistance.

Unpacking

- Step 1. Before signing the packing slip, inspect the packing for damage of any kind.
- Step 2. Report any damage to the carrier company immediately.
- Step 3. Check to see that everything in the package matches the bill of lading. You should normally have:
 - HI 1769-WS or HI 1769-2WS Weigh Scale Module
 - Operation & Installation Manual
- Step 4. Write down the Model and Serial number of the module. Store this information in a convenient location for reference when contacting The Customer Support Department for parts or service.

WARNING

EXPLOSION HAZARD - DO NOT DISCONNECT WHILE CIRCUIT IS ALIVE UNLESS AREA IS KNOWN TO BE NON-HAZARDOUS.

WARNING

EXPLOSION HAZARD - SUBSTITUTION OF COMPONENTS MAY IMPAIR SUITABILITY FOR CLASS I, DIVISION 2.

WARNING

RISK OF FIRE OR EXPLOSION. DO NOT OPERATE SWITCH WHILE CIRCUIT IS LIVE.

HI 1769-WS/HI 1769-2WS WEIGH SCALE MODULE

Installing the
HI 1769-WS or
HI 1769-2WS to an
Allen-Bradley
CompactLogix or
MicroLogix 1500
Processor

WARNING

ELECTROSTATIC DISCHARGE MAY DAMAGE SEMICONDUCTOR COMPONENTS. DO NOT TOUCH THE CONNECTOR PINS AND OBSERVE THE FOLLOWING HANDLING PRECAUTIONS:

- Wear an approved wrist-strap grounding device when handling the module.
- Touch a grounded object or surface to rid yourself of any electrostatic discharge prior to handling the module.
- Handle the module from the bezel in front away from the connector. Never, **NEVER** touch the connector pins.
- Wiring must be in accordance with Class I, Division 2 wiring methods of the National Electrical Code, NFPA 70 and acceptable to the authority having jurisdiction.
- Do not install the module right next to an AC or high voltage DC module.
- Route all the load voltage cables away from high voltage cables.

Installing the
HI 1769-WS or
HI 1769-2WS onto
the CompactLogix
and MicroLogix
1500 Bank

- Step 1. Make sure that the module is oriented correctly for installation. (See Fig. 3-1)

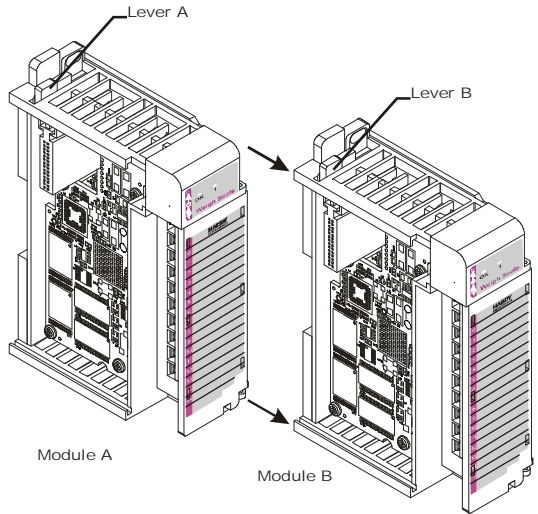

FIG. 3-1 POSITIONING THE MODULE FOR INSTALLATION

Step 2. Pull Lever B back to the unlock position.

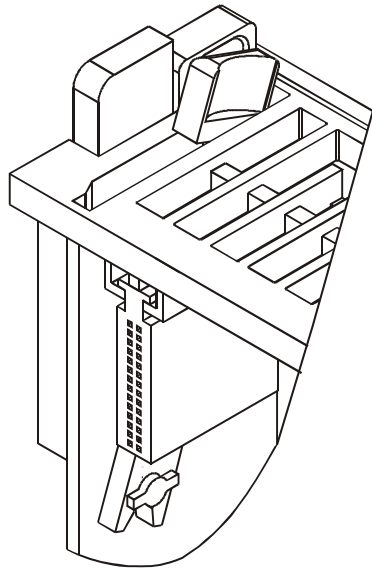

FIG. 3-2 CONNECTOR UNLOCK POSITION

HI 1769-WS/HI 1769-2WS WEIGH SCALE MODULE

- Step 3. Gently slide the HI 1769-WS or HI 1769-2WS module onto the other module. In our example we connected two Hardy HI 1769-WS Weigh Modules.
- Step 4. When you have the modules aligned, press Lever B towards Module A to fasten the connector to Module A. (See Fig. 3-3)

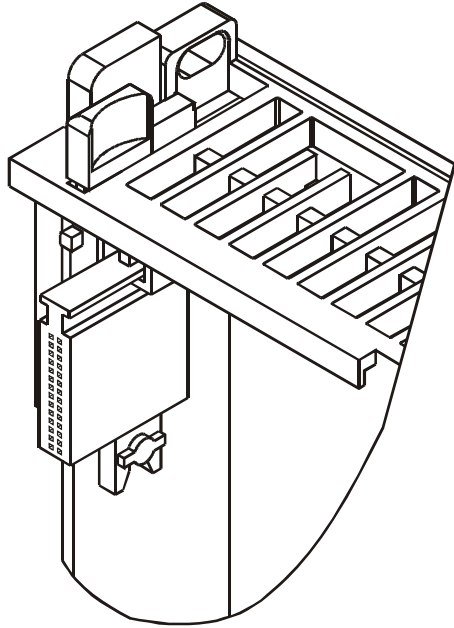

FIG. 3-3 CONNECTOR IN LOCKED POSITION

- Step 5. The installation is complete.

Installing the Module I/O Connector

About the Module I/O Connector

The I/O Connector at the front of the module connects the module to the Remote Terminal Assembly (-RTA), a load sensor, or the HI 215IT Series Junction Box depending on how many load sensors are installed in the weighing system. See below for the pin-out diagram. The pin-out diagram is located on the inside of the module door. (See Fig. 3-4)

Single Channel	
Pin 1	Shield1
Pin 3	C2-1
Pin 5	C2+1
Pin 7	Exc-1
Pin 9	Sen-1
Pin 11	Sig-1
Pin 13	Sig+1
Pin 15	Sen+1
Pin 17	Exc+1

Dual Channel			
Pin 1	Shield1	Pin 2	Shield2
Pin 3	C2-1	Pin 4	C2-2
Pin 5	C2+1	Pin 6	C2+2
Pin 7	Exc-1	Pin 8	Exc-2
Pin 9	Sen-1	Pin 10	Sen-2
Pin 11	Sig-1	Pin 12	Sig-2
Pin 13	Sig+1	Pin 14	Sig+2
Pin 15	Sen+1	Pin 16	Sen+2
Pin 17	Exc+1	Pin 18	Exc+2

- Step 1. Open the Module door to gain access to the I/O connector. (See Fig. 3-4)
- Step 2. To make the cable connections easier you can remove the connector from the module. To remove the connector, use a phillips screw driver and remove the two (2) phillips pan head screws that fasten the connector to the module. (See Fig. 3-5)
- Step 3. Gently pull the connector off of the board in the module.

HI 1769-WS/HI 1769-2WS WEIGH SCALE MODULE

- Step 4. To install the connector reverse steps 2 & 3.

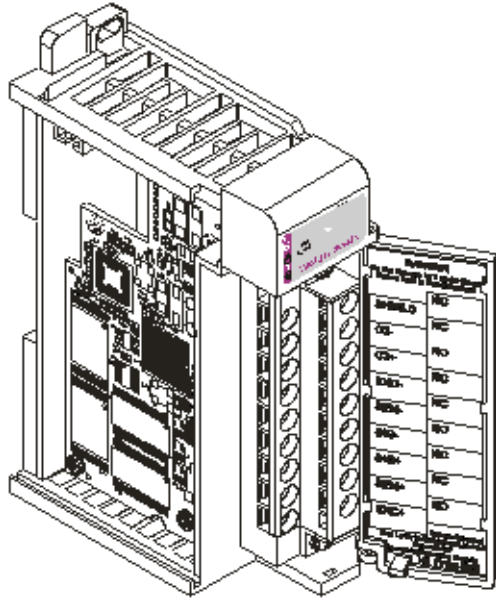

FIG. 3-4 MODULE CONNECTOR INSTALLED

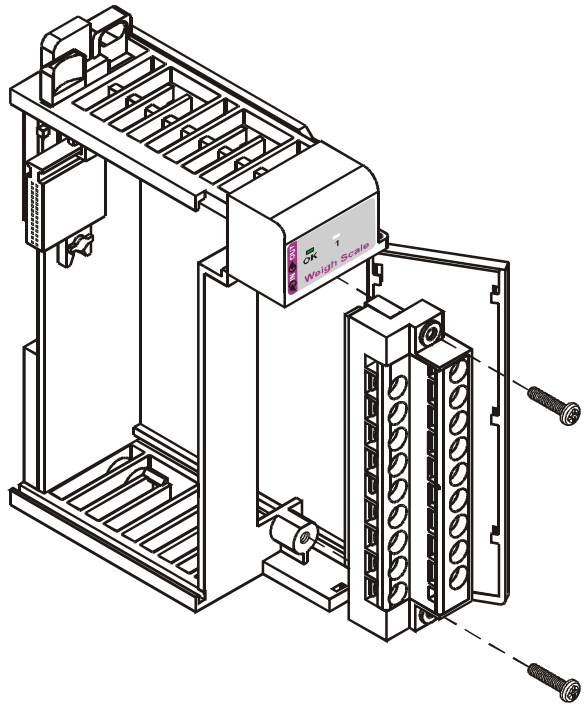

FIG. 3-5 MODULE CONNECTOR REMOVED FOR EASIER CABLING

- Step 5. Install the cable so it allows the module door to close.
- Step 6. Check to be sure that the wires are securely connected before operating the module.

NOTE:

Most of the problems with modules are due to loose connections. Be sure to check the I/O connection first in the event you have a problem receiving information from the load cells.

Installing the HI 1769-WS on a Din Rail

- Step 1. Pull the two DIN rail fasteners out until they snap into the open position. (See Fig. 3-6)

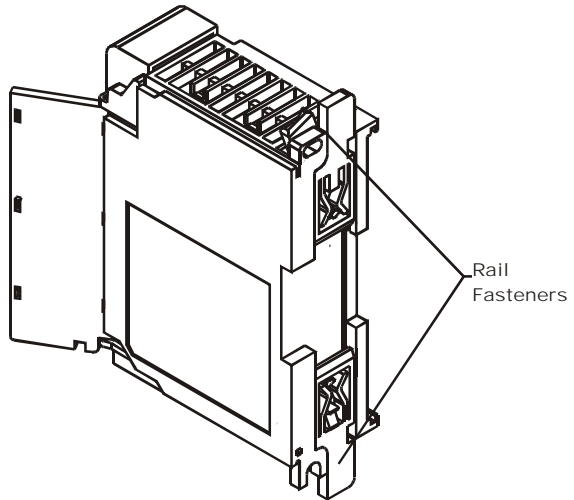

FIG. 3-6 RAIL FASTENERS IN RETRACTED POSITION

- Step 2. Place the module on the DIN rail.
- Step 3. While holding the module in place, press the two rail fasteners towards the center of the module until they both snap into place. (See Fig. 3-7)
- Step 4. The module is now securely fastened to the DIN Rail.
- Step 5. To remove the module from the DIN rail reverse steps 2 & 3 above.

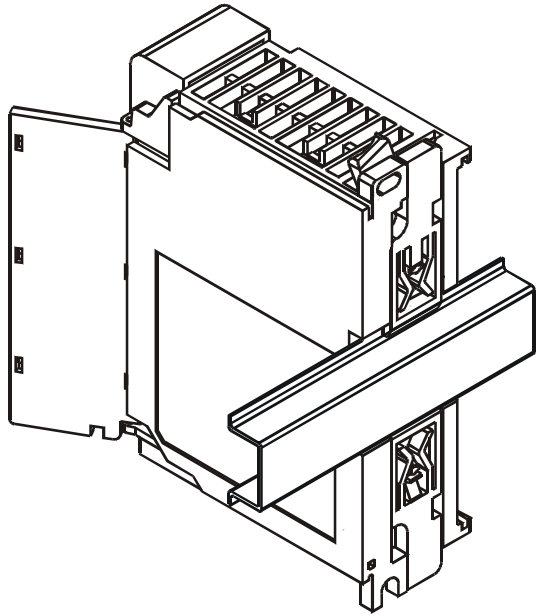
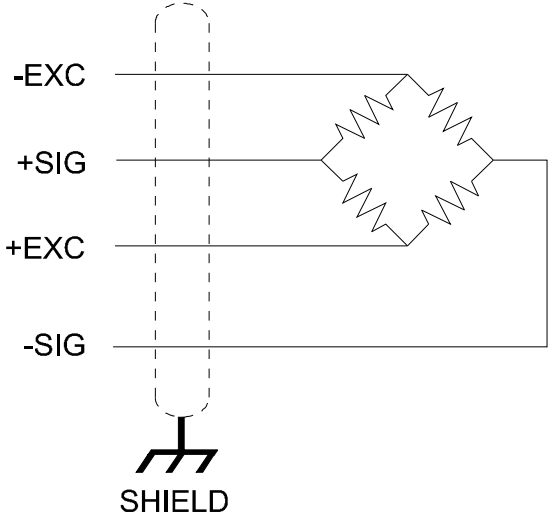

FIG. 3-7 RAIL FASTENERS IN THE CLOSED POSITION

**Load Cell Wiring
Diagrams**

**Industry Standard
Load Cells**



**FIG. 3-8 INDUSTRY STANDARD LOAD CELLS
WIRING DIAGRAM**

**Hardy Load
Sensor with C2**

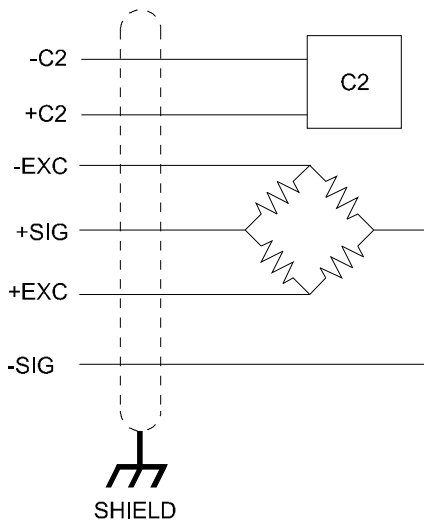

**FIG. 3-9 HARDY LOAD SENSOR/C2 WIRING
DIAGRAM**

WARNING:

HARDY PROCESS SOLUTIONS RECOMMENDS THAT YOU DO NOT CUT YOUR ADVANTAGE® OR ADVANTAGE LITE® LOAD SENSOR CABLE, BECAUSE YOUR C2® ACCURACY WILL BE AFFECTED AND THE WARRANTY VOIDED.

**HI 1769 Remote
Terminal
Assembly
(HI 1769-XX-RT)**

Provides connection points between the cable assembly from the HI 1769-WS module and the individual wires from the junction box(es) or load sensor(s). (See Fig. 3-10) The RTA can be mounted on a DIN Rail. (See Fig. 3-11)

HI 1769-WS/HI 1769-2WS WEIGH SCALE MODULE

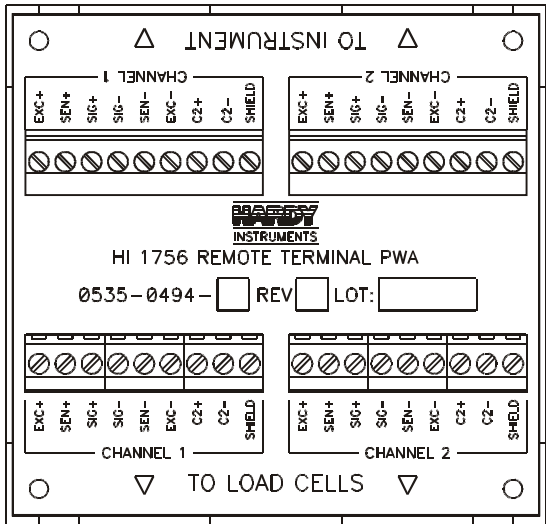

FIG. 3-10 REMOTE TERMINAL ASSEMBLY

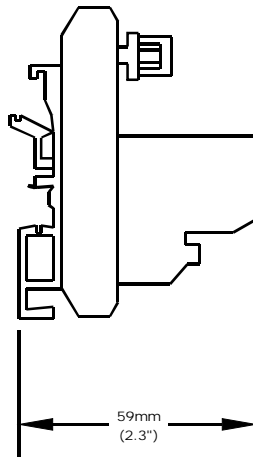

FIG. 3-11 RTA DIN RAIL MOUNT

RTA Cable Assembly

- Six (6) foot cable and schematic that connects to the HI 1769-WS module. (See Figs. 3-12& 3-13)

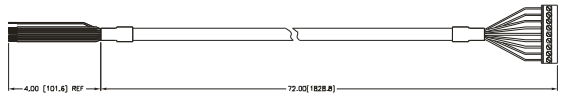

FIG. 3-12 RTA CABLE ASSEMBLY - HI 1769-WS

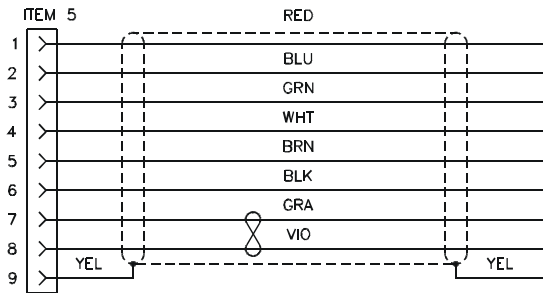

FIG. 3-13 RTA CABLE SCHEMATIC - HI 1769-WS

- Six (6) foot cable that connects to the HI 1769-2WS. (See Figs. 3-14 & 3-15)

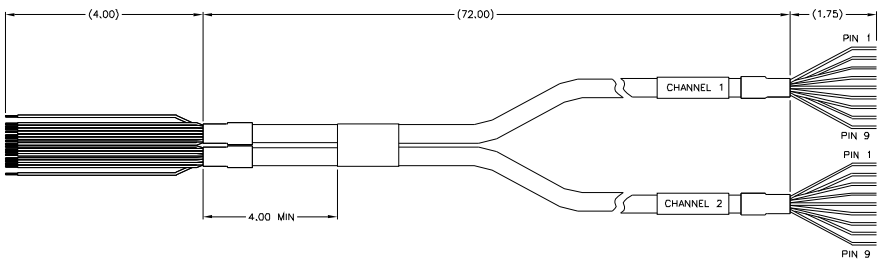

FIG. 3-14 RTA CABLE - HI 1769-2WS

HI 1769-WS/HI 1769-2WS WEIGH SCALE MODULE

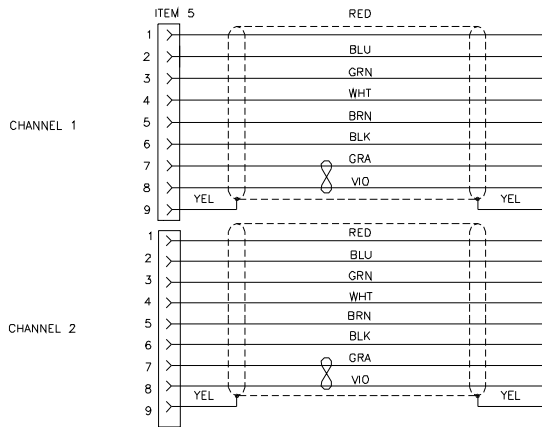

FIG. 3-15 RTA SCHEMATIC HI 1769-2WS

EMI Suppression Core Installation (Prt. #2547-0013)

For CE requirements you will need to install an EMI suppression core around the multi-strand portion of the RTA cable. (See Fig. 3-12 & 3-14)

NOTE:

Install one suppression core for the single channel model and two (2) suppression cores for the dual channel model.

- Step 1. There should be enough of the individual strands of wire exposed to install the suppression core. If there is not enough room, remove enough of the cable cover until you can place the suppression core around all the wire strands.
- Step 2. Place the suppression core as close to the module door as possible and still be able to close the door.
- Step 3. To open the suppression core place a small slotted screwdriver behind the latch and pry the latch away from the body of the core until it clears both catches. (See Fig. 3-16)

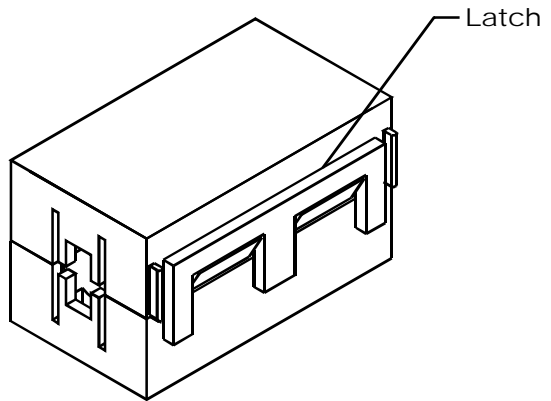

FIG. 3-16 EMI SUPPRESSION CORE

- Step 4. Open the core until it is wide enough to enclose all the strands of wire. (See Fig. 3-17)

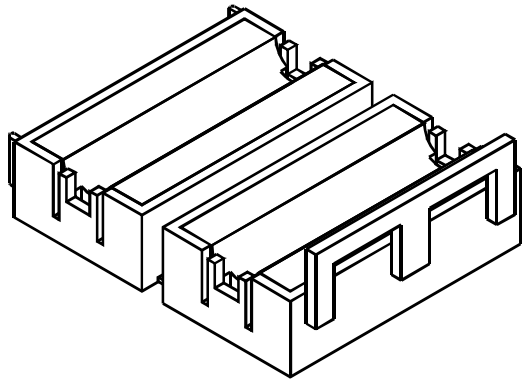

FIG. 3-17 SUPPRESSION CORE OPEN

- Step 5. Place all the wire strands in the core and gently close the core until it snaps shut. (See Fig. 3-18)

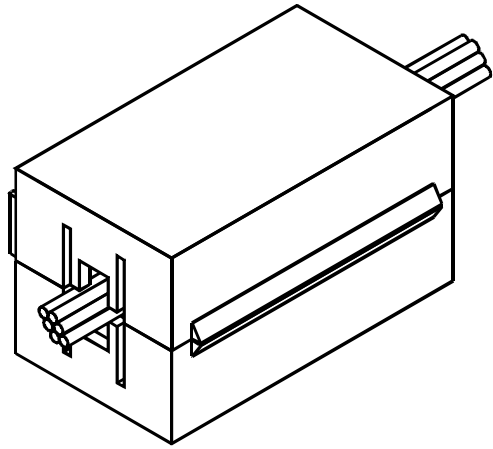

FIG. 3-18 SUPPRESSION CORE INSTALLED

**Hardy HI 215IT
Junction Box**

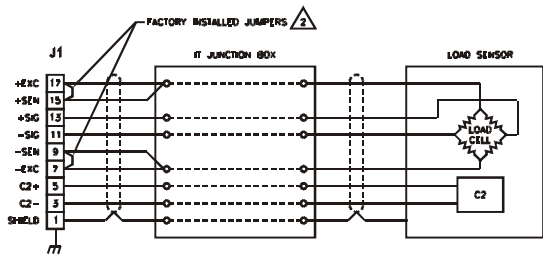

FIG. 3-19 HARDY HI 215IT JUNCTION BOX
WIRING DIAGRAM

NOTE:

When connecting the Hardy HI 215IT Junction Box you must remove the two factory installed jumpers 17&15 and 7&9 on the module install sense lines except when installing four (4) wire non C2 load cells.

CHAPTER 4 - SETUP

A Brief Description of Chapter 4

All information contained in Chapter 4 pertains to firmware and software settings to prepare the module controller for calibration and operation. Alternatives to these procedures either explicit or implied, contained in this section are not recommended. It is very important that the user and service personnel be familiar with the procedures contained in this chapter, before going through the setup procedures. The Setup procedures require Allen-Bradley's RS Logix 5000 (CompactLogix) or RS Logix 500 (MicroLogix 1500) Allen-Bradley RSLinx™ or RSLinx™ Lite.

Power Check

- Step 1. Check to see that there is power to the PLC and the module.
- Step 2. If there is power to the module, the LEDs should be lit. (See Fig. 4-1 and 4-2)
- Step 3. To make any settings the LED's should be lit for normal operation:

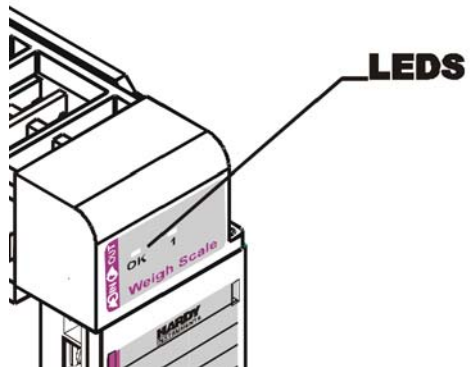

FIG. 4-1 MODULE LEDs HI 1769-WS SINGLE CHANNEL

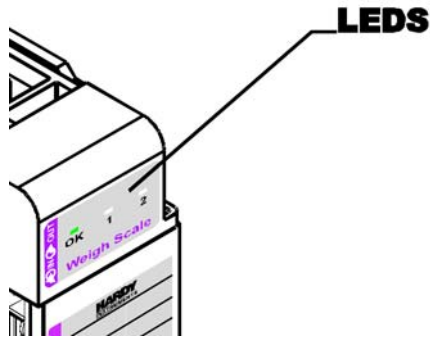

FIG. 4-2 MODULE LEDES HI 1769-2WS DUAL CHANNEL

LEDS

The module has a Scale LED and an OK LED associated with it. The LEDs may be green, red or off. They may be steady, Fast Flashing (5 Hertz) or Slow Flashing (1 Hertz)

Scale Data LEDs

Steady Green	Running (Normal)
Slow Flashing Green	Error No Calibration
Steady Red	Error ERRORADFAILURE - (hardware induced) status bit is set.
Flashing Red	Read AD Convert Error.
LED is Off	Channel is not Enabled

OK Module Status LED

Fast Flashing Green	Module communicating with PLC. (Normal)
Slow Flashing Red	Module is not Communicating with the PLC (Not Normal) Error, configuration/error in PLC addressing

NOTE:

Slow Flashing Red appears briefly when powering up.

NOTE:

**Contact Hardy Customer Support for assistance.*

**Setting Up
Communications
Between the
MicroLogix 1500
Processor and the
HI 1769-WS & HI 1769-
2WS Weigh Scale
Modules**

NOTE:

On the side of the module you will see a label that reads either Firmware REV A or Firmware REV B,C,D etc. Both setup procedures are the same except for the Connection Parameters/Extra Data Length. For REV A the setting is 0. For all other REVs the setting is 48.

To set up communication between the MicroLogix 1500 Processor and the Weigh Scale Module you will need to do the following in RSLogix 500:

- Step 1. We assume you have a project open or have created a new project. For instructions please see your RS LOGIX 500 manual. The setup instructions begin from this point.
- Step 2. From the I/O Configuration dialog box, under “#” column heading click on #1 or the next open slot number available. (See Fig. 4-3)

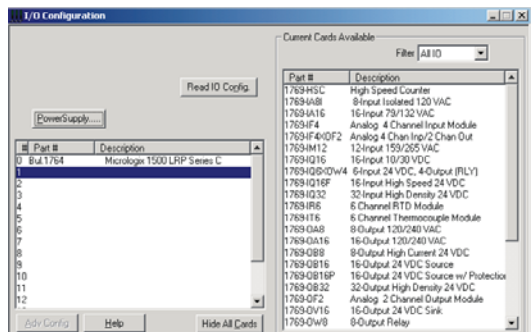

FIG. 4-3 I/O CONFIGURATION DIALOG BOX

HI 1769-WS/HI 1769-2WS WEIGH SCALE MODULE

- Step 3. Click on the “Read IO Config” button.
(See Fig. 4-4) The “Read IO Configuration from Online Processor” dialog box appears. (See Fig. 4-5)
- Step 4. RSLogix 500 automatically reads the I/O information and enters them into the configuration text fields. (See Fig. 4-4)

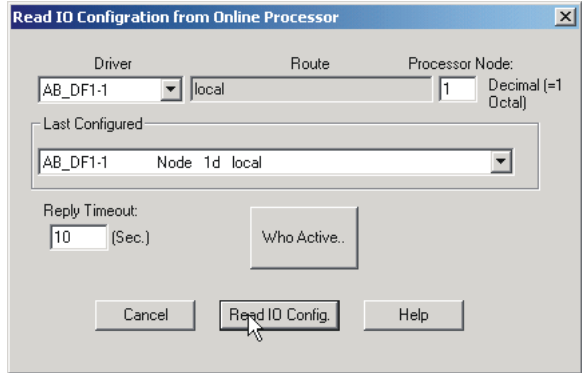

FIG. 4-4 READ I/O CONFIGURATION FROM ONLINE PROCESSOR DIALOG BOX

- Step 5. The HI 1769-WS I/O is configured and ready to communicate with the MicroLogix 1500 Processor.
- Step 6. For Firmware REV B you need to double click on the module which opens the Connection Parameters dialog box. Change the Extra Data Length from a 0 to 48. (See Fig. 4-5)

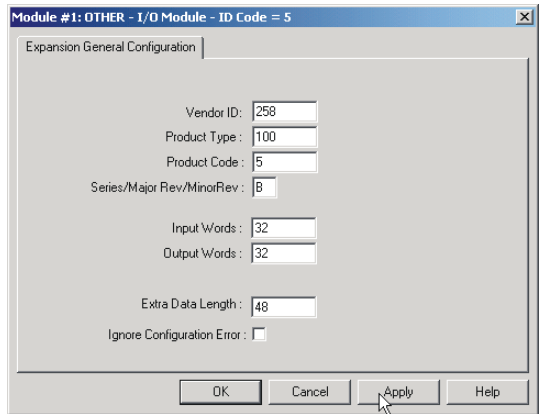

FIG. 4-5 CONNECTION/CONFIGURATION - 48

Alternative Setup Procedures

Configuring the HI 1769-WS in RSLogix 500 for MicroLogix 1500

To set up communication between the MicroLogix 1500 Processor and the Weigh Scale Module you will need to do the following in RSLogix 500:

- Step 1. Under Project, click on the + next to controller. (See Fig. 4-6)
- Step 2. Click on I/O Configuration. The I/O Configuration dialog box appears. (See Fig. 4-7)

HI 1769-WS/HI 1769-2WS WEIGH SCALE MODULE

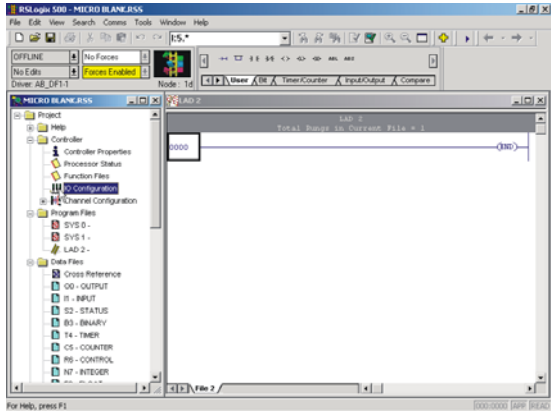

FIG. 4-6 EXPANDING CONTROLLER

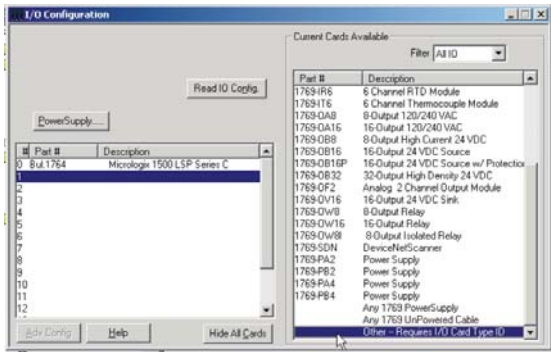

FIG. 4-7 I/O CONFIGURATION DIALOG BOX

- Step 3. From the I/O Configuration dialog box, under the “#” column heading, click on #1 or the next open slot number available. (See Fig. 4-8)
- Step 4. In the Current Cards Available, double click on “Other - Requires I/O Type Card ID” under the Description column heading.
- Step 5. Enter the following in the appropriate text fields:

On some PLC platforms it may be necessary to enter the Vendor ID, the Product Type, the Product Code, Input/Output Words and Extra Data Length. See below:

- HARDY_VENDOR_ID 0x102 (258 decimal)
- HARDY_PRODUCT_TYPE 0x54 (100 decimal)
- HARDY_PRODUCT-CODE 5
- Input Words - 32
- Output Words - 32
- Extra Data Length - 0 for Firmware REV A or 48 for later Firmware REVs.

Step 6. Click on the “Apply.” button.

Step 7. “OTHER” appears under the Part # column heading. (See Fig. 4-8)

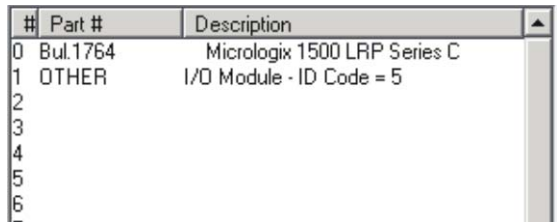

#	Part #	Description
0	Bul.1764	Micrologix 1500 LRP Series C
1	OTHER	I/O Module - ID Code = 5
2		
3		
4		
5		
6		

FIG. 4-8 I/O CONFIGURATION DIALOG BOX

Step 8. The HI 1769-WS I/O is configured and ready to communicate with the MicroLogix 1500 Processor.

Configuring the HI 1769-WS in RSLogix 5000 for CompactLogix

To set up communication between the CompactLogix Processor and the Weigh Scale Module you will need to do the following in RSLogix 5000:

Step 1. Click on the + next to I/O Configuration. (See Fig. 4-9).

HI 1769-WS/HI 1769-2WS WEIGH SCALE MODULE

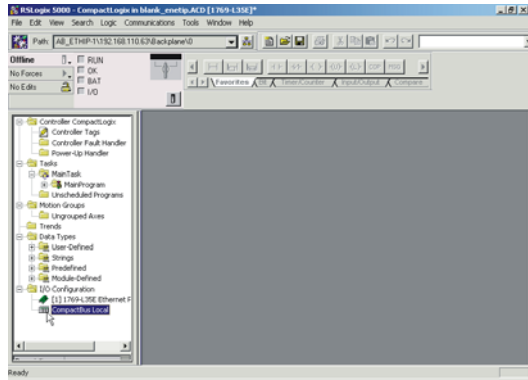
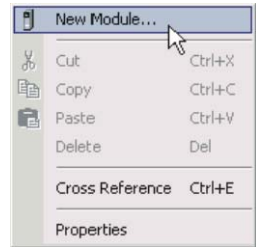
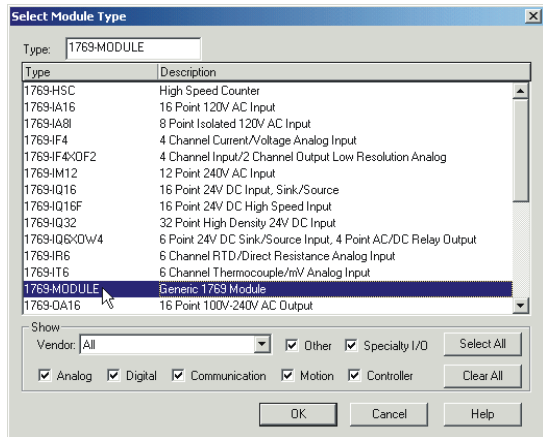

FIG. 4-9 SELECTING COMPACTBUS LOCAL

Step 2. Right click on “CompactBus Local”. A dialog box appears.



Step 3. Click on “New Module”. The “Select Module Type” dialog box appears. (See Fig. 4-10)



**FIG. 4-10 SELECT MODULE TYPE/
SELECTING 1769 MODULE/GENERIC**

- Step 4. From the Select Module Type dialog box, scroll down the list until you find the 1769 Module - Generic Module.
- Step 5. Double click on the 1769 Generic Module.
- Step 6. Click on the OK button. The Module Properties dialog box appears. (See Figs. 4-11 & 12)

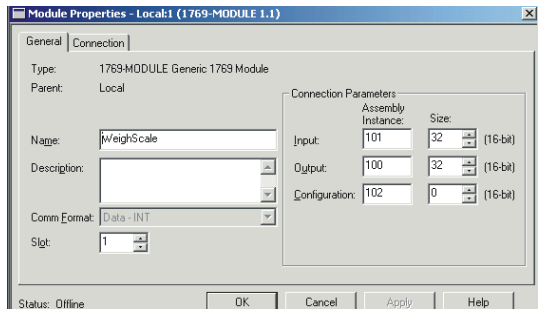

FIG. 4-11 MODULE PROPERTIES DIALOG BOX/CONFIGURATION/SIZE/0 WORDS

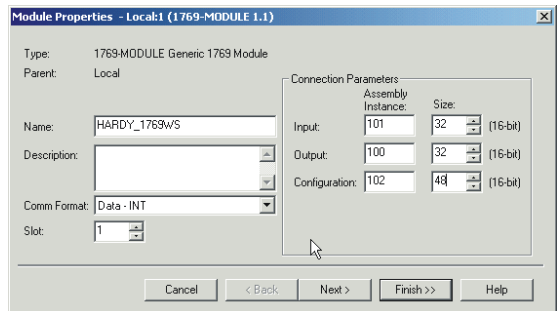

FIG. 4-12 MODULE PROPERTIES DIALOG BOX/CONFIGURATION/SIZE/48 WORDS

- Step 7. Click in the Name Text box. Enter a descriptive name for the module. We used “Hardy_1769WS” for example.

HI 1769-WS/HI 1769-2WS WEIGH SCALE MODULE

- Step 8. Click in the Description Text Box. Type in a description of the module.
- Step 9. Click on the down arrow to the right of Comm Format to open the pull down list.
- Step 10. Click on Data-INT to select the Comm Format.
- Step 11. Use the up or down arrows to the right of Slot, to select the slot number for the installed HI 1769-WS or HI 1769-2WS.
- Step 12. Under Connection Parameters/Input use the up or down arrows to select 32 words.
- Step 13. Under Connection Parameters/Output use the up or down arrows to select 32 words.
- Step 14. Under Connection Parameters/Configuration use the up or down arrows to select:
 - For Firmware REV A - 0 words.
 - For other Firmware REVs - 48 words.
- Step 15. Click on the “Finish” button.

Parameters for the HI 1769-WS Module

About Parameters

The data types that can appear in the I/O files are:

- 16 bit integer
- 32 bit integer
- 32 bit IEEE float.

NOTE:

In the 32 bit types, the least significant word comes first, followed by the most significant word.

Weight values are displayed as either 32 bit integers, or as 32 bit float depending on the value of the “Metric” parameter. (See Parameter Table 4-1 below) Each channel has a CHANNEL STATUS WORD, with bits set to indicate the state of that channel. The bit values are:

- #define ERRORADCONVERT 0x0001
- #define ERRORADFAILURE 0x0002
- #define STATUSINMOTION 0x0040
- #define ERRORNOCAL 0x0080
- #define ERROREEPROMWRITE 0x0100
// an error occurred when writing to non-volatile memory
- #define NVRDEFAULTED 0x0200 // set if SETDEFAULTPARAMS command was given
- #define STATUSCHANENABLED 0x8000 // set if channel is enabled

Name	Description	Default
ChanActive	16 bit integer, set to 1 if the channel is active, 0 if not active	1
Metric	16 bit integer which determines the format of weight values. Metric is the sum of 3 fields: <ol style="list-style-type: none"> 1 If bit 7 is set (0x80), weight is displayed in Kilograms 2 If bit 6 is set (0x40), weight is displayed as a floating point 3. If bit 6 is not set, Weight is displayed as an integer, with the 3 least significant bits giving the number of decimal places 	0 (weight in pounds, integer format, 0 decimal places)
WAVERSAVER	16 bit integer 0 No WAVERSAVER 1 4 Hertz 2 2 Hertz 3 1 Hertz 4 0.5 Hertz 5 0.25 Hertz	3 (1 Hertz)

TABLE 4-1: PARAMETERS

HI 1769-WS/HI 1769-2WS WEIGH SCALE MODULE

Name	Description	Default
NumAverages	16 bit integer, 1-255	20
ZeroTrackEnable	16 bit integer 0 turns auto-zero tracking off 1 turns auto-zero tracking on	0
AutoZeroTolerance	32 bit weight value, format determined by value of Metric Parameter	10.0 lbs.
ZeroTolerance	32 bit weight value, format determined by value of Metric Parameter	10.0 lbs.
Motion Tolerance	32 bit weight value, format determined by value of Metric Parameter	5 lbs
tareweight	32 bit weight value, format determined by value of Metric Parameter.	0 lbs.
SpanWeight	32 bit weight value, format determined by value of Metric Parameter. Span Weight is the test weight used at the high step of a hard calibration	10,000.0 lbs
ROTimebase	16 bit integer, 1-1800 seconds	10 secs
CalLowWeight	32 bit weight value, format determined by value of Metric Parameter CalLowWeight is the test weight used at the low step of a hard calibration and as Ref Point for C2 Calibration	0 lbs

TABLE 4-1: PARAMETERS

Configuration Parameters for the HI 1769-WS Module

The HI 1769-WS & HI 1769-2WS are equipped with Firmware REV B have 48 words of configuration data. The HI 1769-WS Firmware REV B has 48 words of configuration data for CompactLogix and Extended Data on MicroLogix, 24 words per channel.

The configuration data is sent from the PLC to the HI 1769-WS module at power-up. The module uses these parameters provided that:

1. The parameters are in the correct range. Illegal values will be rejected.
2. The “CopyConfig” word (0 for channel 0, 24 for channel 1) is set to 1.
 - INT parameters are 2 byte integers
 - DINT parameters are 4 byte integers
 - REAL parameters are 4 byte IEEE floating point numbers

NOTE:

Parameters labeled “REAL or DINT” will be interpreted as floating point or integer according to the value of the “METRIC” parameter of the channel. If bit 6 (0x40) of METRIC is set the parameter is floating point. If bit 6 is not set, it is a fixed point integer, with 0-7 decimal places as determined the first 3 bits of the METRIC parameter.

Parameter	Offset (In Words)	Data Type
Ch0CopyConfig	0	INT
Ch0ChanActive	1	INT
Ch0Metric	2	INT
Ch0Waversaver	3	INT
Ch0NumAverages	4	INT
Ch0ZeroTrackEnable	5	INT
Ch0AutoZeroTolerance	6	REAL or INT
Ch0MotionTolerance	8	REAL or INT
Ch0ZeroTolerance	10	REAL or INT
Ch0SpanWeight	12	REAL or INT

HI 1769-WS/HI 1769-2WS WEIGH SCALE MODULE

Parameter	Offset (In Words)	Data Type
Ch0CalLowWeight	14	REAL or INT
Ch0ROctimebase	16	INT
Ch0CopyCal	17	INT
Ch0calzerocount	18	DINT
Ch0CalHighCount	20	DINT
Ch0Spare2	22	INT
Ch0Spare3	23	INT
Ch1CopyConfig	24	INT
Ch1ChanActive	25	INT
Ch1Metric	26	INT
Ch1Waversaver	27	INT
Ch1NumAverages	28	INT
Ch1ZeroTrackEnable	29	INT
Ch1AutoZeroTolerance	30	REAL or INT
Ch1MotionTolerance	32	REAL or INT
Ch1ZeroTolerance	34	REAL or INT
Ch1SpanWeight	36	REAL or INT
Ch1CalLowWeight	38	REAL or INT
Ch1ROctimebase	40	INT
Ch1CopyCal	41	INT
Ch1calzerocount	42	DINT
Ch1CalHighCount	44	DINT
Ch1Spare2	46	INT
Ch1Spare3	47	INT

It is important to note in CompactLogix that when you click on Controller Tags you will not get the

parameters in the form above. When you expand the slot you selected for the these parameters they will look like the following:

Local:1:C.Data[0]
Local:1:C.Data[1]
Local:1:C.Data[2]
Local:1:C.Data[3]
...and so on

These correspond directly to the parameters in the table above. (See Fig. 4-13)

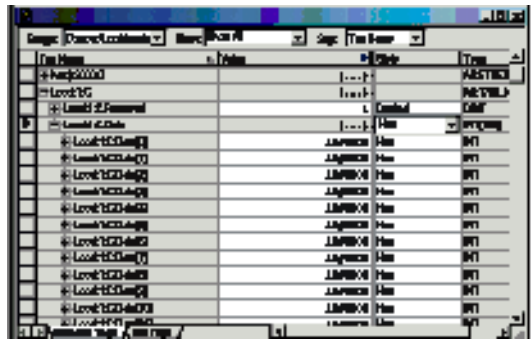

FIG. 4-13 CONTROLLER TAGS/SLOT 1

Commands

About Commands

The first 16 words are reserved for Channel 0. The second 16 words are reserved for Channel 1. The first word in the 16 words of a channel's output table is called the COMMAND word.

See the COMMAND table for a list of commands. The other words in the output data table may need to be set according to which command is being given. The commands are executed only once, when the COMMAND word changes. The first word in the channel's input table is an echo of the COMMAND word. All commands take some time to process; when you see the echoed value in the input table, the command is complete. The second word in the channel's

input table is called the command STATUS. Normally, a 0 value of STATUS means that the command completed OK and a non-zero status indicates some kind of error.

**Command
Operation**

- Step 1. To start a command, place the command number into the first word of the output table.
- Step 2. The Input Table contains the response for that command.
- Step 3. If a selected command needs other data with it, the other words in the output table should be filled in first, then the command number. Example:
 - WRITEPARAM0, should have PARAMETER0 Data placed into the output table before the command number is written, otherwise the command will fail.

**Possible
COMMAND
STATUS Values**

- #define SUCCESS 0
- #define ERRORADCONVERT 0x0001
- #define ERRORADFAILURE 0x0002
- #define STATUSINMOTION 0x0040
- #define OUTOFTOLERANCE -3
- #define INDEXOUTOFRANGE -4
- #define NOSUCHCMD -5
- #define C2FAILNODEVS -6
- #define C2FAILCAPEQ -7 // failure, capacities not equal
- #define HARDCALFAILCOUNST -8 // failure, not enough ADC counts between high, low

Command Table

Command	Required Output Table Values Written by User (PLC)	Input Table Response From Weigh Scale
<p>NOCMD (no command) 0 Give this command to read weight from the module. Weight values will then be continuously updated</p>	<p>O:0 = 0 O:1-0:15 (unused)</p>	<p>I:0 = 0 I:1 = COMMAND STATUS = 0 I:2 = CHANNEL STATUSWORD I:3 = Firmware Revision I:4 = Gross Weight, LSW I:5 = Gross Weight, MSW I:6 = Net Weight, LSW I:7 = Net Weight, MSW I:8 = Metric Parameter I:9 = Calibration Type <ul style="list-style-type: none"> • Hard Calibration = 0 • C2 Calibration = 1 • No Calibration = 0xFFFF I:10 = ADC Counts, LSW I:11 = ADC Counts, MSW I:12 = ROC (units/min) I:13 = ROC (units/min) I:14 = Serial Number I:15 = ADC Conversion Counter</p>
<p>ZEROCMD 1 Zeroes the scale: May fail if the weight is in motion, or if there is an A/D error, or if the weight to be zeroed out is outside the Zero Tolerance range.</p>	<p>O:0 = 1 O:1-0:15 (unused)</p>	<p>I:0 = 1 I:1 = COMMAND STATUS I:2-I:15 See NOCMD continuously updating</p>
<p>TARECMD 2 Tares the Scale: May fail if the weight is in motion, or if there is an A/D error.</p>	<p>O:0 = 2 O:1-0:15 (unused)</p>	<p>I:0 = 2 I:1 = COMMAND STATUS I:2-I:15 See NOCMD continuously updating</p>

HI 1769-WS/HI 1769-2WS WEIGH SCALE MODULE

Command	Required Output Table Values Written by User (PLC)	Input Table Response From Weigh Scale
<p>WRITEMETRIC 3 Writes the Metric Parameter. Does NOT save the value of the metric parameter to non-volatile memory.</p>	<p>O:0 = 3 O:1 - unused O:2 - unused O:3 - New METRIC value</p>	<p>I:0 = 3 I:1 = COMMAND STATUS I:2-I:15 See NOCMD, continuously updating</p>
<p>WRITENONVOLATILE 4 This command is normally not needed, since the commands that write parameters automatically save values to non-volatile memory. Exceptions are the ZEROCMD, TARECMD, and WRITEMETRIC, which do not automatically save.</p>	<p>O:0 = 4 O:1-O:15 (unused)</p>	<p>I:0 = 4 I:1 = 0 I:2-I:15 See NOCMD, continuously updating</p>
<p>RELOADNONVOLATILE 0X10 Reread the non-volatile memory</p>	<p>O:0 = 0x10 O:1-O:15 (unused)</p>	<p>I:0 = 0x10 I:1 = 0 I:2-I:15 See NOCMD continuously updating</p>
<p>CALLOWCMD 0x64 Do the low step of a Hard Calibration. Results saved to non-volatile memory.</p>	<p>O:0 = 0x64 O:1-O:15 (unused)</p>	<p>I:0 = 0x64 I:1 = COMMAND STATUS I:2-I:15 See NOCMD, continuously updating</p>
<p>CALHIGHCMD 0x65 Do the high setpoint of a Hard Calibration. Results saved to non-volatile memory.</p>	<p>O:0 = 0x65 O:1-O:15 (unused)</p>	<p>I:0 = 0x65 I:1 = COMMAND STATUS I:2-I:15 See NOCMD, continuously updating</p>
<p>C2CALCMD 0x66 Do a C2 Calibration. Results saved to non-volatile memory</p>	<p>O:0 = 0x66 O:1-O:15 (unused)</p>	<p>I:0 = 0x66 I:1 = COMMAND STATUS I:2-I:15 See NOCMD, continuously updating</p>

Command	Required Output Table Values Written by User (PLC)	Input Table Response From Weigh Scale
<p>WRITEPARAM0 0x67 Write a block of parameters: To write a single parameter:</p> <p>Step 1. Do a READPARAM0 command. Step 2. Copy the parameters read to the output. Step 3. Change the parameter value Step 4. Set the command word.</p> <p>The Metric Parameter is processed last, which means that all parameters are interpreted according to the old Metric value. Results are saved to non-volatile memory. If you attempt to set a parameter value to an illegal value, the offset of that parameter will appear in the COMMAND STATUS word.</p>	<p>O:0 = 0x67 O:1 = unused O:2 = ChanActive O:3 = Metric O:4 = WAVERSAVER O:5 = NumAverages O:6 = ZeroTrackEnable O:7 = ROTimebase (1-1800 sec) O:8 = AutoZeroTolerance, LSW O:9 = AutoZeroTolerance, MSW O:10 = MotionTolerance, LSW O:11 = Motion Tolerance, MSW O:12 = ZeroTolerance, LSW O:13 = ZeroTolerance, MSW O:14-O:15 = unused</p>	<p>I:0 = 0x67 I:1 = COMMAND STATUS I:2-I:15 See READPARAM0</p>
<p>WRITEPARAM1 0X68 If you attempt to set a parameter value to an illegal value, the offset of that parameter will appear in the COMMAND STATUS word.</p>	<p>O:0 = 0x68 O:1 = unused O:2 = TareWeight LSW O:3 = TareWeight MSW O:4 = SpanWeight LSW O:5 = SpanWeight MSW O:6 = CalLowWeight LSW O:7 = CalLowWeight MSW O:8-O:15 = unused</p>	<p>I:0 = 0x68 I:1 = COMMAND STATUS I:2-I:15 See READPARAM1</p>

HI 1769-WS/HI 1769-2WS WEIGH SCALE MODULE

Command	Required Output Table Values Written by User (PLC)	Input Table Response From Weigh Scale
<p>READPARAM0 0x69</p> <p>Read a parameter block. Weight values are formatted according to the Metric parameter.</p>	<p>O:0 = 0x69 O:1-O:15 = unused</p>	<p>I:0 = 0x69 I:1 = 0 I:2 = ChanActive I:3 = Metric I:4 = WAVERSAVER I:5 = NumAverages I:6 = ZeroTrackEnable I:7 = ROctimebase I:8 = AutoZeroTolerance, LSW I:9 = AutoZeroTolerance, MSW I:10 = MotionTolerance, LSW I:11 = MotionTolerance, MSW I:12 = ZeroTolerance, LSW I:13 = ZeroTolerance, MSW I:14-I:15 = unused</p>
<p>READPARAM1 0x6A</p> <p>Read a parameter block. This block contains some non-user settable calibration parameters zerocount = A/D counts at the last ZEROCMD calzerocount = A/D counts at zero weight, as obtained at the last calibration CalLowCount: A/D counts at CalLowWeight CalHighCount: A/D counts at Span Weight (Hard Calibration only)</p>	<p>O0 = 0x6A O:1-O:15 = unused</p>	<p>I:0 = 0x6A I:1 = 0 I:2 = tareweight LSW I:3 = tareweight MSW I:4 = SpanWeight LSW I:5 = SpanWeight MSW I:6 = CalLowWeight, LSW I:7 = CalLowWeight, MSW I:8 = zerocount, LSW I:9 = zerocount, MSW I:10 = calzerocount, LSW I:11 = calzerocount, MSW I:12 = calLowCount, LSW I:13 = calLowCount, MSW I:14 = calHighCount, LSW I:15 = calHighCount, MSW</p>

Command	Required Output Table Values Written by User (PLC)	Input Table Response From Weigh Scale
<p>STABILITYTEST 0x6B</p> <p>Switch in a specified signal in place of the normal load cell signal. With an IT-JBOX, 4 individual load cell signals, or a reference signal on the JBOX may be switched in.</p> <p>Without an IT-JBOX, only an onboard reference signal may be switched in.</p> <p>Giving any other command after STABILITYTEST causes the unit to return to normal operation.</p>	<p>O:0 = 0x6B O:1 = signal to switch in O = onboard reference signal 1-4 = load cell signals on IT-JBOX 5 = reference signal from IT-JBOX</p>	<p>I:0 = 0x6B I:1 = COMMAND STATUS</p> <p>NOTE: <i>The COMMAND STATUS INDEXOUTOFRANGE (-4) is returned if a signal outside the 0-5 range is requested, if you have an IT-JBOX, or if a signal other than 0 (onboard reference signal) is requested and you do not have an IT-JBOX.</i></p> <p>I:2-I:15 See NOCMD, continuously updating</p> <p>NOTE: <i>During the Stability Test, Gross and Net Weights are results of signal selected for this test.</i></p>

HI 1769-WS/HI 1769-2WS WEIGH SCALE MODULE

<p>TESTRESULTS 0x6C Report the results of a previous INTEGRATED TECHNICIAN test. No new test is performed</p>	<p>O:0-0x6C O:1-15 (unused)</p>	<p>I:0x6C I:1 = return to zero test result, bit coded:</p> <ul style="list-style-type: none">• Bits set to 1 indicate non-return to zero.• Bit 0 = combined weight• Bits 1-4 (JBOX only) indicate non-return to zero on a individual JBOX sensor. <p>I:2-15 are all INTEGER values.</p> <ul style="list-style-type: none">• Millivolt/volt readings have 4 decimal places.• Load Cell resistance has zero decimal places.• Sense Volts has 2 decimal places. <p>I:2 = millivolts/volt, combined, LSW I:3 = millivolts/volt combined, MSW I:4 = millivolts/volt, load sensor #1, LSW I:5 = millivolts/volt, load sensor #1, MSW I:6 = millivolts/volt, load sensor #2, LSW I:7 = millivolts/volt, load sensor #2, MSW I:8 = millivolts/volt, load sensor #3, LSW I:9 = millivolts/volt, load sensor #3, MSW I:10 = millivolts/volt, load sensor #4, LSW I:11 = millivolts/volt, load sensor #4, MSW I:12 = Sense Volts, LSW I:13 = Sense Volts, MSW I:14 = Load cell input resistance, as determined from C2 at last calibration, LSW I:15 = Load cell input resistance, MSW</p>
---	-------------------------------------	---

<p>WEIGHSYSTEST 0x6D Perform an INTEGRATED TECHNICIAN test.</p>	<p>O:0=0x6D O:1 = number of sensors O:2-15 (unused)</p>	<p>I:0 = 0x6D I:1 = number of sensors I:2-15 are weight values, scaled according to the Metric Parameter value I:2 = combined gross weight, LSW I:3 = combined gross weight, MSW I:4 = gross weight on load sensor #1, LSW I:5 = gross weight on load sensor #1, MSW I:6 = gross weight on load sensor #2, LSW I:7 = gross weight on load sensor #2, MSW I:8 = gross weight on load sensor #3, LSW I:9 = gross weight on load sensor #3, MSW I:10 = gross weight on load sensor #4, LSW I:11 = gross weight on load sensor #4, MSW I:12 = Internal reference weight, LSW I:13 = Internal reference weight, MSW I:14 = JBOX reference weight, LSW I:15 = JBOS reference weight, MSW</p>
<p>C2SEARCH 0x6E Search for C2 load sensors. The COMMAND STATUS is the number of sensors found.</p>	<p>O:0=0x6E O:1-15 (unused)</p>	<p>I:0 = 0x6E I:1 = COMMAND STATUS I:2-I:15 See NOCMD, continuously updating</p>
<p>WEIGHSYSRESULTS 0x6F Report the results of a previous INTEGRATED TECHNICIAN test. No new test is performed.</p>	<p>O:0=0x6F O:1-15 (unused)</p>	<p>I:0=6F I:1-15 See WEIGHSYSTEST</p>

HI 1769-WS/HI 1769-2WS WEIGH SCALE MODULE

<p>READC2SERIALNUM 0x70</p> <p>Read data from a C2 sensor. The C2SEARCH command must be performed before this command is done.</p>	<p>O:0 = 0x70 O:1 = SENSOR NUMBER (0-7)</p>	<p>I:0 = 0x70 I:1 = COMMAND STATUS I:2-9 = Serial Number I:10 = Sensitivity, LSW I:11 = Sensitivity, MSW I:12 = Capacity, LSW I:13 = Capacity, MSW</p> <p>NOTE: <i>Sensitivity is an integer, with 4 decimal places and dimensions of millivolts per volt. Capacity is an integer with 0 decimal places, with units of pounds.</i></p>
<p>SETDEFAULTPARAMS 0x94</p>	<p>O:0 = 0x94 O:1-15 (unused)</p>	<p>I:0 = 0x94 I:1 = COMMAND STATUS I:2-I:15 See NOCMD, continuously updating</p>
<p>EXTENDED VERSION 0xFF</p> <p>Read full software version information</p>	<p>O:0 = 0xFF O:1-15 (unused)</p>	<p>I:0 = 0xFF I:1 = 0 I:2 = SERIES_REV I:3 = MAJOR_REV I:4 = MINOR_REV I:5 = PATCH_REV I:6 = BUILD_REV</p>

TABLE 4-2: COMMAND TABLE

Calibration Setup Procedures

Setting the Metric Parameter

The Metric Parameter can be set to either kilograms or pounds. Any weight value input to the module (e.g. CALLOWWEIGHT, SPANWEIGHT) are in the currently selected units. The unit of measure can be set at any time, not just at calibration. Setting the unit of measure before calibrating reminds the user what unit of measure is being displayed. It is important to note that the weigh scale module does not need to be calibrated again after changing the unit of measure.

Setting the Motion Tolerance Value

The motion tolerance is the tolerance value used to determine if the scale is in motion.

Setting The Zero Tolerance Value

Sets the range of weights so that the Zero Command works, as an offset of the calibrated Zero.

Setting the Auto Zero Tolerance Value

When the Auto Zero Tolerance is entered, and Auto Zero Tracking is enabled, any weight within the entered tolerance of zero and not in motion, will cause the display to automatically read zero.

NOTE:

There is a short time delay (at least 1 second) before the AutoZero Triggers.

Setting the Number of Readings Averages

The Number of Averages sets the number of weight readings which will be used to compute the displayed weight. The average is a sliding average so that a new average reading is available for display at every reading.

Setting the Span Weight Value

The Span Weight is a reference point derived from an actual measured weight. This should not be confused with the scale capacity. If you have a 100 pound weight and you place it on the scale, the Span Weight is 100 pounds.

Setting the WAVERSAVER Value

There are 6 selectable levels, 0 means that WAVERSAVER has not been selected. Default setting is #3 1 Hertz.

- 0 = NO WAVERSAVER
- 1 = 4.0 Hertz
- 2 = 2.0 Hertz
- 3 = 1.0 Hertz - Default
- 4 = 0.5 Hertz
- 5 = 0.25 Hertz

HI 1769-WS/HI 1769-2WS WEIGH SCALE MODULE

CHAPTER 5 - CALIBRATION

A Brief Description of Chapter 5

Chapter 5 pertains to the calibration procedures for the HI 1769-WS and HI 1769-2WS Weigh Scale Modules. Alternatives to any procedures either implied or explicitly contained in this chapter are not recommended. In order for the Weigh Module to work properly, it must be calibrated prior to operation. It is recommended that the module calibration be verified periodically or when not in use for extended periods of time. Be sure to follow all the procedures completely to insure that the weights read by the module are accurate. It is very important that the user and service personnel be familiar with the procedures contained in this chapter, before installing or operating the Weigh Module.

NOTE:

Do not perform a calibration while the application is in operation.

Pre-Calibration Procedures

- Step 1. Check to determine if the load cells have been properly installed.
 - a. Refer to your load cell I&M manual for proper installation instructions.
 - b. On some sensors and cells there is an arrow that indicates the direction of the applied load. If the arrow is pointing in the wrong direction, change the position of the load cell so that it is mounted in the direction of the applied load.

- Step 2. Check for Binding on the Load Cell or other parts of the weighing system.

CAUTION:

BINDING ON A SCALE/VESSEL OR LOAD CELL DOES NOT ALLOW THE LOAD CELL FREE VERTICAL MOVEMENT AND MAY PREVENT THE INSTRUMENT FROM RETURNING TO THE ORIGINAL ZERO REFERENCE POINT.

- a. A load cell must be mounted in such a way that 100% of the load (Vessel w/ Contents) is vertically passed through a load cell. (See Fig. 5-1)
- b. Check to see that nothing is binding the load cell. This means that nothing is draped across the scale/vessel or the load cell, such as a hose, electrical cord, tubes, or other objects.
- c. Check to see that nothing is coming in contact with the scale/vessel other than service wires and piping that have been properly mounted with flexible connectors.

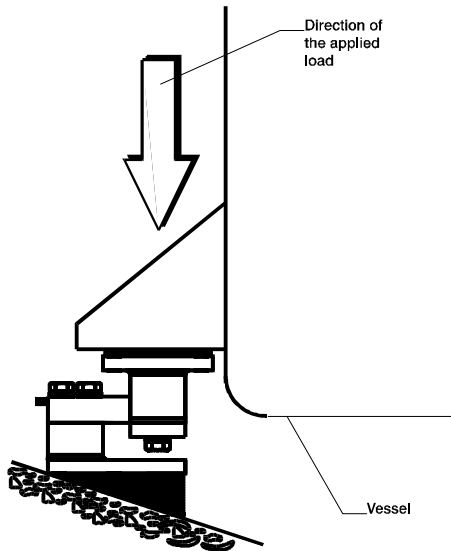

FIG. 5-1 PROPERLY INSTALLED LOAD CELL W/NO BINDING

**Electrical Check
Procedures**

**Load Cell/Point
Input/Output
Measurements**

Step 3. Typical Load Cell/Point Input/Output
Measurements (EXC & SIG Outputs)

- a. The Weigh Module is designed to supply 5 VDC excitation to as many as four (4) 350 Ohm load cells/points.
- b. The expected output from each load cell/point depends on the mV/V rating of the load cell/point and the weight.
- c. For example, a 2mV/V load cell/point will respond with a maximum of 10 mVDC at full weight capacity of the system which includes the weight of the vessel and the weight of the product as measured by the load cell/point.
- d. If the load cell/point weight capacity is rated at 1000 pounds, the load cell/point will be 10 mVDC at 1000 pounds, 7.5 mVDC at 750 pounds, 5 mVDC at 500 pounds and so on.
- e. A zero reference point will vary from system to system depending on the “Dead Load” of the vessel. “Dead Load” is the weight of the vessel and appurtenances only, with no product loaded. In our example we will assume the dead load to be 500 pounds. (See Fig. 5-2)

HI 1769-WS/HI-1769-2WS WEIGH SCALE MODULE

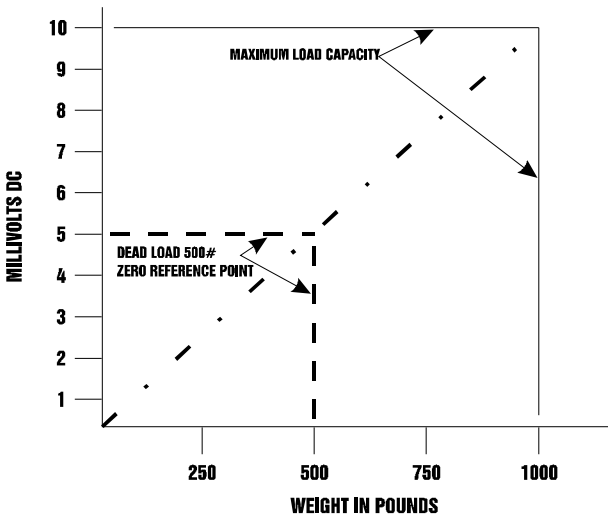

FIG. 5-2 MILLIVOLTS/WEIGHT SCALE

- f. Based on the example, the operating range for this scale is 5-10 mVDC with a 500 pound weight range. Understand that after zeroing the instrument, the 0 reading refers to the zero reference point and not absolute 0 mVDC or absolute 0 weight.

NOTE:

Load cell/point measurements are checked with a digital volt meter at the J1 connector on the front of the module or by using INTEGRATED TECHNICIAN with the HI 215IT Junction Box.

Load Check

- Step 1. Place a load (weight) on the scale or vessel.
- Step 2. Check to see if the weight reading changes on the ladder logic display in the proper direction.
- For example: If the ladder logic display reads 100 pounds and a 20 pound weight is placed on the vessel or

scale, the ladder logic display should read 120 or some value over 100.

- If the ladder logic display reads 100 pounds and a 20 pound load is placed on the vessel or scale and the reading is 80 pounds, the reading is going in the wrong direction and indicates some problem with the system.
- If the ladder logic display is reading improperly or shows no change there is something wrong with the setup.

Step 3. If the ladder logic display changed weight in the proper direction, remove the weight and proceed to calibrate the module.

C2 Calibration

About C2 Calibration

C2 calibration requires C2 load sensors. If you do not have C2 load sensors you must perform a traditional calibration with test weights which we call a Hard Calibration. The Weigh Module reads the performance characteristics of each individual load cell and detects the quantity of load cell(s) in the system. C2 Calibration can be performed via Allen Bradley RS LOGIX 5000/500.

C2 Calibration Using Ladder Logic

Step 1. Check to be sure that the parameters have been setup for your weighing process. (See Chapter 4, Setup)

Step 2. We have provided a Ladder Logic example explaining how to perform the C2 Calibration. The Ladder Logic example is available on the Hardy Web Site:

<http://www.hardysolutions.com>

Step 3. Click on “Support”.

Step 4. Click on “Sample Programs”.

Step 5. You will find the sample programs under the HI 1769-WS Heading.

Hard Calibration

Hard Calibration is the traditional method of calibration that uses test weights. Hardy recommends that the test weights total 80 to 100% of the scale capacity.

**Hard Calibration
Ladder Logic
Example**

- Step 1. Check to be sure that the parameters have been setup for your weighing process. (See Chapter 4, Setup)
- Step 2. We have provided a Ladder Logic example explaining how to set the weigh process parameters. The Ladder Logic example is meant to provide a ladder logic model only. Your application may vary and the example may or may not meet your requirements.
- Step 3. The Hard Calibration Ladder Logic Example is located at the Hardy Web Site. If you have access to the Internet:

- a. Type the following URL:

<http://www.hardysolutions.com>

- b. Click on the Support button.
 - c. Click on Sample Programs.
 - d. Click on the pull down menu for the product you are calibrating.
 - e. Click on the Ladder Logic Example for the HI 1769-WS Weigh Module, Hard Calibration.
- Step 4. If you do not have access to the Internet, call your local Hardy representative or Hardy Customer Service Center and we will forward you a hard copy of the calibration ladder logic explanation and ladder logic example.

CHAPTER 6 - TROUBLESHOOTING

A Brief Description of Chapter 6

All the information in Chapter 6 pertains to the troubleshooting and resolution of operating problems that may occur. All maintenance personnel and users should be familiar with Chapter 6 before attempting to repair the HI 1769-WS.

Scale LED is Flashing Red

Solution: Check all the connections to be sure they are securely fastened. Reinstall if any appear to be loose.

Mechanical Inspection

See Fig. 6-1

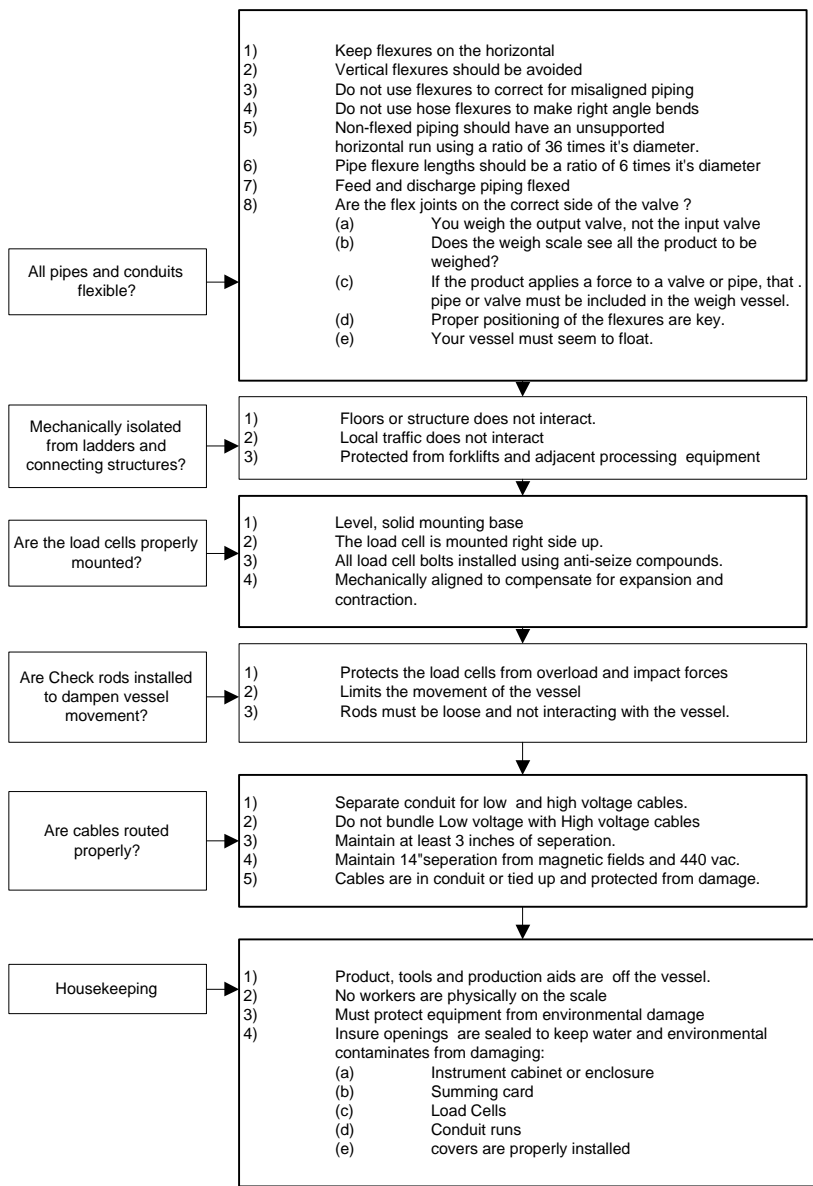

FIG. 6-1 MECHANICAL INSPECTION

**Load Sharing and
Load Sensor
Checkout**

See Figure 6-2

NOTE:

On balancing load cells, the overall objective is to insure each load cell sees a positive millivolt reading. When weight is evenly applied, all load cells signals should increase the same amount.

NOTE:

Insure the millivolt distribution is equal enough so not to overload any one load cell.

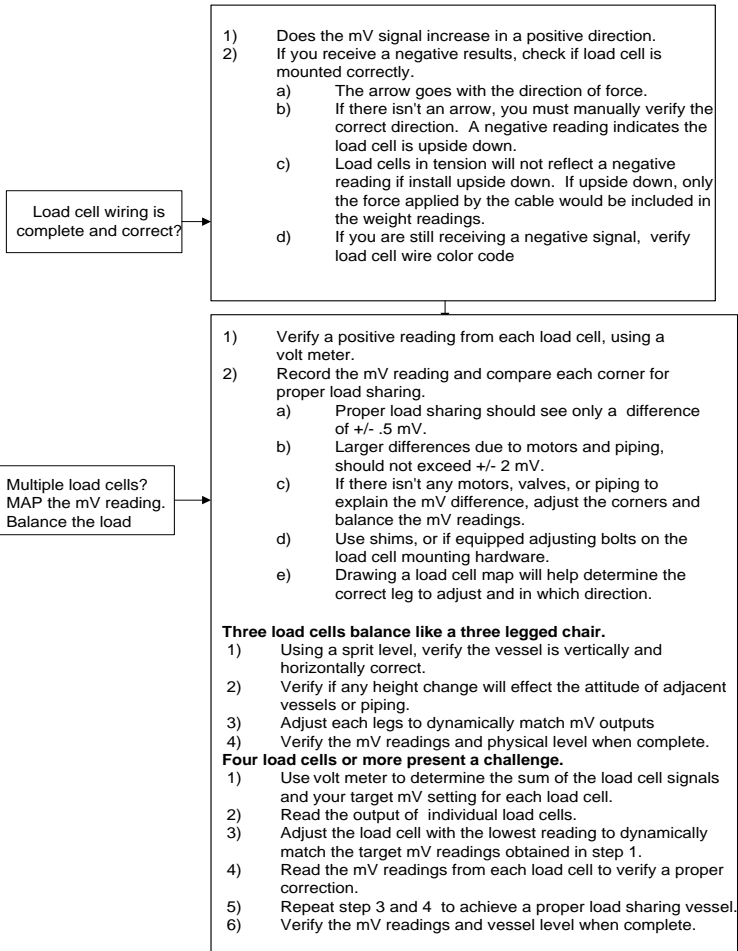

FIG. 6-2 LOAD SHARING AND LOAD SENSOR CHECKOUT

**Guidelines for
Instabilities on
Formerly Operating
Systems**

See Figure 6-3

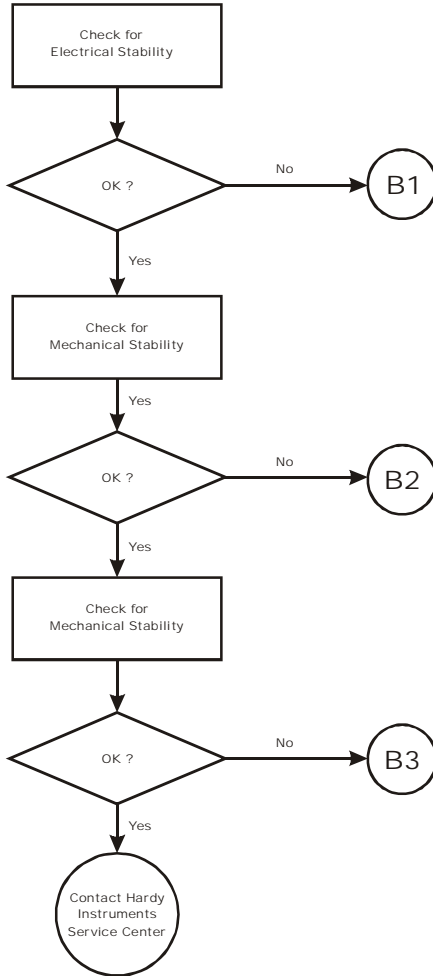

FIG. 6-3 GUIDELINES FOR INSTABILITIES ON FORMERLY OPERATING SYSTEMS

Electrical

See Figure 6-4

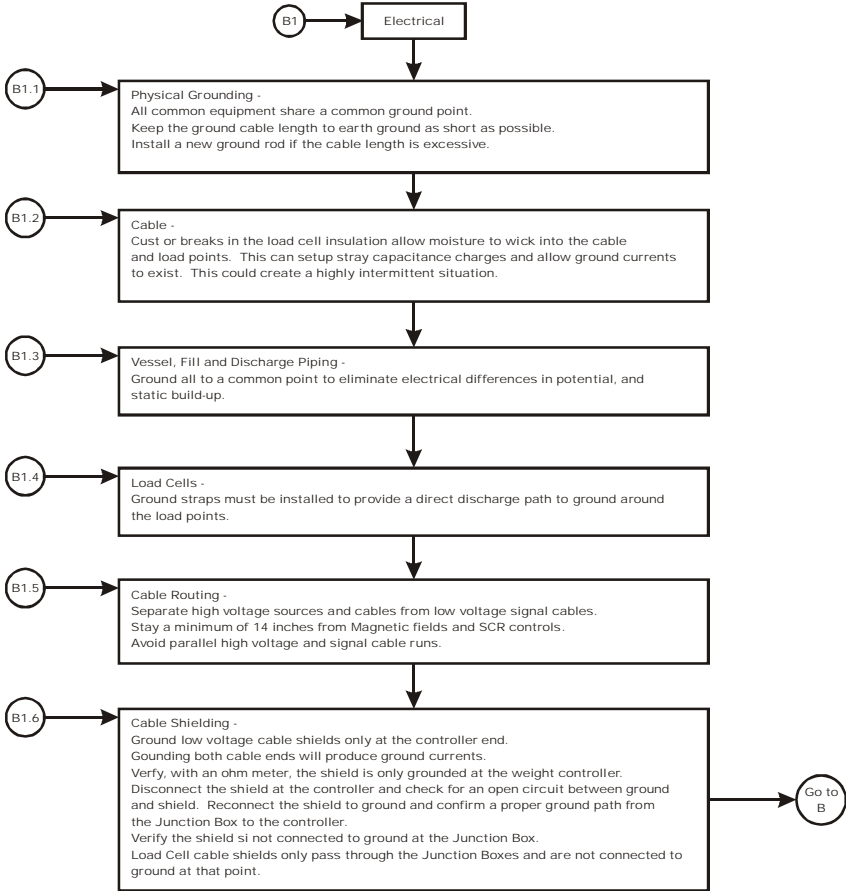
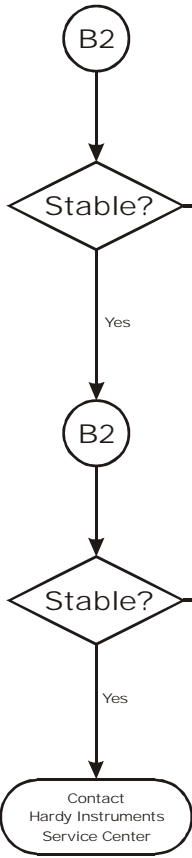

FIG. 6-4 GUIDELINES FOR INSTABILITIES ON FORMERLY OPERATING SYSTEMS - ELECTRICAL

Mechanical Stability and Configuration Settings

See Figure 6-5



Mechanical Stability

Vessel -
 When inspecting a vessel keep in mind, the Center of Gravity (COG) should be low and centered equally over all the load cells.
 Insure the load is directly over or under the load point to avoid side-loading. Make sure there isn't any side loading from piping or external forces. Install flexures on all piping to insure a free floating vessel.
 Insure the vessel and load cell mounts are mechanically stable and fixed. Large changes in individual load cells indicate a shift in COG or faulty load cells.

Piping and motors will effect effect the individual load cell readings.
 Allow for a higher reading on load cells that support motors and piping.
 Insure pneumatic lines are not applying pressure to the vessel when energized.

Use check (stay) rods to minimize vessel movement.
 Insure the check rods are loose and not interacting with the vessel.

Power down all vibration, vacuum and pressurization equipment during the test process.

Configuration Settings

Incorrect WAVERSAVER settings can cause unstable weight readings

Adjust to the lowest WS setting that gives you a stable reading.
Higher frequencicyes with low amplitude vibrations - Use WS settings 7.50 Hz or 3.50 Hz.
Low frequency with high amplitude vibrations - Use 0.50 Hz or 0.25 Hz

Adjust to the lowest WS setting that gives you a stable reading.
Higher frequencicyes with low amplitude vibrations - Use WS settings 7.50 Hz or 3.50 Hz.
Low frequency with high amplitude vibrations - Use 0.50 Hz or 0.25 Hz

Repeatability -
 Divide the total load cell capacity, including decimal points, by load cell divisions, 1,000 to 10,000

Resolution -
 Divide the total load cell capacity, including decimal points by 30,000
 (The amount you can expect to see, but not necessarily stable)

FIG. 6-5 MECHANICAL STABILITY AND CONFIGURATION SETTINGS

Index

Symbols

- “dead” loads 1-3
- “OTHER” 4-7
- “The Button” 1-3

Numerics

- 16 bit integer 4-10
- 1756 RTA (Remote Termination Assembly) 2-3
- 1769 Generic Module 4-9
- 2 Channel HI 1769-2WS 2-1
- 32 bit float 4-10
- 32 bit IEEE float 4-10
- 32 bit integer 4-10
- 32 bit integers 4-10
- 350 Ohm load cells/points 5-3
- 5 VDC excitation 5-3

A

- A Brief Description of Chapter 1 1-1
- A Brief Description of Chapter 2 2-1
- A Brief Description of Chapter 3 3-1
- A Brief Description of Chapter 4 4-1
- A Brief Description of Chapter 5 5-1
- A Brief Description of Chapter 6 6-1
- abnormal mechanical forces 1-4
- About C2 Calibration 5-5
- About Commands 4-15
- About Hardy Manuals 1-2
- About Parameters 4-10
- About the Module I/O Connector 3-4
- AC or high voltage DC module 3-2
- Allen-Bradley CompactLogix® 1-1
- Allen-Bradley Control/Logix® 1-2
- Allen-Bradley ControLogix® 1-1
- Allen-Bradley RSLinx™ 4-1

HI 1769-WS/HI 1769-2WS MANUAL

Allen-Bradley's RS Logix 5000 4-1
analog to digital converter 1-3
Approvals 2-2
Auto Zero Tolerance 1-5
Auto Zero Tracking 1-5, 4-25
Averages 2-1

B

Backplane Current Load 2-2
Backplane Input Voltage 2-2
Backplane Power Load 2-2
Before signing 3-1
Binding 5-1

C

C2 Calibration 5-5
C2 Calibration Input 2-2
C2 Calibration Output 2-2
C2 Calibration Using Ladder Logic 5-5
C2 load sensors 5-5
C2® Calibration 1-3
cable 3-7
cable cover 3-14
Cable lengths 2-2
calibrated electronically 1-3
Calibration 1-2
Calibration Setup Procedures 4-24
CE requirements 3-14
Channel 0 4-15
Channel 1 4-15
CHANNEL STATUS WORD 4-10
Channels 2-1
Comm Format 4-10
Command Operation 4-16
COMMAND table 4-15
Command Table 4-17
Commands 4-15

Common-Mode Rejection 2-1
Common-Mode Voltage Range 2-2
CompactBus Local 4-8
CompactLogix 3-2
CompactLogix Processor 4-7
Configuration 1-2
configuration data 4-13
Connection Parameters dialog box 4-4
Connection Parameters/Configuration 4-10
Connection Parameters/Extra Data Length 4-3
Connection Parameters/Input 4-10
Connection Parameters/Output 4-10
ControlLogix I/O 1-2
Conversion Rate 2-1
Customer Support Department 1-1

D

damaged load sensors 1-4
Data-INT 4-10
Dead Load 5-3
Default Parameters 2-3
Description 1-2
Description Text Box 4-10
Digital Volt Meter 1-4
Digital Voltmeter 2-2
DIN rail fasteners 3-7
DINT 4-13
DVM 1-4
DVM readings 1-4

E

Electrical 6-6
Electrical Check Procedures 5-2
electrostatic discharge 3-2
EMI suppression core 3-14
EMI Suppression Core Installation 3-14
Environmental Requirements 2-2

EXC & SIG Outputs 5-2

F

Finish 4-10

Firmware REV A 4-3

Firmware REV B,C,D etc. 4-3

flexible connectors 5-2

Full IT functionality 1-4

G

Guidelines for Instabilities on Formerly Operating Systems 6-5

H

Hard Calibration 5-6

Hard Calibration Ladder Logic Example 5-6

Hardy HI 215IT Junction Box 3-16

Hardy Instruments C2 certified load sensors 1-3

Hardy Load Sensor with C2 3-11

HI 1756 Remote Terminal Assembly 3-11

HI 1769-WS Compact and Micro Logix I/O Weigh Scale Modules 1-1

HI 1769-XX-RT 3-11

HI 215IT Junction Box 1-4

HI 215IT Series Junction Box 1-4, 2-3, 3-4

high voltage cables 3-2

http

[//www.hardyinst.com](http://www.hardyinst.com) 5-5

Humidity Range 2-2

I

I/O Configuration 4-5

I/O Configuration dialog box 4-3, 4-6

I/O information 4-4

Illegal values 4-13

Industry Standard Load Cells 3-10

Input 2-1

Input Table 4-16

install 1-2

Installing the HI 1756-WS (-2WS) 3-2
Installing the HI 1769-WS on a Din Rail 3-6, 3-7
Installing the Module I/O Connector 3-4
integrated communication 1-1
Integrated Technician 5-4
Integrated Technician™ 1-4
IT 1-4

L

ladder logic 1-1
ladder logic display 5-4
Ladder Logic example 5-5, 5-6
LEDS 4-1, 4-2
Lever B 3-3
Load Cell Excitation 2-2
Load Cell Wiring Diagrams 3-10
Load Cell/Point Input/Output Measurements 5-2
Load Check 5-4
Load Sharing and Load Sensor Checkout 6-3
loose connections 3-7

M

Maximum Installed Modules 2-1
Mechanical Inspection 6-1
Mechanical Stability and Configuration Settings 6-7
METRIC 4-13
METRIC parameter 4-13
Metric” parameter 4-10
MicroLogix 1500 Bank 3-2
MicroLogix 1500 Processor 4-3, 4-4, 4-7
MicroLogix 1500 programmable controller 1-2
MicroLogix® 1500 1-1
Model and Serial number 3-1
Module Properties dialog box 4-9
motion tolerance 4-24
multi-strand portion 3-14
mV 1-4

HI 1769-WS/HI 1769-2WS MANUAL

mV/V rating 5-3
mV/V readings 1-4

N

Name Text box 4-9
NEVER touch the connector pins 3-2
Non-Linearity 2-1

O

OK Module Status LED 4-2
open the suppression core 3-14
Operating Temperature Range 2-2
Optional Equipment 2-3
over sizing of load cells/sensors 1-3
Overview 1-2

P

Parameters for the HI 1756-WS (-2WS) Module 4-15
Possible COMMAND STATUS Values 4-16
Pre-Calibration Procedures 5-1

R

Read IO Config” button 4-4
Read IO Configuration from Online Processor” dialog box 4-4
REAL 4-13
Remote Terminal Assembly 3-4
Remote Termination Assembly 1-2
Removing the Module from the Chassis 3-4
Report any damage 3-1
Resolution 2-1
Return to Zero Test 1-4
RS Logix 500 4-1, 4-3
RSLinx™ Lite 4-1
RTA Cable Assemblies 2-3
RTA Cable Assembly 3-12
rta din rail mount 3-12

S

- Sample Programs 5-5
- Scale Data LEDs 4-2
- Scale LED is Flashing Red 6-1
- Select Module Type 4-8
- Setting the Auto Zero Tolerance Value 4-25
- Setting the Metric Parameter 4-24
- Setting the Motion Tolerance Value 4-24
- Setting the Number of Readings Averages 4-25
- Setting the Span Weight Value 4-25
- Setting the WAVERSAVER Value 4-25
- Setting The Zero Tolerance Value 4-25
- Setting Up Communications Between the MicroLogix 1500 Processor and the HI 1769-WS Weigh Scale Module 4-3
 - single module 1-2
- Specifications 1-2
- Specifications for a Standard HI 1756-WS 2-1
- Storage Temperature Range 2-2

T

- Technical Publications Department 1-2
- Temperature Coefficient 2-2
- The I/O Connector 3-4
- Troubleshooting 1-2

U

- unlock position 3-3
- Unpacking 3-1

V

- Vendor ID 4-6
- vibratory forces 1-3

W

- WAVERSAVER® 1-3, 2-1
- Weigh Scale Module 1-1, 4-3
- Weighing System Test 1-4

HI 1769-WS/HI 1769-2WS MANUAL

Weighing System Tests 1-4

wrist-strap grounding device 3-2