

Angle thermocouple assemblies are those commonly used in industrial process heating applications requiring the use of "over-the-side" temperature sensors with special metal alloy, composite material, or silicon carbide protection tubes. Special construction designs are available. Assemblies may be shipped with the hot leg unattached for assembly at time of installation due to size limitations. Cold leg as standard is supplied as carbon steel.

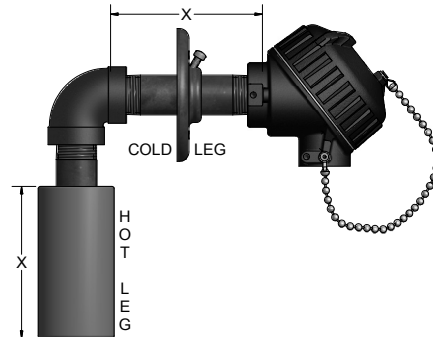
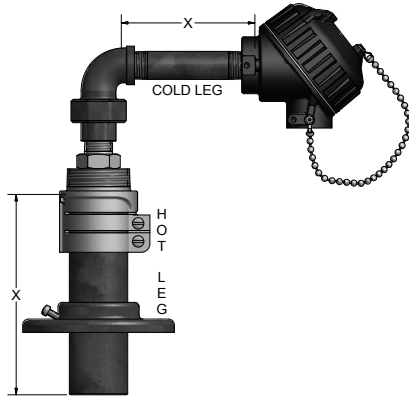

ORDER CODES

Example Order Number: **K8A** - **14-50** - **18** - **18** - **49, L**

1 Thermocouple Type and Wire Gauge Size

CODE	
K8A	N8A
K11A	
K14A	N14A

For duplex assemblies use the T/C type code letter twice.
Example: K14A - 12 - 75 becomes KK14A - 12 - 75.

2 Protection Tube Material NPT Connection

CODE	HOT LEG PROT. TUBE	TUBE O.D. or NPT SIZE (inches)
11 - 75	Cast-Iron	1.625
12WH	Metal Ceramic	0.875
13 - 75	Vesuvius	2.000
18J	Silicone Carbide	1.750
14 - 50 ^[1]	Cerite® II	1/2 NPT

[1] For protection tubes with 316SS pipe instead of a carbon steel pipe, change order number to 148.
Example: K8A-148-50-24-K.

3 Hot Leg "X" Length

LENGTH (inches)	LENGTH (inches)
12	30
18	36
24	

4 Cold Leg "X" Length

LENGTH (inches)	LENGTH (inches)
12	30
18	36
24	

Specify other lengths in 1" increments.

Code 14 Cerite® II actual length is one inch shorter than above.

5 Head Terminations

CODE	DESCRIPTION
31	Aluminum screw-cover head
34	Cast-Iron screw-cover head
49	Flip-top aluminum head
91	316L SS screw-cover head

5-1 Assembly Options

CODE	DESCRIPTION
SB	1/2 NPT conduit reducer bushing
GS	Ground screw
H	Adjustable steel mounting flange
HC	Adjustable steel flange (cold leg)
L	Insulated hot junction
UL	Steel union elbow
I	Stainless tag