

# Honeywell Primary Control Cross Reference

Page 1	R177, R180, R187, R190B, RA190B, R190C, R887, R890B RA890B, R890C, RA890C, RA890XB, XC, RA890D
Pages 2,3	RA890E
Page 4,5	RA890F
Page 6	RA890G
Page 7	RA890H, J, K
Page 8	R190C
Pages 9, 10	W124 or ID051
Page 11	R485
Pages 12,13	R4075
Page 14	R4138
Pages 15,16	R4795
Page 17	R7023
Page 18	R7795
Pages 19,20	Fireye™ TFM2,3, UVM2,3,5



**TABLE 1—CROSS REFERENCE**

Device To Be Replaced	Current Replacement	7800 Series Replacement ②③④	Wiring Number Number	Comments
R177A	RA890F ①	RM7890A1015	power—1,2 limit—1-5 motor—3 ignition—4 controller—R,W,B detector—F,G	Remove Series 10 Controller and rewire. Same as RA890F except does not have “proof of flame” terminal (terminal 5 on RA890E,F). Requires Q270A Subbase with RA890F. Requires Q7800F1004 Subbase with RM7890A1015.
R180A	RA890F ①	RM7890A1015	power—1,2 jumper—1-3 limit, main valve—4 controller—R,W,B detector—F,G	Continuous pilot applications only. Remove Series 10 Controller and rewire. Requires Q270A Subbase with RA 890F. Requires Q7800F1004 Subbase with RM7890A1015.
R180B	RA890F ①	RM7890A1015	power -1,2 limit, main valve—5 motor, pilot valve—3 ignition—4 controller—R,W,B detector—F,G	Functionality same as RA890F. Remove Series 10 Controller and rewire. Requires Q270A Subbase with RA890F. Requires Q7800F1004 Subbase with RM7890A1015.
R187A	RA890F ①	RM7890A10105	power—1,2 limit—1-5 motor—3 ignition—4 controller—R,W,B detector—F,G	Remove Series 10 Controller and rewire. Requires Q270A Subbase with RA890F. Requires Q7800F1004 Subbase with RM7890A1015.
R190B, RA190B	RA890F ①	RM7890A1015	See 180B	Remove Series 10 Controller and rewire. Requires Q270A Subbase with RA890F. Requires Q7800F1004 Subbase with RM7890A1015.
R190C	R4138C,D RA890H ④	RM7838A,B RM7890B1014	See Modernization Wiring Information section.	Used in W124 and ID051 panels. See Modernization Wiring Information section.
R887A	RA890F ①	RM7890A1015	power—1,2 limit—1-5 motor—3 ignition—4 controller—T,T detector—F,G	Rewire. Requires Q270A Subbase with RA890F. Requires Q7800f1004 Subbase with RM7890A1015.
R890B, RA890B	RA890F ①	RM7890A1015	power—1,2 limit—1 motor,pilot valve—3 ignition—4 main valve—5 controller—6 jumper—T,T detector—F,G	Requires Q7800F1004 Subbase with RM7890A1015.
R890C, RA890C	RA890F ①	RM7890A1015	Same as R890B, RA890B	Requires Q7800F1004 Subbase with RM7890A1015.
RA890XB RA890XC	RA890F ①	RM7890A1015	Same as R890B, RA890B	Requires Q7800F1004 Subbase with RM7890A1015.
RA890D	R4140M ①	RM7840M1017	Same as R890B, RA890B except controller always on terminal 6 and LF switch to T,T	Requires Q520A Subbase and R7247A Amplifier with R4140M. Requires Q7800L1001 Subbase and R7847A1009 or R7847B1007 Amplifier with RM7840M1017.

**FOOTNOTES:**

- ① Refer to Primary Cross-Reference section to select proper voltage, frequency, and timings.
- ② Replacement indicated is 120 Vac, 60 Hz. Identical control available with 120 Vac, 50 Hz.
- ③ Select R7847A1025, 1033 or R7847B1023, 1031 Amplifier.
- ④ See Modernization Wiring Information section.

**TABLE 2—RA890E CROSS REFERENCE**

OS Number	Volt. and Freq. (Hz)	Specifications		Alarm Contacts	Current RA890F Rplcmt. <sup>①</sup>	SERIES 7800 Replacement <sup>①②③④</sup>
		Timing (sec.)				
		Safety Switch	Flame Response			
1009	120,60	30	0.8		1338	RM7890A1015
1017	208,60	30	0.8		None	None
1025	240,60	30	0.8		1353	None
1033	120,50	30	0.8		1338	RM7890A1007
1041	220,50	30	0.8		None	None
1058	240,50	30	0.8		1353	None
1066	120,60	30	2-4		1346	RM7890A1015
1074	208,60	30	2-4		None	None
1082	240,60	30	2-4		1361	None
1090	120,50	30	2-4		1346	RM7890A1007
1108	220,50	30	2-4		None	None
1116	240,50	30	2-4		1361	None
1124	120,60	15	0.8		1270	RM7890A1015
1132	208,60	15	0.8		None	None
1140	240,60	15	0.8		1379	None
1157	120,50	15	0.8		1270	RM7890A1007
1165	220,50	15	0.8		1304	None
1173	240,50	15	0.8		1379	None
1181	120,50/60	15	2-4		1288	RM7890A1015 <sup>⑤</sup>
1199	208,50/60	15	2-4		1296	None
1207	240,50/60	15	2-4		1387	None
1215	120,50	15	2-4		1288	RM7890A1007
1223	220,50	15	2-4		1429	None
1231	240,50	15	2-4		1387	None
1249	120,50/60	30	0.8	N.O.	1338	RM7890A1015 <sup>⑤</sup>
1256	208,50/60	30	0.8	N.O.	None	None
1264	240,50/60	30	0.8	N.O.	1353	None
1272	220,50	30	0.8	N.O.	None	None
1280	120,50/60	30	2-4	N.O.	1346	RM7890A1015 <sup>⑤</sup>
1298	208,60	30	2-4	N.O.	None	None
1306	240,60	30	2-4	N.O.	1361	None
1314	120,50	30	2-4	N.O.	1346	RM7890A1007
1322	220,50	30	2-4	N.O.	None	None
1330	240,50	30	2-4	N.O.	1361	None
1348	120,50/60	15	0.8	N.O.	1270	RM7890A1015 <sup>⑤</sup>
1355	208,50/60	15	0.8	N.O.	None	None
1363	240,50/60	15	0.8	N.O.	1379	None
1371	240,50	15	0.8	N.O.	1379	None
1389	120,50/60	15	2-4	N.O.	1288	RM7890A1015 <sup>⑤</sup>
1397	208,50/60	15	2-4	N.O.	1296	None
1405	240,50/60	15	2-4	N.O.	1387	None
1415	120,60	30	0.8	N.C.	1338	RM7890A1015
1421	208,60	30	0.8	N.C.	None	None
1439	240,60	30	0.8	N.C.	1353	None
1447	120,60	30	2-4	N.C.	1346	RM7890A1015
1454	240,60	30	2-4	N.C.	1361	None
1462	120,50/60	15	0.8	N.C.	1270	RM7890A1015 <sup>⑤</sup>
1470	208,50/60	15	0.8	N.C.	None	None
1488	240,50/60	15	0.8	N.C.	1379	None
1496	120,50/60	15	2-4	N.C.	1288	RM7890A1015 <sup>⑤</sup>
1504	208,50/60	15	2-4	N.C.	1296	None
1512	240,50/60	15	2-4	N.C.	1387	None
1520	120,60	45	2-4	N.O.	None	RM7890A1015
1538	240,60	45	2-4	N.O.	None	None

TABLE 2—RA890E CROSS REFERENCE (continued)

OS Number	Specifications				Current RA890F Rplcmt. ①	SERIES 7800 Replacement ①②③④
	Volt. and Freq. (Hz)	Timing (sec.)		Alarm Contacts		
		Safety Switch	Flame Response			
1546	240,50	30	0.8	N.O.	1353	None
1553	208,50	30	0.8		None	None
1561	220,50	15	0.8	N.O.	1304	None
1579	220,50	15	2-4	N.C.	1429	None
1587	120,50	15	2-4	N.C.	1288	RM7890A1007
1595	240,50	15	2-4	N.C.	1387	None
1603	120,50/60	30	0.8	Spdt	1338	RM7B90A1015 <sup>⑤</sup>
1611	220,50	30	0.8	Spdt	None	None
1629	120,50/60	30	2-4	Spdt	1346	RM7890A1015 <sup>⑤</sup>
1637	240,50/60	30	2-4	Spdt	1361	None
1645	120,50	30	2-4	Spdt	1346	RM7890A1007
1652	220,50	30	2-4	Spdt	None	None
1660	240,50	30	2-4	Spdt	1361	None
1678	120,50/60	15	0.8	Spdt	1270	RM7890A1015 <sup>⑤</sup>
1686	208,50/60	15	0.8	Spdt	None	None
1694	240,50/60	15	0.8	Spdt	1379	None
1702	120,50/60	15	2-4	Spdt	1288	RM7890A1015 <sup>⑤</sup>
1710	208,50/60	15	2-4	Spdt	1296	None
1728	240,50/60	15	2-4	Spdt	1387	None
1736	208,50/60	30	0.8	Spdt	None	None
1744	240,50	15	2-4	Spdt	1387	None
1751	240,50/60	30	0.8	Spdt	1353	None
1769	220,50	15	2-4	Spdt	1429	None
1777	120,50	15	2-4	Spdt	1288	RM7890A1007
1785	220,50	15	2-4	N.O.	1429	None
1793	220,50	15	0.8	N.O.	1304	None
1801	240,50	15	2-4		1387	None
1819	220,50	15	2-4		1429	None
1827	120,50	15	2-4		1288	RM7890A1007
1835	220,50	30	2-4	⑦	None	None
1843	240,50	30	2-4	⑦	None	None
1850 <sup>⑥</sup>	240,50/60	30	0.8		None	None
1868 <sup>⑥</sup>	208,50/60	30	0.8		None	None
1876	220,50	15	0.8	Spdt	1304	None
1884	240,50/60	30	0.8	Spdt	1353	None
1892	100,50/60	15	0.8		None	None
1900	200,50/60	15	0.8		None	None
1918	120,50/60	15	0.8		1270	RM7890A1015 <sup>⑤</sup>
1926	120,50/60	15	2-4		1288	RM7890A1015 <sup>⑤</sup>
1934	120,50/60	15	0.8	Spdt	1270	RM7890A1015 <sup>⑤</sup>
1942	120,50/60	15	2-4	Spdt	1288	RM7890A1015 <sup>⑤</sup>
1959	100,50/60	15	2-4	Spdt	None	None
1967 <sup>⑥</sup>	220,50	30	2-4		None	None
1975 <sup>⑥</sup>	208,60	15	2-4	Spdt	None	None

FOOTNOTES:

- ① Spdt alarm contacts.
- ② Use Q7800F1004 Subbase with RM7890A,B controls.
- ③ Select proper amplifier; R7847A1025, R7847A1033 Rectification Amplifiers or R7847B1023, R7847B1031 AMPLI-CHECK™ Amplifiers.
- ④ C7012E,F Dynamic Self-Check, Ultraviolet Flame Detectors can be used with RM7890B1006,1014 controls. Use R7847C1005 Amplifier.
- ⑤ 120 Vac, 50 Hz control is RM7890A1007.
- ⑥ Fungus-proof.
- ⑦ Leadwires (made in Canada).

**TABLE 3—RA890F CROSS REFERENCE**

OS Number	Specifications				Current RA890F Rplcmt. <sup>⑤</sup>	SERIES 7800 Replacement <sup>⑤⑥⑦⑧⑨</sup>
	Voltage (50/60 Hz)	Timing (sec.)		Alarm Contacts		
		Safety Switch	Flame Response			
1007	120	30	0.8		1338	RM7890A1015
1015	120	30	3.0		1346	RM7890A1015
1023	120	15	0.8		1270	RM7890A1015
1031	120	15	3.0		1288	RM7890A1015
1049	120	15	0.8	Spdt	1270	RM7890A1015
1056	120.	15	3.0	Spdt	1288	RM7890A1015
1064	120	15	0.8	Spdt	1270	RM7890A1015
1072	120	15	3.0	Spdt	1288	RM7890A1015
1080	208	15	3.0	Spdt	1296	None
1098	220	15	0.8	Spdt	1304	None
1106	240	15	0.8		1379	None
1114	240	15	3.0		1387	None
1122	120	30	0.8	Spdt	1338	RM7890A1015
1130	120	30	3.0	Spdt	1346	RM7890A1015
1148	240	30	0.8	Spdt	1353	None
1155	240	30	3.0	Spdt	1361	None
1163	240	15	0.8	Spdt	1379	None
1171	240	15	3.0	Spdt	1387	None
1189	240	30	0.8		1353	None
1197	240	30	3.0		1361	None
1205	100	15	3.0	Spdt	None	None
1213	220	15	3.0	Spdt	1429	None
1221	240	15	3.0	Spdt	1387	None
1239	120	30	0.8		1338	RM7890A1015
1247	120	30	3.0		1346	RM7890A1015
1254	120	15	0.8		1270	RM7890A1015
1262	120	15	3.0		1288	RM7890A1015
1270	120	15	0.8	Spdt	1270	RM7890A1015
1288	120	15	3.0	Spdt	1288	RM7890A1015
1296	208	15	3.0	Spdt	1296	None
1304	220	15	0.8	Spdt	1304	None
1312	240	15	0.8		1379	None
1320	240	15	3.0		1387	None
1338	120	30	0.8	Spdt	1338	RM7890A1015
1346	120	30	3.0	Spdt	1346	RM7890A1015
1353	240	30	0.8	Spdt	1353	None
1361	240	30	3.0	Spdt	1361	None
1379	240	15	0.8	Spdt	1379	None
1387	240	15	3.0	Spdt	1387	None
1395	240	30	0.8		1353	None
1403	240	30	3.0		1361	None
1411	100	15	3.0	Spdt	None	None
1429	220	15	3.0	Spdt	1429	None
1437	120	15	3.0	Spdt	1288	RM7890A1015
1445	240	15	3.0	Spdt	1387	None
1452	208	15	0.8	Spdt	None	None
1460	100	15	0.8	Spdt	None	None
1478 <sup>①</sup>	120	15	0.8	Spdt	1478	RM7890A1015
1486	120	30	0.8		1338	RM7890A1015
1494	120	30	3.0		1346	RM7890A1015
1502	120	15	0.8		1270	RM7890A1015
1510	120	15	3.0		1288	RM7890A1015
1528	120	15	0.8	Spdt	1270	RM7890A1015
1536	240	15	0.8		1379	None

TABLE 3—RA890F CROSS REFERENCE (continued)

Specifications					Current RA890F Rplcmt. <sup>⑤</sup>	SERIES 7800 Replacement <sup>⑤⑥⑦⑧⑨</sup>
OS Number	Voltage (50/60 Hz)	Timing (sec.)		Alarm Contacts		
		Safety Switch	Flame Response			
1544	240	15	3.0		1387	None
1551	120	30	0.8	Spdt	1338	RM7890A1015
1569	120	30	3.0	Spdt	1346	RM7890A1015
1577	240	30	0.8	Spdt	1353	None
1585	240	30	3.0	Spdt	1361	None
1593	240	15	0.8	Spdt	1379	None
1601	240	30	0.8		1353	None
1619	240	30	3.0		1361	None
1627 <sup>①</sup>	120	15	0.8		1478	RM7890A1015
1635 <sup>②</sup>	120	15	0.8	Spdt	None	None
1643 <sup>②</sup>	120	15	3.0		None	None
1650 <sup>②</sup>	220	15	0.8	Spdt	None	None
1668 <sup>③</sup>	220	10	0.8	Spdt	None	None
1676 <sup>④</sup>	120	15	0.8	Spdt	None	None
1692 <sup>⑩</sup>	220	15	0.8	Spdt	1692 <sup>⑩</sup>	None
1700 <sup>⑩</sup>	120	30	0.8	Spdt	1700 <sup>⑩</sup>	RM7890A1015
1718 <sup>⑩</sup>	120	30	3.0	Spdt	1718 <sup>⑩</sup>	RM7890A1015
1726 <sup>⑩</sup>	240	30	3.0	Spdt	1726 <sup>⑩</sup>	None
1734 <sup>⑪</sup>	120	15	3.0	Spdt	1734 <sup>⑪</sup>	None

FOOTNOTES:

- ① Fast response.
- ② Tamper resistant cover.
- ③ 15 second delayed pull-in.
- ④ Approved for -40° F (-40° C) applications.
- ⑤ Spdt alarm contacts.
- ⑥ 120 Vac, 60 HZ replacement indicated: RM7890A1007 is 120 Vac, 50 Hz replacement.
- ⑦ Use Q7800F1004 Subbase.
- ⑧ Select proper amplifier; R7847A1025, R7847A1033 Rectification Amplifiers or R7847B1023, R7847B1031 AMPLI-CHECK™ Amplifiers.
- ⑨ C7012E,F Dynamic Self-Check, Ultraviolet Flame Detectors can be used with RM7890B1006,1014 controls. Use R7847C1005 Amplifier.
- ⑩ Honeywell Mexico only.
- ⑪ North American Special. Available from proprietary OEM only.

**TABLE 4—RA890G CROSS REFERENCE.**

RA890G-OS Number to be Replaced	Specifications				Current RA890G Rplcmt. ②	SERIES 7800 Replacement ②③④⑤⑥
	Voltage (50/60)	Timing (sec.)		Alarm Contacts		
		Safety Switch	FFRT			
1005	120	15	0.8		1229	RM7890A1015
1013	120	15	0.8	Spdt	1229	RM7890A1015
1021	240	15	0.8		1294	None
1039	220	15	0.8	Spdt	1245	None
1047	120	15	3.0		1260	RM7890A1015
1054	120	15	3.0	Spdt	1260	RM7890A1015
1062	208	15	3.0	Spdt	None	None
1070	120	15	0.8		1229	RM7890A1015
1088	120	15	0.8	Spdt	1229	RM7890A1015
1096	240	15	0.8		1294	None
1104	220	15	0.8	Spdt	1245	None
1112	120	15	3.0		1260	RM7890A1015
1120	120	15	3.0	Spdt	1260	RM7890A1015
1138	208	15	3.0	Spdt	None	None
1146	240	15	3.0	Spdt	1286	None
1153	120	15	0.8		1229	RM7890A1015
1161	120	15	0.8	Spdt	1229	RM7890A1015
1179	120	15	3.0		1260	RM7890A1015
1187	120	15	3.0	Spdt	1260	RM7890A1015
1195	240	15	0.8	Spdt	1294	None
1203	220	15	3.0	Spdt	1302	None
1211	120	15	0.8		1211	RM7890A1015
1229	120	15	0.8	Spdt	1229	RM7890A1015
1237	240	15	0.8		1294	None
1245	220	15	0.8	Spdt	1245	None
1252	120	15	3.0		1252	RM7890A1015
1260	120	15	3.0	Spdt	1260	RM7890A1015
1278	208	15	3.0	Spdt	None	None
1286	240	15	3.0	Spdt	1286	None
1294	240	15	0.8	Spdt	1294	None
1302	220	15	3.0	Spdt	1302	None
1310①	120	15	0.8	Spdt	1310①	RM7890A1015
1328⑦	120	15	0.8	Spdt	1328⑦	RM7890A1015
1336⑦	120	15	3.0	Spdt	1336⑦	RM7890A1015
1344⑧	120	15	3.0	Spdt	1344⑧	None

**RA890G FOOTNOTES:**

- ① Approved for -40° F (-40° C) applications. Two spdt alarm contacts.
- ② Spdt alarm contacts.
- ③ 120 Vac, 60 Hz replacement indicated. RM7890A1007 is 120 Vac, 50 Hz replacement.
- ④ Use Q7800F1004 subbase.
- ⑤ Select proper amplifier; R7849A1015, R7849A1023 or R7849B1013, B7849B1021 AMPLI-CHECK™.
- ⑥ C7012E,F Dynamic Self-Check, Ultraviolet Flame Detectors can be used with RM7890B1006,1014 controls. Use R7847C1005 Amplifier.
- ⑦ Honeywell Mexico only.
- ⑧ North American Special. Available from proprietary OEM only.



TABLE 5—RA890H,J,K DYNAMIC SELF-CHECK CROSS REFERENCE

Specifications					Current Rplcmt. <sup>①⑥⑦</sup>	SERIES 7800 Replacement <sup>①②③④⑤</sup>
RA890H,J,K OS Number to be Replaced <sup>⑥⑦</sup>	Voltage (50/60)	Timings		Alarm Contacts		
		Safety Switch	FFRT			
RA890H1003	120	15	2.5	Spdt	H1052	RM7890A1015
RA890H1011	208	15	2.5	Spdt	None	None
RA890H1029	240	15	2.5	Spdt	None	None
RA890H1037	100	15	2.5	Spdt	None	None
RA890H1045	220	15	2.5	Spdt	None	None
RA890H1052	120	15	2.5	Spdt	H1052	RM7890A1015
RA890J1008	120	15	2.5	Spdt	J1008	None
RA890J1016	120	15	2.5	Spdt	J1008	None
RA890J1024	208	15	2.5	Spdt	None	None
RA890J1032	240	15	2.5	Spdt	None	None
RA890K1006	120	15	2.5	Spdt	H1052	RM7890A1015

FOOTNOTES:

- ① Spdt alarm contacts.
- ② 120 Vac, 60 Hz replacement indicated. RM7890A1007 is 120 Vac, 50 Hz replacement.
- ③ Use Q7800F1004 Subbase.
- ④ Use R7847B1023, R7847B1031 AMPLI-CHECK™.
- ⑤ C7012E,F Dynamic Self-Check, Ultraviolet Flame Detectors can be used with RM7890B1006,1014 controls. Use R7847C1005 Amplifier.
- ⑥ Tamper-resistant cover.
- ⑦ Cutoff on flame failure.
- ⑧ Continuous pilot applications.
- ⑨ No safe-start check.

# Replacing the R190C in a W124 Protectorelay Control with an RA890H

---

## FOR ALL SYSTEMS EXCEPT AUTO-RELIGHT

**IMPORTANT:** *If this device is not to be used in a W124, discard these Instructions.*

To replace the R190C Electronic Relay with the RA890H Protectorelay Primary Control, follow these instructions:



### **CAUTION**

---

1. Installer must be a trained, experienced flame safeguard control service technician.
  2. Disconnect power supply before beginning installation to prevent electrical shock and equipment damage.
  3. Perform all required checkout tests after installation is complete.
- 

## **CHANGE WIRING CONNECTIONS ON W124 TERMINAL PANEL**

Make the following changes in the external wiring to the W124 terminal strip:

1. Remove wire (if there is one) from terminal R and wrap the bare end with electrical tape for insulation.
2. Remove wire from terminal 7 and connect to terminal R.
3. Remove wire from terminal 8 and connect to terminal 7.
4. Securely tighten all screw terminals.

## REMOVE R190C

1. Loosen the ten mounting screws.
2. Remove the R190C from the subbase.

## MOUNT RA890H

1. Loosen thumbscrew and remove cover.

**IMPORTANT:** *Do not remove the protective barrier that shields the printed circuit.*

2. Position RA890H over the subbase.
3. Start all ten mounting screws and tighten uniformly.

**NOTE:** These screws complete electrical circuits and also hold the RAS90H to the subbase.



### **CAUTION**

---

Do not overtighten the mounting screws because damage to the circuit board can result. Maximum recommended torque is 15 lb.-in.

---

4. Replace cover and securely tighten thumbscrew.

Refer to the W124 manual (form 95-1627) for external wiring diagrams and additional instructions. Refer to the RA890H Instructions (form 60-2074) for additional specifications.

# Replacing a W124 or ID051 Flame Safeguard Panel with an R4138C or D

---



## **CAUTION**

Disconnect power supply before making wiring connections to prevent electrical shock or equipment damage.

---

NOTE: An ID051 is a W124 with an integral START-STOP station.

### **TO REPLACE A W124 OR ID051 PANEL WITH AN R4138C OR D—**

1. Remove and carefully mark the old leadwires.
2. Remove the W124 or ID051 chassis and case (if installed).

3. Install a Q477A Subbase (for mounting in a customer's cabinet), or a Q478A Cabinet (for flush or surface mounting). Refer to the installation instructions for the R4138C or D (form 60-2368).

4. Rewire the installation as shown in the typical wiring diagram below, or refer to the installation instructions provided by the burner manufacturer and to those in the R4138C,D instructions (form 60-2368). Before starting, carefully review the footnotes for the wiring diagram.

5. Install the R4138 (refer to form 60-2368).

For additional instructions and specifications, refer to the R4138C,D instructions, form 60-2368.

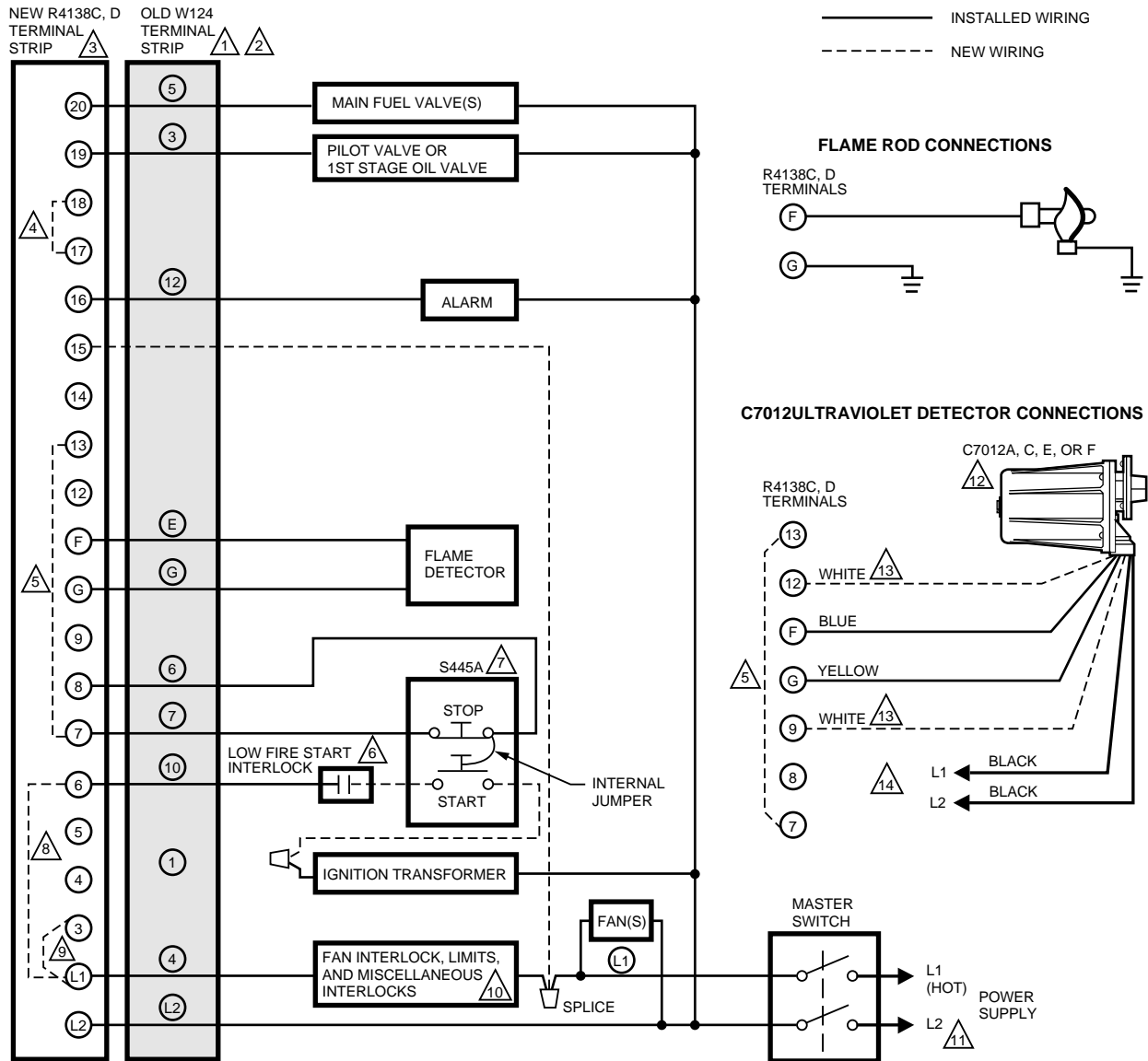

- 1 OLD PANEL TERMINALS ARE SHOWN FOR REFERENCE ONLY. THE EXISTING WIRING TO BE REMOVED FROM THE PANEL TERMINALS IS SHOWN BY SOLID LINES (—), AND THE NEW WIRING IS SHOWN BY DASHED LINES (---). USE ALL NEC CLASS 1 WIRING.
- 2 REMOVE AND DISCARD ALL JUMPERS USED ON THE W124 OR ID051.
- 3 INSTALL A NEW Q477A SUBBASE, Q478A CABINET OR FSP1225 (NEMA 4) ENCLOSURE. REMOVE AND DISCARD THE OLD CHASSIS AND CASE.
- 4 IF USING A HIGH FIRE INTERLOCK, REFER TO WIRING DIAGRAMS IN THE INSTRUCTION SHEET FOR THE R4138C, D (FORM 60-2368). OTHERWISE, INSTALL A JUMPER BETWEEN TERMINALS 17 AND 18.
- 5 IF USING A C7012E OR F PURPLE PEEPER ULTRAVIOLET FLAME DETECTOR (WITH SELF-CHECKING SHUTTER), INSTALL A JUMPER BETWEEN TERMINALS 13 AND 7.
- 6 IF A LOW FIRE START INTERLOCK IS NOT USED, CONNECT THE START SWITCH DIRECTLY TO TERMINAL 6.
- 7 FOR A Q478A1031 CABINET WITH A FACTORY INSTALLED START-STOP SWITCH, MAKE SURE THE SWITCH IS WIRED AS SHOWN; REWIRE IF NECESSARY. FOR REMOTE OPERATION, USE AN S445A START-STATION, OR EQUIVALENT WITH AN INTERNAL JUMPER AS SHOWN.

- 8 IF AN S427D PURGE TIMER IS NOT USED, INSTALL A JUMPER BETWEEN TERMINALS L1 AND 6.
- 9 INSTALL A JUMPER BETWEEN TERMINALS L1 AND 3.
- 10 THESE INTERLOCKS AND LIMITS MUST BE RATED TO CARRY AND BREAK CURRENT TO THE IGNITION TRANSFORMER, PILOT VALVE (OR 1ST STAGE OIL VALVE), AND MAIN FUEL VALVE(S) SIMULTANEOUSLY.
- 11 PROVIDE DISCONNECT MEANS AND OVERLOAD PROTECTION AS REQUIRED. POWER SUPPLY MUST MATCH THE VOLTAGE AND FREQUENCY RATING OF THE R4138.
- 12 TWO C7012 PURPLE PEEPER ULTRAVIOLET FLAME DETECTORS MAY BE WIRED IN PARALLEL TO THE SAME TERMINALS AS SHOWN, EXCEPT A C7012E NOT RATED FOR 120 VOLTS. ONLY ONE C7012E CAN BE CONNECTED AS SHOWN IF THE R4138 POWER SUPPLY IS NOT 120 VOLTS.
- 13 WHITE SHUTTER LEADWIRES ARE ONLY ON THE C7012E OR F (WITH SELF-CHECKING SHUTTER).
- 14 VOLTAGE AND FREQUENCY RATING OF THE C7012 MUST MATCH THE RATING OF THE R4138.

M6922

**TABLE 6—R485 PRIMARY RELAY CROSS REFERENCE**

Device To Be Replaced	Current Replacement	SERIES 7800 Replacement (2) (3)	Functions of Device To Be Replaced				Comments
			Voltage/Frequency	FFRT (Sec)	Solid State	Flame Detector Type	
R485A1001	R485B1000	RM7885A1015 (1)	120/50,60	2-4	No	Flame rod, rectifying photocell, C7012A,C	Mounted on Q267A base (6)
R485A1019	R485B1018	None	240/50,60	2-4	No	Same as above	Mounted on Q267A base (6)
R485A1027	R485A1026	None	208/50,60	2-4	No	Same as above	Mounted on Q267A base (6)
R485A1035	R485B1000	RM7885A1007	120/50	2-4	No	Same as above	International model
R485A1043	R485B1000 (5)	RM7885A1015 (1)	120/50,60	0.8	No	Same as above	International model
R485A1050	R485B1018 (5)	None	240/60	0.8	No	Same as above	International model
R485A1068	R485B1000 (4)	RM7885A1015 (1) (4)	120/60	2-4	No	Same as above	Fungus-proof
R485A1076	R485B1018 (4)	None	240/50,60	2-4	No	Same as above	Fungus-proof. Includes Q267A mounting (6)
R485B1000	R485B1000	RM7885A1015 (1)	120/50,60	3.0	Yes	Same as above	Mounted on Q267A base (6)
R485B1018	R485B1018	None	240/50,60	3.0	Yes	Same as above	Mounted on Q267A base (6)
R485B1026	R485B1026	None	208/50,60	3.0	Yes	Same as above	Mounted on Q267A base (6)
R485B1034	R485B1018 (5)	None	240/50,60	0.8	Yes	Same as above	Mounted on Q267A base (6)
R485B1042	R485B1000 (5)	RM7885A1015 (1)	120/50,60	0.8	Yes	Same as above	Mounted on Q267A base (6)
R485X1005	R485B1018	None	240/50	2-4	No	Same as above	International model
R485X1013	R485B1026	None	208/50	2-4	No	Same as above	With Q267A. (6) International model
R485X1021	None	None	220/50	2-4	No	Same as above	International model
R485X1039	R485B1000	RM7885A1007	120/50	2-4	No	Same as above	International model
R485X1047	None	None	220/50	0.8	No	Same as above	Mounted on Q267A base (6)
R485X1054	None	None	220/50,60	3.0	Yes	Same as above	
R485X1062	None	None	220/50,6	0.8	Yes	Same as above	

**FOOTNOTES:**

(1) Replacement indicated is 120 Vac, 60 Hz. R7885A1007 is 120 Vac, 50 Hz.

(2) Use Q7800A1005 (panel mount) or Q7800A1003 (burner mount) subbase.

(3) Select proper plug-in amplifier.

(4) Contact your Honeywell Home and Building Control Sales Office for fungus-proofed devices.

(5) Replacement has 3 second FFRT.

(6) No longer available.

TABLE 7—R4075 CROSS REFERENCE

Device To Be Replaced	Current Replacement <sup>(1)</sup> (2)(3)	SERIES 7800 Replacement <sup>(5)</sup> (13)(14)	Function of Device To Be Replaced							Comments
			Voltage	Frequency (Hz)	Flame Sensor Type <sup>(4)</sup>	Terminal Monitor 2K Relay Voltage	Flame Signal Jack	Power Failure Override	Continuous Pilot Application Circuit Provided	
R4075A1009	NONE	NONE	120/208/240	50/60	rectification	yes	no	no	no	With Q442A <sup>(9)</sup> flush mount cabinet. With Q294A <sup>(9)</sup> surface mount cabinet.
R4075A1017	NONE	NONE	120/208/240	50/60	rectification	yes	no	no	no	With Q295A mounting plate.
R4075A1025	NONE	NONE	120/208/240	50/60	rectification	yes	no	no	no	With Q442A <sup>(9)</sup> flush mount cabinet.
R4075A1033	NONE	NONE	120/208/240	50/60	rectification	yes	no	no	no	
R4075A1041	NONE	NONE	110/208/220	50	rectification	yes	no	no	no	
R4075A1058	NONE	NONE	110/208/220	50	rectification	yes	no	no	no	
R4075B1007	R4075C1005 <sup>(7)</sup>	RM7885A1015 <sup>(6)</sup>	120/208/240	50/60	rectification	yes	no	no	no	
R4075B1015	R4075C1005 <sup>(7)</sup>	RM7885A1015 <sup>(6)</sup>	120/208/240	50/60	rectification	yes	no	no	no	
R4075B1023	R4075C1005 <sup>(8)</sup>	RM7885A1007 <sup>(13)</sup>	110/220	50	rectification	yes	no	no	no	
R4075B1031	R4075C1005 <sup>(7)</sup>	RM7885A1015 <sup>(6)</sup>	120/208/240	50/60	rectification	yes	yes	no	no	
R4075B1049	R4075C1005 <sup>(8)</sup>	RM7885A1007 <sup>(13)</sup>	110/220	50	rectification	yes	yes	no	no	
R4075B1056	R4075C1005	RM7885A1015 <sup>(6)</sup>	120	50/60	rectification <sup>(12)</sup>	yes	yes	no	no	
R4075C1005	R4075C1005	RM7885A1015 <sup>(6)</sup>	120	50/60	rectification <sup>(12)</sup>	no	yes	no	yes	
R4075C1013	R4075C1013	NONE	208	50/60	rectification <sup>(12)</sup>	no	yes	no	yes	
R4075C1021	R4075C1021	NONE	220	50	rectification <sup>(12)</sup>	no	yes	no	yes	
R4075C1039	R4075C1039	NONE	240	50/60	rectification <sup>(12)</sup>	no	yes	no	yes	
R4075D1003	R4075D1003	RM7885A1015 <sup>(6)</sup>	120	50/60	rectification <sup>(12)</sup>	no	yes	yes	yes	
R4075E1000	R4075E1000	NONE	120	50/60	rectification <sup>(12)</sup>	no	yes	no	yes	<sup>(10)</sup>
R4075E1018	NONE	NONE	220	50	rectification <sup>(12)</sup>	no	yes	no	yes	<sup>(11)</sup>

FOOTNOTES:

- ① When replacing an R4075A with an R4075C, order the R7247B1003 AMPLI-CHECK™ Amplifier.
- ② C7012A,C Flame Detectors can be upgraded to C7012E,F Dynamic Self-Check Ultraviolet Flame Detectors. Use R7247C1001 Amplifier.
- ③ When replacing a R4075B with an R4075C, order the R7247B1003 AMPLI-CHECK® Amplifier.
- ④ Flame rods; C7012A,C Ultraviolet Flame Detectors; C7010A, C7013A, C7014A Visible Flame Detectors.
- ⑤ Use universal Q7800A1005 (panel mount) or Q7800B1003 (metal burner mount) subbase.
- ⑥ 120 Vac, 60 Hz replacement indicated. 120 Vac, 50 Hz is RM7800A1007.
- ⑦ 208 Vac, 50-60 Hz replacement is R4075C1013. 240 Vac, 50-60 Hz replacement is

- ⑧ R4075C1039.
- ⑨ 220 Vac, 50 Hz replacement is R4075C1039.
- ⑩ No longer available.
- ⑪ Equivalent to two independent R4075C1005 on one R4075 Chassis.
- ⑫ Equivalent to two independent R4075C1021 on one R4075 Chassis.  
When replacing R4075 Chassis, use existing sensor and amplifier. For new installations, refer to R4075 C,D Specification (form 60-2367) or Honeywell TRADELINE® Catalog for listing of R4075C,D,E Amplifier and Sensors.
- ⑬ 120 Vac only.
- ⑭ Select proper amplifier.

**TABLE 8—HONEYWELL R4138 CROSS REFERENCE**

Device To Be Replaced	Current Replacement <sup>①</sup> <sup>③</sup>	7800 SERIES Replacement <sup>④</sup> <sup>⑤</sup> <sup>⑥</sup> <sup>⑧</sup>	Functions of Device to be Replaced						Pilot Link Continuous Application	Safety Switch (Secs)	Comments
			Voltage (Vac)	Frequency (Hz)	Flame Type	Terminal To Monitor Voltage	Power Override	Terminal To Monitor Voltage			
R4138A1004	R4138C1018	RM7838A1014	120/208/240	50/60	Flame rods, visible photocells C7012A,C,E,F	No	No	No	15		
R4138A1012	R4138C1018	RM7838A1014 <sup>⑦</sup>	120/208/240	50/60	Same as above	Yes	No	No	15		
R4138A1020	R4138C1018	RM7838A1014 <sup>⑦</sup>	120	50/60	Same as above	No	No	No	15		
R4138A1038	R4138C1018	RM7838A1014 <sup>⑦</sup>	120	50/60	Same as above	Yes	No	No	15		
R4138B1002	R4138D1016	RM7838A1014 <sup>⑦</sup>	120/208/240	50/60	Same as above	No	Yes	No	15		
R4138B1010	R4138D1016	RM7838A1014 <sup>⑦</sup>	120/208/240	50/60	Same as above	No	Yes	No	30		
R4138B1028	R4138D1016	RM7838A1014 <sup>⑦</sup>	120	50/60	Same as above	No	Yes	No	15		
R4138C1000	R4138C1018 <sup>②</sup>	RM7838A1014 <sup>⑦</sup>	120	50/60	Same as above	No	No	Yes	15	Neon lights; never produced	
R4138C1018	R4138C1018	RM7838A1014	120	50/60	Same as above	No	No	Yes	15	Incandescent lights	
R4138C1026	None	None	240	50/60	Same as above	No	No	Yes	15	Incandescent lights	
R4138C1034	None	None	220	50	Same as above	No	No	Yes	15	Incandescent lights	
R4138D1008	R4138D1016 <sup>②</sup>	RM7838A1014 <sup>⑦</sup>	120	50/60	Same as above	No	Yes	Yes	15	Neon lights; never produced	
R4138D1016	R4138D1016	RM7838A1014 <sup>⑦</sup>	120	50/60	Same as above	No	Yes	Yes	15	Incandescent lights	
R4138X1001	None	None	120/200/230	50	Same as above	No	No	No	15		

**FOOTNOTES:**

- ① When replacing a R4138A,B with an R4138C,D, separately order the R7247B1003 AMPLI-CHECK™ (for flame rod, rectifying photocell and C7012A,C Flame Detectors) or the R7247C1001 Amplifier (for Dynamic Self-Check Ultraviolet Flame Detectors and C7012E,F).
- ② When replacing the R4138C,D Chassis, use the existing flame detector and amplifier. For new installations, refer to the R4138C,D Specifications (form 60-2368), or the Honeywell Tradeline® Catalog for a listing of compatible flame detectors and associated amplifiers.
- ③ 120 Vac only.
- ④ Replacements indicated are 120 Vac, 60 Hz. Identical 120 Vac, 50 Hz models are available.
- ⑤ Use the Q7800A1005 (panel mount) or the Q7800B1003 (burner mount) universal subbase.
- ⑥ Select proper amplifier.
- ⑦ Continuous pilot option.
- ⑧ 4 or 10 second PFEP.



TABLE 9—HONEYWELL R4795 CROSS REFERENCE

Device To Be Replaced	Current Replacement ①	7800 SERIES Replacement ③④⑤⑥⑨⑩⑪	Functions of Device To Be Replaced				Comments
			SPDT Alarm Contacts	Safety Switch Timing (Secs)	Voltage (Vac)	Frequency (Hz)	
R4795A1008	R4795A1016	RM7895A1014 RM7895B1013⑦ RM7895C1012⑧ RM7895D1011⑦⑧	No	15	120	50/60	—
R4795A1016	R4795A1016	RM7895A1014 RM7895B1013⑦ RM7895C1012⑧ RM7895D1011⑦⑧	Yes	15	120	50/60	—
R4795A1024	R4795A1016	RM7895A1014 RM7895B1013⑦ RM7895C1012 RM7895D1011	No	15	120	50/60	with R7289A1004 and ST71A1018
R4795A1032	R4795A1016	RM7895A1014 RM7895B1013⑦ RM7895C1012⑧ RM7895A1011⑦⑧	Yes	15	120	50/60	with R7289A1004 and ST71A1018
R4795A1040	R4795A1040	None	Yes	15	220	50/60	—
R4795A1057	None	None	Yes	15	240	50/60	—
R4795A1065	R4795A1016	RM7895A1014 RM7895B1013⑦ RM7895C1012⑧ RM7895A1011⑦⑧	No	15	120	50/60	With R7289A1004 and ST71A1026
R4795A1073	R4795A1016	RM7895A1014 RM7895B1013⑦ RM7895C1012⑧ RM7895A1011⑦⑧	Yes	15	120	50/60	With R7289A1004 and ST71A1026
R4795A1081	R4796A1081	RM7895A1014 RM7895B1013⑦ RM7895C1012⑧ RM7895D1011⑦⑧	Yes	15	120	60	-40° F [-40° C] rating. Use with R7289A1029 (rectification) or R7290A1027 (UV) amplifiers.

(continued)

TABLE 9—HONEYWELL R4795 CROSS REFERENCE (continued)

Device To Be Replaced	Current Replacement <sup>①</sup>	7800 SERIES Replacement (3) (4) (5) (6) (9) (10) (11)	Functions of Device To Be Replaced				Comments
			SPDF Alarm Contacts	Safety Switch Timing (Secs)	Voltage (Vac)	Frequency (Hz)	
R4795A1099	R4795A1099	None	Yes	15	100	50/60	—
R4795A1107	R4795A1107	None	Yes	15	200	50/60	—
R4795C1004	R4795A1016 <sup>②</sup>	RM7895A1014 RM7895B1013 RM7895C1012 RM7895D1011	No	15	120	50/60	Continuous pilot application. 30 sec prepurge, 3 sec FFRT. Use Q267A Subbase.
R4795D1002	R4795D1002	RM7895A1014 RM7895B1013 <sup>⑦</sup> RM7895C1012 <sup>⑧</sup> RM7895D1011 <sup>⑦</sup> <sup>⑧</sup>	Yes	15	120	50/60	—
R4795D1010	R4795A1002	RM7895A1014 RM7895B1013 <sup>⑦</sup> RM7895C1012 <sup>⑧</sup> RM7895D1011 <sup>⑦</sup> <sup>⑧</sup>	No	15	120	50/60	—
R4795D1028	None	None	Yes	15	220	50/60	—
R4795D1036	None	None	Yes	15	240	50/60	—
R4795D1044	None	None	Yes	15	100	50/60	—
R4795D1051	R4795D1051	RM7895A1014 RM7895B1013 <sup>⑦</sup> RM7895C1012 <sup>⑧</sup> RM7895D1011 <sup>⑦</sup> <sup>⑧</sup>	Yes	15	120	60	-40° F [-40° C] rating. Use with R7289A1020 (rectification) or R7290A1027 (UV) Amplifiers.
R4795D1069	R4795D1069	None	Yes	15	200	50/60	—

FOOTNOTES:

- ① Use existing purge timer and amplifier.
- ② Where pilot flame is in contact with a flame rod during the "OFF" cycle, use a switching relay powered by R4795A terminal 3. Connect a normally open contact of the switching relay in series with the flame rod "F" lead and R4795A terminal "E."
- ③ Replacement indicated is 120 Vac, 60 Hz. Identical 120 Vac, 50 Hz available.
- ④ Use Q7800A,B Subbase.
- ⑤ Select proper amplifier.
- ⑥ Air-flow proven.
- ⑦ Air-flow switch check (AFSC).
- ⑧ Delayed main valve.
- ⑨ Can be used with C7012E, F Dynamic Self-Check Ultraviolet Flame Detectors. Use R7847C1005 Amplifier.
- ⑩ 4 or 10 second PFEP.
- ⑪ ST7800A Plug-in Purge Timer required.

**TABLE 10—HONEYWELL R7023 CROSS REFERENCE**

Device to be Replaced	Current Replacement	Series 7800 Replacement (1)(2)(3)(4)	Functions of Devices to be Replaced				Comments
			Voltage/Frequency	FFRT (sec)	Solid State	Flame Detector Type (4)	
R7023A1005	R7023B1003	RM7823A1016	120/50, 60	2-4	no	Flame rod, rectifying photocell, C7012A,C	International model.
R7023A1013	None	None	208/50, 60	2-4	no		
R7023A1021	R7023B1052	None	220/50	2-4	no		
R7023A1039	R7023B1011	None	240/50, 60	2-4	no		
R7023A1047	R7023B1003(5)	RM7823A1016	120/50, 60	0.8	no		
R7023A1054	None	None	208/50, 60	0.8	no		
R7023A1062	R7023B1052(5)	None	220/50	0.8	no		
R7023A1070	R7023B1037	None	240/50, 60	0.8	no		
R7023B1003	R7023B1003	RM7823A1016	120/50, 60	3.0	yes		
R7023B1011	R7023B1011	None	240.50, 60	3.0	yes		
R7023B1029	None	None	208/50, 60	3.0	yes		
R7023B1037	R7023B1037	None	240/50, 60	0.8	yes		
R7023B1045	R7023B1003(5)	RM7823A1016	120/50, 60	0.8	yes		
R7023B1052	R7023B1052	None	220/50, 60	3.0	yes		International model.
R7023B1060	R7023B1052(5)	NoneE	220/ 50, 60	0.8	yes		International model.
R7023C1001	R7023C1001	RM7823A1016	120/50, 60	3.0	yes	UV C7027A, C7035A, C7044A	
R7023C1019	R7023C1019	RM7823A1016	120/50, 60	0.8	yes		
R7023C1027	R7023C1027	None	220/50, 60	0.8	yes		International model.
R7023C1035	R7023C1035	None	220/50, 60	3.0	yes		International model.
R7023C1043	R7023C1050(6)	None	240/50, 60	3.0	yes		
R7023C1050	R7023C1050	None	240/50, 60	0.8	yes		
R7023C1068	None	RM7823A1016	120/60	3.0	yes		Rated at -40 C (-40 C)
R7023X1002	None	None	120/25	2-4	no	Flame rod, rectifying photocell, C7012A,C	
R7023X1010	None	None	240/25	2-4	no		International model
R7023X1028	R7023B1052	None	220/50	2-4	no		International model.
R7023X1036	R7023B1052(5)	None	220/50	0.8	no		International model.
R7023X1044	R7023B1052	None	220/50, 60	3.0	yes		International model.
R7023X1051	R7023B1052(5)	None	220/50, 60	0.8	yes		International model.
R7023X1069	R7023B1052(5)(7)	None	220/50, 60	0.8	no		Fungus-proof. International model.
R7023X1077	None	None	100/50, 60	0.8	yes		International model.
R7023X1085	R7023B1052(5)(7)	None	220/50, 60	0.8	yes		Fungus-proof. International model.
R7023X1093	R7023C1027	None	220/50, 60	0.8	yes	UV C7027A, C7035A, C7044A	International model.

(1) Replacement indicated is 120 Vac, 60 Hz. 120 Vac, 50 Hz replacement is RM7823A1008.

(2) Use Q7800A1005 (panel mount) or Q7800B1003 (burner mount) subbase.

(3) Select appropriate amplifier for 0.8 or 3.0 sec FFRT.

(4) RM7823A controls can be used with C7012E,F Dynamic Self-Check, Ultraviolet Flame Detectors. Use R7847C1005 Amplifier (3 sec FFRT).

(5) Replacement has 3 second FFRT. Check application concerning the effect of the longer FFRT.

(6) Replacement has 0.8 second FFRT. Check application concerning the effect of a shorter FFRT.

(7) Contact your Honeywell Home and Building Control Sales Office regarding fungus-proofing.

**TABLE 11—HONEYWELL R7795 CROSS-REFERENCE**  
FUNCTIONS OF DEVICE TO BE REPLACED

Device To Be Replaced	Current Replacement	7800 SERIES Replacement	Voltage (Vac)	Frequency (Hz)	INTM Pilot	INTR Pilot	Run/ Test SWITCH	Airflow Switch Check (AFSC)	PFEF	Delayed Main Valve	Flame Detector Type	Safety Switch Timing (Sec)	Comments
R7795A1001	R7795A1001	RM7895A1014	120	50/60	x				4,10		Ultraviolet	15	Use with C7027A,C7035A, C7044A Flame Detectors.
R7795A1027	R7795A1027	None	120	50/60	x				4,10		Ultraviolet	15	Proprietary to Fulton Boiler.
R7795B1009	R7795B1009	RM7895A1014	120	50/60	x				4,10		Rectification	15	Use with flame rods, photocell, C7012A,C Flame Detectors.
R7795B1017	R7795B1017	RM7895A1014	120	50/60	x				4,10		Rectification	15	With remote reset cover, flame rod, photocell, C7012A,C Flame Detectors.
R7795B1025	R7795B1025	None	120	50/60	x				4,10		Rectification	15	Proprietary to Fulton Boiler.
R7795C1007	R7795C1007	RM7895C1012	120	50/60		x	x		4,10	x	Ultraviolet	15	Use with C7027A,C7035A, C7044A Flame Detectors.
R7795C1015	R7795C1015	None	120	50/60		x	x		4,10	x	Ultraviolet	15	Proprietary to Cleaver Brooks. Permanent nonrecycle.
R7795D1005	R7795D1005	RM7895C1012	120	50/60		x	x		4,10	x	Rectification	15	Use with flame rod, photocell, C7012A,C Flame Detectors.
R7795E1002	R7795E1002	RM7895B1013	120	50/60	x			x	4,10		Ultraviolet	15	Use with C7027A,C7035A, C7044A Flame Detectors.
R7795F1000	R7795F1000	RM7895B1013	120	50/60	x			x	4,10		Rectification	15	Use with flame rod, photocell, C7012A,C Flame Detectors.
R7795G1008	R7795G1008	RM7895D1011	120	50/60		x	x	x	4,10	x	Ultraviolet	15	Use with C7027A,C7035A, C7044A Flame Detectors.
R7795H1006	R7795H1006	RM7895D1011	120	50/60		x	x	x	4,10	x	Rectification	15	Use with flame rod, photocell, C7012A,C Flame Detectors.

**FOOTNOTES:**

- ① Replacement indicated is 120 Vac, 60 Hz. Identical model available with 120 Vac, 50 Hz.
- ② Use Q7800G1002 Subbase.
- ③ Select proper amplifier.
- ④ Select proper ST795A Plug-in Purge Timer.
- ⑤ Select proper ST7800A Plug-in Purge Timer.
- ⑥ Alarm contacts.
- ⑦ Field selectable recycle or lockout on flame failure.
- ⑧ Available from Proprietary OEM only.
- ⑨ Can be used with C7012E,F Dynamic Self-Check, Ultraviolet Flame Detectors. Use R7847C1005 Amplifier.
- ⑩ Order remote reset module, part no. S7820A1007, Data ControlBus Module™ (part no. S7810A1009) or Keyboard Display Module (part no. S7800A1001).

TABLE 12—HONEYWELL CROSS-REFERENCE FOR FIREYE™ TFM2,3 AND UVM2,3,5

Device To Be Replaced	Replacement (1) (2) (3) (4) (6) (7) (8) (9) (11) (12)	7800 Replace- ment (1) (5) (6) (7) (8) (9) (11) (12)	Voltage (Vac)	Frequency (Hz)	Flame Detector Type	FFRT (Sec)	PFEF (Sec)	Prepurge Timing (Sec)	Comments
TFM-2A7	R7795B1009 (13)	RM7895A1014 (13)	120	50/60	Rectification	2-4	12	7	
	R7795F1000 (5) (13)	RM7895B1013 (5) (13)							
TFM-2A30	R7795B1009 (13)	RM7895A1014 (13)	120	50/60	Rectification	2-4	12	30	
	R7795F1000 (5) (13)	RM7895B1013 (5) (13)							
TFM-2A90	R7795B1009 (13)	RM7895A1014 (13)	120	50/60	Rectification	2-4	12	90	
	R7795F1000 (5) (13)	RM7895B1013 (5) (13)							
TFM3-7	R7795B1009 (13)	RM7895A1014 (13)	120	50/60	Rectification	2-4	12	7	Nonrecycle
TFM3-3H	R7795F1000 (5) (13)	RM7895B1013 (5) (13)							
TFM3-90	R7795B1009 (13)	RM7895A1014 (13)	120	50/60	Rectification	2-4	12	90	Nonrecycle
	R7795F1000 (5) (13)	RM7895B1013 (5) (13)							
TFM2	R7795B1009 (13)	RM7895A 1014 (13)	120	50/60	Rectification	2-4	4,10	(2)	
	R7795F1000 (5) (13)	RM7895B1013 (5) (13)							
TFM3X3H	R7795B1009 (13)	RM7895A1014 (13)	120	50/60	Rectification	2-4	4,10	(2)	Nonrecycle
	R7795F1000 (5) (13)	RM7895B1013 (5) (13)							
UVM-2A	R7795A1001 (13)	RM7895A1014 (13)	120	50/60	Ultraviolet	2-4	12	30	
	R7795E1002 (5) (13)	RM7895B1013 (5) (13)							
UVM-2A7	R7795A1001 (13)	RM7895A1014 (13)	120	50/60	Ultraviolet	2-4	12	7	
	R7795E1002 (5) (13)	RM7895B1013 (5) (13)							
UVM-2A30	R7795A1001 (13)	RM7895A1014 (13)	120	50/60	Ultraviolet	2-4	12	30	
	R7795E1002 (5) (13)	RM7895B1013 (5) (13)							
UVM-2A90	R7795A1001 (13)	RM7895A1014 (13)	120	50/60	Ultraviolet	2-4	12	90	
	R7795E1002 (5) (13)	RM7895B1013 (5) (13)							
UVM3-7	R7795A1001 (13)	RM7895A1014 (13)	120	50/60	Ultraviolet	2-4	12	7	Nonrecycle
	R7795E1002 (5) (13)	RM7895B1013 (5) (13)							
UVM3-90	R7795A1001 (13)	RM7895A1014 (13)	120	50/60	Ultraviolet	2-4	12	90	Nonrecycle
	R7795E1002 (5) (13)	RM7895B1013 (5) (13)							
UVM2	R7795A1001 (13)	RM7895A1014 (13)	120	50/60	Ultraviolet	2-4	4,10 (2)	(2)	
	R7795E1002 (5) (13)	RM7895B1013 (5) (13)							
UVM3+3H	R7795A1001 (13)	RM7895A1014 (13)	120	50/60	Ultraviolet	2-4	4,10 (2)	(2)	Nonrecycle
	R7795E1002 (5) (13)	RM7895B1013 (5) (13)							
UVM5	R7795C1007 (14)	RM7895C1012 (14)	120	50/60	Ultraviolet	2-4	4,10 (2)	(2)	Nonrecycle
	R7795G1008 (5) (14)	RM7895D1011 (5) (14)							

FOOTNOTES:

- ① The R7795 control is not a direct, plug-in replacement. See Modernization Wiring Information section for wiring diagrams.
- ② These Fireye™ devices use a plug-in "MT" timer card, which includes a 10 second trial for ignition timing and prepurge timing. MT710 provides a 7 second prepurge and a 10 second TFI. MT3010 provides a 30 second prepurge and a 10 second TFI, etc.
- ③ Use Q795A Subbase.
- ④ Use ST795A Plug-in Purge Timers.
- ⑤ Provides air-flow switch check (AFSC).

- ⑥ 4 or 10 second PFEP.
- ⑦ Use Q7800A (panel mount) or Q7800B (burner mount) Subbase.
- ⑧ Select proper flame signal amplifier.
- ⑨ Use ST7800A Plug-in Purge Timers.
- ⑩ 10 second MFEP.
- ⑪ Can be used with C7012E,F Dynamic Self-Check, Ultraviolet Flame Detectors. Use R7847C Amplifier.
- ⑫ 120 Vac, 60 Hz replacement is indicated. Identical model available with 120 Vac, 50 Hz.
- ⑬ Intermittent pilot.
- ⑭ Interrupted pilot.



PRINTED IN U.S.A.



Printed on recycled paper containing at least 10% post-consumer paper fibers.