

Two Way and Three Way Valve Bodies, Components, and Assemblies

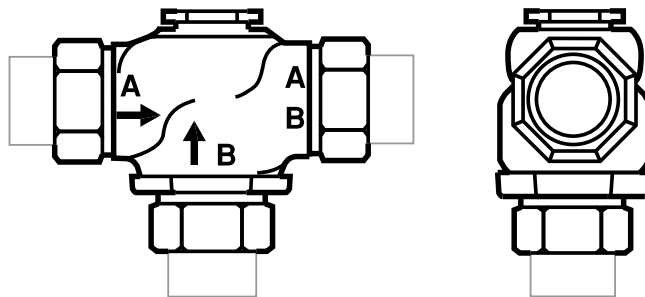
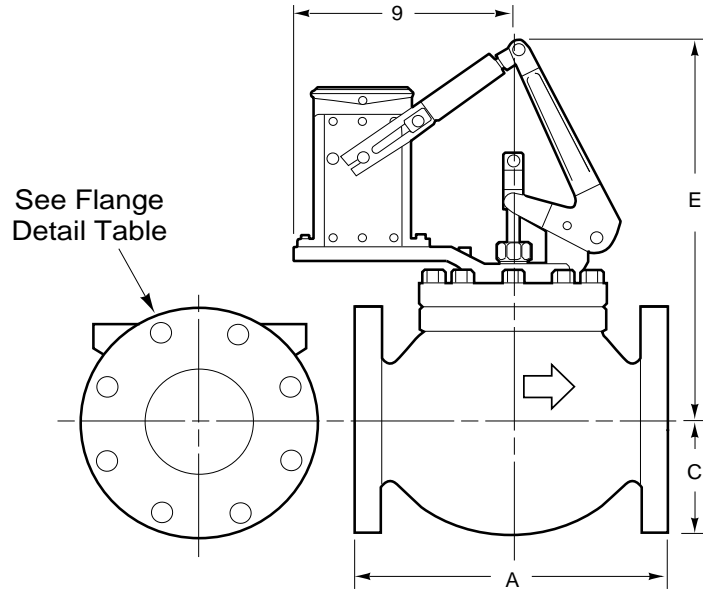

Barber-Colman Company
Industrial Instruments Division

Selection
Guide

Two Way
Valves

Three Way
Valves

General
Information

Linkages

ISO 9001

Commitment to Quality

International Standards

The International Standards Organization provides a series of international standards that are used to measure the Quality System of an organization and how it is managed. ISO 9001 is a specific standard that is applied to an organization that designs and manufactures products. The focus of this standard is how the Quality System assures the quality of the parts and services a company produces. ISO 9001 also looks at how a management system collects quality related data, and utilizes it to continually improve operations, reliability, productivity and other characteristics. Therefore, when an organization becomes certified under ISO 9001, it is the management system that has been certified.

Certification

On June 14, 1994, DNV (Det Norske Veritas Certification, Inc.) determined that the Quality System of the Industrial Instruments Division of Barber-Colman Company is certified to ISO 9001. This certification represents a standard of consistency and view of quality that is accepted worldwide. It allows a common point of reference in terminology and functional concepts that enhances our customer communications. When choosing among potential suppliers, customers can count on the characteristics of Barber-Colman as an ISO 9001 certified supplier.

Commitment

The Quality Manual and Procedures that form the basis of our Quality System originate from our stated quality policy: The Quality Objective of the Industrial Instruments Division of Barber-Colman Company is to provide quality products and services that meet or exceed customer requirements. To achieve our Quality Objective, the Industrial Instruments Division is committed to:

- Implementing and maintaining a continuous improvement process.
- Implementing and maintaining the Quality System described in the Quality Manual and the Procedure Manual.
- Ensuring the Quality Policy is communicated and understood at all levels of the organization.
- Providing adequate resources and assigning trained personnel for management, performance of work, verification activities and audits.

ISO 9001 Key Elements

- 1) Management responsibility to establish a quality representative and organization that provides feedback to management on quality issues.
- 2) Establish a documented quality system including a Quality Manual and Procedures.
- 3) Verify the needs and expectations of the customer.
- 4) Control and verify the design of new products to ensure specified requirements are met.
- 5) Control of all documents related to the control of quality.
- 6) Ensure that purchasing material and suppliers conform to specified requirements.
- 7) Identify and trace products through all stages of manufacturing.
- 8) Provide documented plans for control of all manufacturing processes.
- 9) Inspection and testing to verify requirements are met.
- 10) Equipment used for inspection, measurement and test is calibrated and maintained.
- 11) Inspection and test status of manufactured product is clearly identified.
- 12) Non-conforming product is prevented from unintended use.
- 13) Implementation of a system for corrective and preventive action.
- 14) Handling, storage, packaging and delivery procedures that prevent damage.
- 15) Establish and retain records that support the Quality System.
- 16) Verification of Quality System compliance through internal quality audits.
- 17) Identification and documentation of employee qualification, education and training needs.
- 18) Establish and utilize statistical techniques for process monitoring.

Table of Contents

Two-Way Valve Selection	6
Three-Way Valve Selection	8
Union End, Flared; Hydraulic	9
Screwed, Union Sweat; Hydraulic	12
Screwed, Union Sweat; Electric	15
High Temp; Electric	22
Mixing, Sequencing; Flared	25
Mixing, Diverting; Hydraulic	28
Mixing, Diverting; Electric	31
Static Pressure Versus Temperature Ratings	42
Flow Curves and Rangeability	43
Guidelines	44
Valve Sizing Information for Water	46
Valve Sizing Information for Steam	49
Valve/Actuator Wiring Diagrams	52
Valve Body Cross Reference	59
Valve Linkage Selection Guide	60
Valve Linkages	66

Selection Guide

How to Use this Guide

This guide will direct you to

- part numbers of valve assemblies for specific types of applications
- part numbers of components of those assemblies – valve body, actuator, linkage.

The model numbering scheme on the next page explains how the part number is composed.

To find the part number of the assembly or component you need:

- 1) Refer to the table on page 6 or 7 for two way valves, and page 8 for three way valves.
- 2) Find the appropriate application parameters in the first row of the table.
- 3) Select the desired valve body type that is designed for that application.
- 4) To determine the actuator and linkage part numbers, follow the column down to the lower table.
- 5) Find the appropriate actuator input signal in the left column of the lower table.
- 6) Go to the first page number indicated to begin the assembly selection procedure. There you will find the following tables:

Table 1. Valve body specifications

Table 2. Valve actuator specifications

Table 3. Factory assemblies (two way) or dimensions (three way)

Table 4. Dimensions (two way) or flow patterns (three way)

Table 5. Restrictions

Selection Guide

Model: 0 0 - 0 - - -

Field No. 1 2 3 4 5 6 7 8 9 10 11 12 13 14 15

Fields 1, 2. RESERVED

Fields 3, 4. STYLE

- VA - Two position (SPST)
- VB - Valve body only
- VC - Two position (SPDT)
- VF - Floating SPDT
- VP - Multiple Electric/Electronic Input
- VS - Hydraulic type

Field 5. RESERVED

Fields 6 through 8. BODY

Two Way

- 222 - Globe, steel, s.s. trim
- 721 - Stem up open, brass trim with disc
- 921 - Stem up open, brass trim with disc
- 722 - Stem up closed, brass trim with disc
- 922 - Stem up closed, brass trim with disc
- 725 - Stem up open, s.s. trim with disc
- 726 - Stem up closed, s.s. trim with disc
- 727 - Stem up open, s.s. trim
- 728 - Stem up closed, s.s. trim

Three Way

- 731 - Mixing
- 931 - Mixing
- 732 - Diverting
- 733 - Sequencing

Field 9. END FITTING

- 1 - Union
- 2 - Flared
- 3 - Screwed or flanged
- 4 - Union Sweat

Fields 10, 11 & 12. ACTUATOR

- 000 - None – valve body only
- XXX - Appropriate actuator from selection table

Field 13. PATTERN

- 1 - Straightway, high temperature water
- 2 - Globe, flanged, high pressure steam
- 3 - Angle
- 4 - Straightway
- 5 - Globe, flanged

Fields 14, 15. VALVE SIZE PORT CODE

Size codes 1 through 16 for 1/2" to 6" valve size.

Two-Way

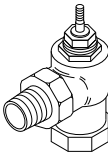
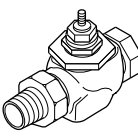
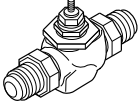
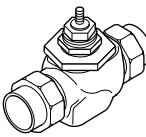
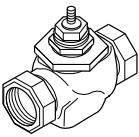
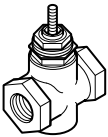
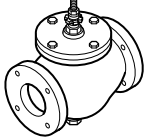
Valve Application	Chilled or Hot Water 281°F Maximum; 35 psig Maximum Steam						
Valve Body Type	Union, Angle	Union, Straightway	Flared	Union, Sweat	Screwed	Screwed	Flanged
							
Stem Up Open	VB-7211-0-3-P	VB-7211-0-4-P	VB-7212-0-4-P	VB-7214-0-4-P	VB-7213-0-4-P	VB-9213-0-4-P	VB-9213-0-5-P
Stem Up Closed	Not Available	VB-7221-0-4-P ^a	VB-7222-0-4-P ^a	VB-7224-0-4-P ^a	VB-7223-0-4-P ^a	VB-9223-0-4-P ^a	VB-9223-0-5-P ^a
Static Pressure Rating	250 psig	250 psig	250 psig	250 psig	250 psig	250 psig	125 psig
Sizes Available	1/2 to 1-1/4 in.	1/2 to 1-1/4 in.	5/8 in. O.D., SAE 45°	1/2 to 2 in.	1/2 to 2 in.	2-1/2 & 3 in.	2-1/2 to 6 in.
Range of Cv's Available	0.4 to 20	0.4 to 20	0.4 to 4.4	0.4 to 40	0.4 to 40	65 & 85	56 to 350
Flow Type	Equal %	Equal %	Equal %	Equal %	Equal %	Equal %	Equal %

ELECTRIC/ ELECTONIC ACTUATORS

Input Signals	Pages						
Two-Position (SPST) (Spring Return)	to 11	8 to 11	8 to 11	12 to 14	12 to 14	12 to 14	to 21
Two-Position (SPDT Snap Acting) (Non-Spring Return)					to 21	to 21	to 21
Voltage Input 2 to 15 Vdc	to 11	to 11	to 11	12 to 14	12 to 14	12 to 14	12 to 14
Current Input 4 to 20 mA etc.					12 to 21	12 to 21	12 to 21
Floating Control, SPDT or Two SPST, Direct Digital Control					to 21	to 21	to 21

^a Not applicable with gear train actuators. Use stem up open valve body with N.C. actuator.

1. Select the vertical column that has a valve body series that meets your requirements.
2. Select the row with correct input signal.
3. The intersection cell shows the pages for complete selection and ordering information.

Two-Way

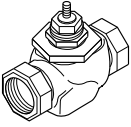
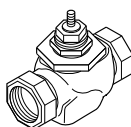
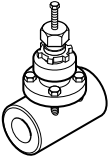
Valve Application	Hot Water 300°F Max.; 100 psig Max. Steam	Hot Water 366°F Max.; 150 psig Max. Steam	High Temp. Water High Pressure Steam
Valve Body Type	Screwed	Screwed	1/2 to 1-1/2 in. Screwed 1 in., 1-1/2 in. Flanged
			
Stem Up Open	VB-7253-0-4-P	VB-7273-0-4-P	VB-222-0-1-P VB-222-0-2-P
Stem Up Closed	VB-7263-0-4-P ^a	VB-7283-0-4-P ^a	Not Available
Static Pressure Rating	250 psig	250 psig	600 psig G.S. 300 psig G.F.
Sizes Available	1/2 to 2 in.	1/2 to 2 in.	1/2 to 1-1/2 in.
Range of Cv's Available	0.4 to 40	0.4 to 40	0.95 to 35.8
Flow Type	Throttling	Throttling	Equal %

ELECTRIC/ELECTRONIC ACTUATORS



Input Signals	Pages		
Two-Position (SPST) (Spring Return)	12 to 14	12 to 14	to 24
Two-Position (SPDT Snap Acting) (Non-Spring Return)	to 21	to 21	22 to 24
Voltage Input 2 to 15 Vdc	12 to 14	12 to 14	22 to 24
Slidewire	14 to 21	14 to 21	22 to 24
Current Input 4 to 20 mA etc.			
Floating Control, SPDT or Two SPST, Direct Digital Control			

^a Not applicable with gear train actuators. Use stem up open valve body with N.C. actuator.

HOW TO USE TABLE:

1. Select the vertical column that has a valve body series that meets your requirements.
2. Select the row with the correct input signal.
3. The intersection cell shows the pages with complete selection and ordering information.

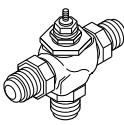
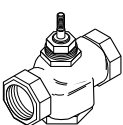
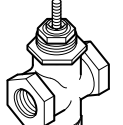
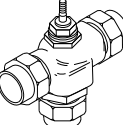
Three-Way

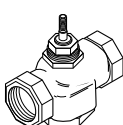
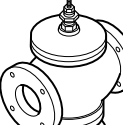
Valve Application	Chilled or Hot Water 281°F Maximum				Chilled or Hot Water 300°F Maximum	Chilled or Hot Water 281°F Maximum	Chilled or Hot Water 300°F Maximum
	Flared	Screwed	Screwed	Union Sweat	Flanged	Screwed	Flanged
							
	VB-7312-0-4-P	VB-7313-0-4-P	VB-9313-0-4-P	VB-7314-0-4-P	VB-9313-0-5-P	VB-7323-0-4-P	VB-9323-0-5-P
Static Pressure Rating	250 psig	250 psig	250 psig	250 psig	125 psig	250 psig	125 psig
Sizes Available	5/8 in. O.D., SAE 45°	1/2 to 2 in.	2-1/2 & 3 in.	1/2 to 2 in.	2-1/2 to 6 in.	1/2 to 2 in.	2-1/2 to 6 in.
Range of Cv's Available	2 to 4.4	2 to 50	67 to 91	2 to 50	74 to 390	6 to 42	75 to 275
Flow Type	Mixing	Mixing	Mixing	Mixing	Mixing	Diverting	Diverting

ELECTRIC/ ELECTRONIC ACTUATOR

Input Signals	Pages						
Two-Position (SPST) (Spring Return)	25 to 27	28 to 40	28 to 40	28 to 40	31 to 40	28 to 40	31 to 40
Two-Position (SPDT Snap Acting) (Non-Spring Return)		31 to 40	31 to 40	31 to 40	31 to 40	31 to 40	31 to 40
Voltage Input 2 to 15 Vdc	25 to 27	28 to 40	28 to 40	28 to 40	28 to 40	28 to 40	28 to 40
Slidewire							
Current Input 4 to 20 mA etc.		31 to 40	31 to 40	31 to 40	31 to 40	31 to 40	31 to 40
Floating Control, SPDT or Two SPST, Direct Digital Control							

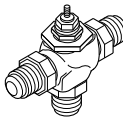
Valve Application	Chilled or Hot Water 281°F Maximum
Valve Body Type	Flared
	
	VB-7332-0-4-P
Static Pressure Rating	250 psig
Sizes Available	5/8 in. O.D., SAE 45°
Range of Cv's Available	1.3 to 4.4
Flow Type	Sequencing

ELECTRIC/ ELECTRONIC ACTUATORS

Input Signals	Pages
Voltage Input 2 to 15 Vdc	25 to 27

HOW TO USE TABLE:

1. Select the vertical column that has a valve body series that meets your requirements.
2. Select the row with the correct input signal for the actuator.
3. The intersection of the two columns shows the pages for complete selection and ordering information.

Union End, Flared; Hydraulic

TABLE 1. Select Valve Body including P Code (Valve Size, Cv Rating, Port Code) or select Valve Assembly with correct Input Signal (refer to Table 3 also) less Actuator Code (XXX) including the P Code (Size, Cv Rating, Port Code). (Refer to Pages 46 to 51 for Valve Sizing.)

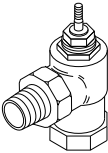
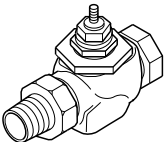
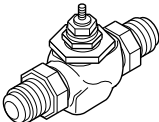
		Application		
		Chilled or Hot Water 281°F Max; 35 psig Steam		
		Union, Angle	Union, Straightway	Flared
				
Size		1/2 to 1-1/4 in.	1/2 to 1-1/4 in.	5/8 in. O.D., SAE 45°
Normally Open Valves	Valve Body	VB-7211-0-3-P	VB-7211-0-4-P	VB-7212-0-4-P
	Valve Assembly, 4 to 20 mA, 135Ω	VS-7211-XXX-3-P	VS-7211-XXX-4-P	VS-7212-XXX-4-P
Normally Closed Valves	Valve Body	—	VB-7221-0-4-P	VB-7222-0-4-P
	Valve Assembly, 4 to 20 mA, 135 Ω	—	VS-7221-XXX-4-P	VS-7222-XXX-4-P
		Flow Type Equal % (Refer to page 43)		
Material	Body	Bronze	Bronze	Bronze
	Seat	Stainless Steel	Stainless Steel	Stainless Steel
	Stem	Brass	Brass	Brass
	Plug	Spring Loaded TFE	Spring Loaded TFE	Spring Loaded TFE
	Packing	Composition	Composition	Composition
	Disc	250 (up to 400 psig below 150°F)		250
ANSI Pressure Class ^a (psig) Refer to page 42				
Maximum Inlet Pressure Steam psig (kPa)		35 (241)		
Allowable Control Media Temp ^b		20 to 281°F (-7 to 138°C)		
Allowable Differential Pressure for Water psig (kPa)		35 psi (241) Max. for normal life (Refer to page 46 for cavitation limits)		
Allowable Differential Pressure for Steam		20 psi (138 kPa)		

NOTE: It is possible to select either a valve assembly or component parts (actuator, valve linkage, valve body).

ORDERING EXAMPLES:

1. Valve Assembly . . VA-7221-268-4-8
 2. Valve Body VB-7221-0-4-8
- Actuator EA81
Linkage AV-600

- Valve Body Data less P Code (Size, Cv Rating, Port Code) or Valve Assembly less Actuator Code (XXX) and less P Code (Size, Cv Rating, Port Code)
- P Code (Size, Cv Rating, Port Code)
- Actuator or Actuator Code (XXX) for Valve Assemblies
- Valve Linkage

TO SELECT A PORT CODE (P).

P Code	Valve Size ^a in.	Cv		
-1 ^c	1/2 or 5/8	0.4	0.4	0.4
-2 ^c		1.3	1.3	1.3
-3 ^c		2.2	2.2	2.2
-4		4.4	4.4	4.4
-5 ^c	3/4	5.5	5.5	—
-6		7.5	7.5	
-7 ^c	1	10	10	
-8 ^c		14	14	
-9		20	20	

^a CAUTION: Fittings and/or piping schedules must meet or exceed working static pressure requirements.

^b CAUTION: Freeze protection required for fluid temperatures below 32°F (0°C). Do not use Hydraulic Actuators with fluid temperatures below 40°F (4°C).

^c Factory assemblies are not available for two-position applications using reduced port valve bodies.

Two Way Valves

Union End, Flared; Hydraulic

TABLE 2. Select Actuator Type with correct input signal having sufficient close-off for the application. If selecting component parts, select valve linkage.

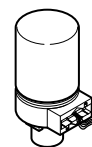

			Input Signal		Electronic Vdc 4 to 20 mA
			Valve Linkage		AV-7600
			Actuator Type		EA81
N.P.	Factory Available Valve Assemblies	Valve Body	P Code	Size in.	Close off Pressure
	VS-7211-XXX-3-P	VB-7211-0-3-P	-1-2-3-4	1/2	100
			-5-6	3/4	80
			-7-8	1	45
			-9	1-1/4	25
N.O.	VS-7211-XXX-4-P VS-7212-XXX-4-P	VB-7211-0-4-P VB-7212-0-4-P	-1-2-3-4	1/2 [5/8] ^a	190
			-5-6	3/4	85
			-7-8	1	45
			-9	1-1/4	30
N.C.	VS-7221-XXX-4-P VS-7222-XXX-4-P	VB-7221-0-4-P VB-7222-0-4-P	-1-2-3-4	1/2 [5/8] ^a	220
			-5-6	3/4	90
			-7-8	1	50
			-9	1-1/4	30

^a 5/8 O.D. SAE 45° fittings on VB-7212 and VB-7222 valves.

Union End, Flared; Hydraulic

TABLE 3. Factory Assemblies, select exact Actuator Code (XXX) (135Ω, or 4 to 20 mAdc). Any EA81 can be assembled to 1/2 to 1-1/4 in. valve bodies with the close-off pressure ratings listed in Table 2. Select below listed Hydraulic Actuators or Actuator Codes (XXX) for factory available assemblies. For applications that factory assemblies are not available, select actuator, linkage, body and field assemble.

Input Signal	Wiring Figure No. ^a	Voltage Vac 50/60 Hz	VA	Actuator Part No.	Actuator Code (XXX) for Factory Available Assembly
VS-72XX					
4 to 20 mA	Figure 10 on page 57	120	18	EA81-11006	268
135 Ω				EA81-17006	278

^a Refer to the Valve/Actuator Wiring Diagrams in this section.

TABLE 4. Dimensions in Inches (Millimeters). Refer to page 11 for illustrations.

Part Number Series	Size in.	Valve Body			Actuator Series
		A	B	C	EA81
VB-7211 (Angle)	1/2	3-1/2 (89)	2-5/8 (67)	1-5/8 (41)	8-1/8 (206)
	3/4	3-13/16 (97)	2-3/4 (70)	1-3/4 (44)	8-3/16 (207)
	1	4-1/4 (107)	3-1/8 (79)	2 (51)	8-7/16 (214)
VB-7211 (Straight)	1-1/4	4-3/8 (117)	3-3/8 (86)	2-1/8 (54)	8-1/2 (216)
	1/2	4-1/4 (108)	2-3/4 (70)	1-7/16 (36)	8-1/16 (204)
	3/4	4-3/4 (121)	2-15/16 (75)	1-7/16 (36)	8-1/2 (215)
VB-7212	1	6-1/8 (156)	3-13/16 (97)	2-1/8 (53)	9 (228)
	1-1/4	6-3/8 (162)	4-1/16 (103)	1-7/16 (37)	8-5/8 (219)
	5/8	4 (102)	—	1-7/16 (36)	8-1/16 (204)
VB-7221	1/2	4-1/4 (108)	2-3/4 (70)	1-7/16 (36)	8 (203)
	3/4	4-3/4 (121)	2-15/16 (75)	1-7/16 (36)	8-5/16 (211)
	1	6-1/8 (156)	3-13/16 (97)	2-1/8 (53)	8-7/16 (214)
VB-7222	1-1/4	6-3/8 (162)	4-1/16 (103)	1-3/4 (45)	8-5/16 (210)
	5/8	4 (102)	—	—	8 (203)

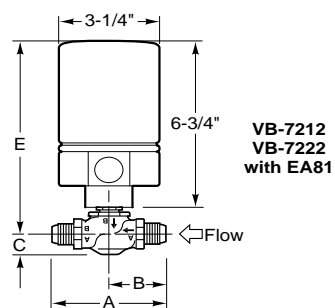
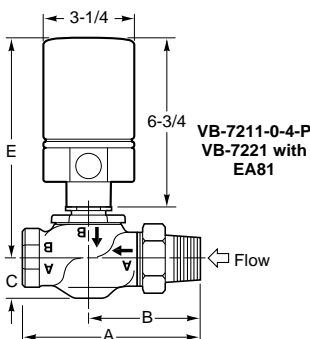
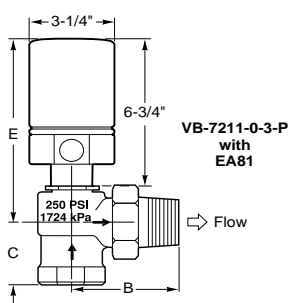

^a AV-601 linkage extension (not shown) required for hot water applications. Refer to Table 4.

TABLE 5. Restrictions on Maximum Ambient Temperature for Valve Actuators.

Temperatures °F (°C) EA81			
Linkage Extension		None	AV-601
Maximum Ambient		140 (60)	140 (60)
Max. Allowable Fluid		181 (83)	281 (138)
VB-7211	Maximum Fluid	281 (138)	
VB-7212			
VB-7221	Max. Allowable Ambient	115 (46)	140 (46)
VB-7222			

CAUTION: Avoid condensation which can facilitate corrosion. With 40°F (4°C) water, the maximum allowable ambient dew point temperature is 68°F (20°C). Piping insulation must not stop drainage at actuator mounting nut. Do not use Hydraulic Actuators with fluid temperatures below 40°F (4°C).

Screwed, Union Sweat; Hydraulic

TABLE 1. Select Valve Body including P Code (Valve Size, Cv Rating, Port Code) or select Valve Assembly with correct Input Signal (refer to Table 3 also) less Actuator Code (XXX) including the P Code (Size, Cv Rating, Port Code). (Refer to Pages 44 to 49 for Valve Sizing.)

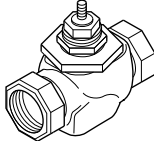
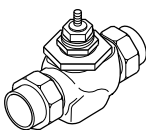
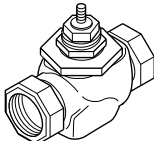
		Application			
		Chilled or Hot Water 281°F Max. 35 psig Steam		Hot Water 300°F Max. 100 psig Steam	Hot Water 366°F Max. 150 psig Steam
		Screwed NPT	Union Sweat	Screwed NPT	
					
Size		1/2 to 1-1/4 in.	1/2 to 1-1/4 in. I.D.	1/2 to 1-1/4 in.	1/2 to 1-1/4 in.
Normally Open	Valve Body	VB-7213-0-4-P	VB-7214-0-4-P	VB-7253-0-4-P	VB-7273-0-4-P
	Valve Assembly, 4 to 20 mA, 135Ω	VS-7213-XXX-4-P	—	—	—
Normally Closed	Valve Body	VB-7223-0-4-P	VB-7224-0-4-P	VB-7263-0-4-P	VB-7283-0-4-P
	Valve Assembly, 4 to 20 mA, 135Ω	VS-7223-XXX-4-P	—	—	—
		Flow Type	Equal % (Refer to 43)		Throttling (Refer to 43)
Material	Body	Bronze	Bronze	Bronze	Bronze
	Seat	Bronze	Bronze	Stainless Steel	Stainless Steel
	Stem	Stainless Steel	Stainless Steel	Stainless Steel	Stainless Steel
	Plug	Brass	Brass	Stainless Steel	Stainless Steel
	Packing	Spring loaded TFE	Spring loaded TFE	Spring loaded TFE	Spring loaded TFE
		Disc	Composition	Composition	Teflon
		ANSI Pressure Class (psig)	250 (up to 400 psig below 150°F, see 42)		
		Maximum Inlet Pressure Steam psig (kPa)	35 (241)		100 (690)
		Allowable Control Media Temp ^a	20 to 281°F (-7 to 138°C)	20 to 281°F (-7 to 138°C)	20 to 300°F (-7 to 149°C)
		Allowable Differential Pressure for Water psig (kPa)	35 psi (241) Max. for normal life (Refer to 46 for cavitation limits)		35 (241)
		Allowable Differential Pressure for Steam	20 psi (138 kPa)	20 psi (138 kPa)	35 psi (241 kPa)
					50 (345)
					50 psi (345 kPa)

NOTE: It is possible to select either a valve assembly or component parts (actuator, valve linkage, valve body).

1. **Valve Assembly:**
VS-7223-268-4-8

2. **Valve Body:**
VB-7223-0-4-8
Actuator: EA81

Linkage: AV-600

- Valve Body Data less P Code (Size, Cv Rating, Port Code) or Valve Assembly less Actuator Code (XXX) and less P Code (Size, Cv Rating, Port Code)
- P Code (Size, Cv Rating, Port Code)
- Actuator or Actuator Code (XXX) for Valve Assemblies
- Valve Linkage

TO SELECT A PORT CODE (P).

P Code	Valve Size in.	Cv			
-1 ^b	1/2	0.4	0.4	0.4	0.4
-2 ^b		1.3	1.3	1.3	1.3
-3 ^b		2.2	2.2	2.2	2.2
-4		4.4	4.4	4.4	4.4
-5 ^b	3/4	5.5	5.5	5.5	5.5
-6		7.5	7.5	7.5	7.5
-7 ^b	1	10	10	10	10
-8		14	14	14	14
-9	1-1/4	20	20	20	20

^a CAUTION: Freeze protection required for fluid temperatures below 32°F (0°C). Do not use Hydraulic Actuators with fluid temperatures below 40°F (4°C).

^b Factory assemblies are not available for two-position applications using reduced port valve bodies.

Screwed, Union Sweat; Hydraulic

TABLE 2. Select Actuator Type or Actuator Code (XXX) series with correct Input Signal having sufficient close-off for the application. If selecting Component Parts, select Valve Linkage.

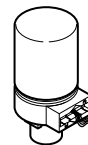

Input Signal					Electronic Vdc 4 to 20 mA Floating SPDT 135 Ohm Slidewire
Valve Linkage		1/2 to 1-1/4 in. Valve			AV-7600^a/AV7601
Actuator Code (XXX)					268, 278
Actuator					EA81
N.P.	Factory Available Valve Assembly	Valve Body	P Code	Size in.	
N.O.	VS-7213-XXX-4-P	VB-7213-0-4-P	-1-2-3-4	1/2	190
			-5-6	3/4	85
			-7-8	1	45
			-9	1-1/4	30
N.C.	VS-7223-XXX-4-P	VB-7223-0-4-P	-1-2-3-4	1/2	220
			-5-6	3/4	90
			-7-8	1	50
			-9	1-1/4	30

^a use AV-600 and AV-601.

TABLE 3. Factory Assemblies, select exact Actuator Code (XXX). Any EA81 can be assembled to 1/2 to 1-1/4 in. valve bodies with the close-off pressure ratings listed in Table 2. Select below listed Hydraulic Actuators or Actuator linkage Codes (XXX) for factory available assemblies. For applications that factory assemblies are not available, select actuator, linkage, valve body and field assemble.

Input Signal	Wiring Figure No. ^a	Voltage Vac 50/60 Hz	VA	Actuator Part No.	Actuator Code (XXX) for Factory Available Assembly
					VS-72X3
4 to 20 mA	Figure 10 on 57	120	18	EA81-11006	268
135Ω		120		EA81-17006	278

^a Refer to the Valve/Actuator Wiring Diagrams in the General Information section.

Two Way Valves

Screwed, Union Sweat; Hydraulic

TABLE 4. Dimensions in Inches (Millimeters).

Valve Body					Actuator Series EA81
Part Number	Size In.	A	B ^a	C	E
VB-7213-0-4-P	1/2	3 (76)	4-1/4 (108)	1-7/16 (36)	7-3/4 (197)
VB-7214-0-4-P	3/4	3-5/8 (92)	5-1/2 (140)	1-7/16 (36)	8-13/16 (223)
VB-7253-0-4-P	1	4-5/8 (117)	6-3/4 (171)	2-1/8 (53)	9-1/16 (230)
VB-7273-0-4-P	1-1/4		6-7/8 (175)	1-13/16 (46)	8-5/8 (219)
VB-7223-0-4-P	1/2	3 (76)	4-1/4 (108)	1-7/16 (36)	7-3/4 (197)
VB-7224-0-4-P	3/4	3-5/8 (92)	5-1/2 (140)	1-7/16 (36)	8-13/16 (223)
VB-7263-0-4-P	1	4-5/8 (117)	6-3/4 (171)	2-1/8 (53)	9-1/16 (230)
VB-7283-0-4-P	1-1/4		6-7/8 (175)	1-12/16 (45)	8-5/16 (210)

^a Use B dimension for VB-7214 and VB-7224 valve bodies.

NOTE: Allow 3 inches clearance above actuator for removal. Mount EA81 actuators above the valve body at 45° from vertical on steam applications.

Two Way Valves

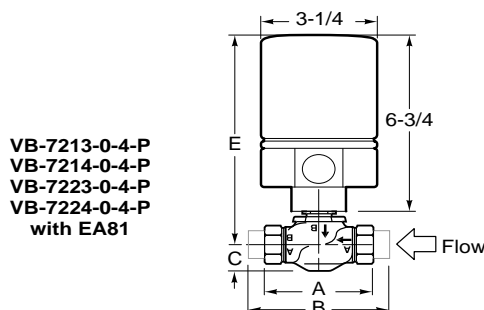

TABLE 5. Restrictions on Maximum Ambient Temperature for Valve Actuators.

Temperatures °F (°C)		
Actuator Code (XXX)		268, 278
Actuator Series		EA81
Maximum Ambient		140 (60)
Max. Allowable Fluid		140 (60)
VB-7213-0-4-P VB-7214-0-4-P VB-7223-0-4-P VB-7224-0-4-P	Maximum Fluid	281 (138)
	Max. Allow. Ambient	103 (39)
VB-7523-0-4-P VB-7263-0-4-P	Maximum Fluid	340 (171)
	Max. Allow. Ambient	93 (34)
VB-7273-0-4-P VB-7283-0-4-P	Maximum Fluid	366 (186)
	Max. Allow. Ambient	88 (31)

CAUTION: Avoid condensation which can facilitate corrosion. With 40°F (4°C) water, the maximum allowable ambient dew point temperature is 68°F (20°C). Piping insulation must not stop drainage at actuator mounting nut. Do not use Hydraulic Actuators with fluid temperatures below 40°F (4°C).

Screwed, Union Sweat; Electric

TABLE 1. Select Valve Body including P Code (Valve Size, Cv Rating, Port Code) or select Valve Assembly with correct Input Signal (refer to Table 3 also) less Actuator Code (XXX) including the P Code (Size, Cv Rating, Port Code). (Refer to Pages 44 to 49 for Valve Sizing.)

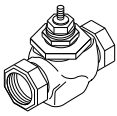
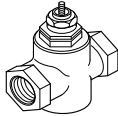
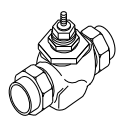
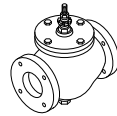
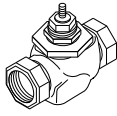
	Application					
	Chilled or Hot Water 281°F Max. 35 psig Steam				Hot Water 300°F Max. 100 psig Steam	Hot Water 366°F Max. 150 psig Steam
	Screwed NPT	Screwed NPT	Union Sweat	Flanged	Screwed NPT	
						
Size	1/2 to 2 in.	2-1/2 & 3 in.	1/2 to 2 in. I.D.	2-1/2 to 6 in.	1/2 to 2 in.	1/2 to 2 in.
Valve Body (stem down to close) Actuator Provides Normal Position	VB-7213-0-4-P	VB-9213-0-4-P	VB-7214-0-4-P	VB-9213-0-5-P	VB-7253-0-4-P	VB-7273-0-4-P

Normal Position	Actuator Series	Input Signal	Factory Available Assemblies				
			VA-7213-3XX-4-P	VA-9213-3XX-4-P	VA-7214-3XX-4-P	VP-9213-3XX-5-P	VF-9213-30X-5-P
N.O. or N.C. (Refer to Table 3)	EA12	SPST (Refer to Table 3)	VA-7213-3XX-4-P	VA-9213-3XX-4-P	VA-7214-3XX-4-P	—	—
	EA4X	(Refer to Table 3B)	VP-7213-3XX-4-P	VP-9213-3XX-4-P	VA-7214-3XX-4-P	VP-9213-3XX-5-P	—
	MF-221X3 ^a	Floating SPDT	VF-7213-25X-4-P	—	—	—	—
None (Non-Spring Return. Refer to Table 3)	MF-631X3	Floating SPDT and Multiple Input (Refer to Table 3D)	VF-7213-30X-4-P	VF-9213-30X-4-P	—	VF-9213-30X-5-P	—
	EA31	SPDT, Snap Acting (Refer to Table 3A)	VC-7213-4XX-4-P	VC-9213-4XX-4-P	VA-7214-4XX-4-P	VC-9213-4XX-5-P	—
	EA58	(Refer to Table 3B)	VP-7213-4XX-4-P	VP-9213-4XX-4-P	VA-7214-4XX-4-P	VP-9213-4XX-5-P	—
	EA76	(Refer to Table 3B)	—	—	—	VP-9213-9XX-5-P	—

NOTE: It is possible to select either a valve assembly or component parts (actuator, valve linkage, valve body).

- Valve Assembly: VS-9213-466-5-14**
- Valve Body: VB-9213-0-5-14**
Actuator: EA58
Linkage: AV-352

- Valve Body Data less P Code (Size, Cv Rating, Port Code) or Valve Assembly less Actuator Code (XXX) and less P Code (Size, Cv Rating, Port Code)

- P Code (Size, Cv Rating, Port Code)
- Actuator or Actuator Code (XXX) for Valve Assemblies
- Valve Linkage

Material	Flow Type	Equal % (Refer to page 42)				Throttling (Refer to page 42)	
	Body	Bronze	Bronze	Bronze	Cast Iron	Bronze	Bronze
	Seat	Bronze	Bronze	Bronze	Bronze	Stainless Steel	Stainless Steel
	Stem	Stainless Steel	Stainless Steel	Stainless Steel	Stainless Steel	Stainless Steel	Stainless Steel
	Plug	Brass	Brass	Brass	Brass	Stainless Steel	Stainless Steel
	Packing	Spring Loaded TFE	Spring Loaded TFE	Spring Loaded TFE	Spring Loaded TFE	Spring Loaded TFE	Spring Loaded TFE
	Disc	Composition	Composition	Composition	Composition	Teflon	None
	ANSI Pressure Class (psig) Refer to page 41	250 (up to 400 psig below 150°F)				125 (200 psig below 150°F)	250 (up to 400 psig below 150°F)
Maximum Inlet Pressure Steam (psig) (kPa)	35 (241)				35 (241)	100 (690)	150 (1034)
Allowable Control Media Temp ^b	20 to 281°F (-7 to 138°C)	40 to 281°F (4 to 138°C)	20 to 281°F (-7 to 138°C)	40 to 281°F (4 to 138°C)	20 to 281°F (-7 to 138°C)	20 to 281°F (-7 to 138°C)	20 to 281°F (-7 to 138°C)
Allowable Differential Pressure for Water (psig) (kPa)	35 psi (241) Max. for normal life (Refer to page 44 for cavitation limits)				35 (241)		
Allowable Differential Pressure for Steam	20 psi (138 kPa)	20 psi (138 kPa)	20 psi (138 kPa)	20 psi (138 kPa)	20 psi (138 kPa)	35 psi (241 kPa)	50 psi (345 kPa)

TO SELECT A PORT CODE (P).

P Code	Valve Size in.	Cv						
-1 ^c	1/2	0.4	—	0.4	—	0.4	0.4	
-2 ^c		1.3		1.3		1.3	1.3	
-3 ^c		2.2		2.2		2.2	2.2	
-4		4.4		4.4		4.4	4.4	
-5 ^c	3/4	5.5	—	5.5	—	5.5	5.5	
-6		7.5		7.5		7.5	7.5	
-7 ^c	1	10	—	10	—	10	10	
-8		14		14		14	14	
-9		20		20		20	20	
-10	1-1/4	30	—	30	—	30	30	
-11	1-1/2	40		40		40	40	
-12	2-1/2	65		65		65	65	
-13	3	85		85		85	85	
-14	4	—	—	145	—	—	—	
-15	5			235				235
-16	6			350				350

^a MF-221X3 for hot water and steam applications only.

^b CAUTION: Freeze protection required for fluid temperatures below 32°F (0°C).

^c Factory assemblies are not available for two-position applications using reduced port valve bodies.

Two Way Valves

Screwed, Union Sweat; Electric

TABLE 2. Select Actuator Type or Actuator Code (XXX) series with correct Input Signal having sufficient close-off for the application. If selecting Component Parts, select Valve Linkage.

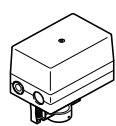
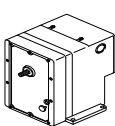
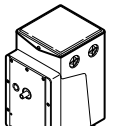
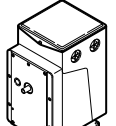
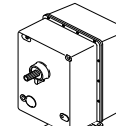
										
Input Signal		Floating SPDT		Floating SPDT and Multiple Input	Two-Position SPST	Refer to Table 3B	Refer to Table 3A, and Table 3B	Refer to Table 3B		
Valve Linkage	1/2 to 1-1/4 in.	AV-640 (Included)		AV-671 (Included)	AV-391	AV-391	AV-393	-		
	1-1/2 to 2 in.	—		AV-671 (Included)	AV-391	AV-391	AV-393			
	2-1/2 to 4 in.	—		AV-672 (order separately)	AV-395	AV-395	AV-396		AV-352	
	5 to 6 in.	—		—	—	—	—		AV-352	AV-358
Normal Position		None		None	N.O. or N.C.	N.O. or N.C.	None	None	None	
Valve Assembly Type		VF		VF	VA	VP or VS	VC, VP, VS	—		
Actuator Code (XXX)		251	253	301	303	301 311 321 322	317 318	417 423	465 466	952
Actuator Types		^a MF-22103	^a MF-22123	MF-63103	MF-63123	EA12	EA4X	EA31 EA58	EA76	

Factory Available Valve Assemblies	Valve Body	P Code	Size in.	CLOSE-OFF PRESSURE RATING (psi)													
				170	250	250	250	250	200	140							
VA-7213-3XX-4-P VC-7213-4XX-4-P VF-7213-2XX-4-P VP-7213-XXX-4-P VS-7213-XXX-4-P VF-7213-3XX-4-P	VB-7213-0-4-P VB-7214-0-4-P VB-7253-0-4-P VB-7273-0-4-P	-1-2-3-4	1/2	170	—	—	—	—	—	—							
		-5-6	3/4	76													
		-7-8	1	41							241	150	150	—			
		-9	1-1/4	26							156	90	90	200			
		-10	1-1/2	—							105	65	65	140			
		-11	2								59	35	35	80			
VA-9213-3XX-4-P VC-9213-4XX-4-P VF-9213-3XX-4-P VP-9213-XXX-4-P VS-9213-XXX-4-P	VB-9213-0-4-P	-12	2-1/2	—	—	—	—	—	—	—							
		-13	3								25	12	12	34	77		
		-12	2-1/2								37	20	20	50	112		
VA-9213-3XX-5-P VC-9213-4XX-5-P VF-9213-3XX-5-P VP-9213-5XX-5-P VS-9213-XXX-5-P	VB-9213-0-5-P	-13	3	—	—	—	—	—	—	—							
		-14	4								25	12	12	34	77		
		-15	5								14	6	6	17	42		
		-16	6								—	—	—	—	—	20	67
													—	—	—	—	14

^a MF-221X3 for hot water and steam applications only.

Two Way Valves

Screwed, Union Sweat; Electric

TABLE 3. Factory Assemblies (VA-92XX), Two-Position SPST Input, select exact Actuator Code (XXX). Any EA12 electric gear train actuator can be assembled to valve bodies with the close-off pressure ratings listed in Table 2. Select Actuator Type having sufficient close-off for the application. Select actuator, linkage, valve body and field assemble.

Input Signal	Normal Position	Wiring Figure No. ^a	Voltage	Hz	VA	Aux. Switch	Actuator	Actuator Code (XXX) for Factory Available Assembly
Two-Position SPST	Normally Open	Figure No. 1 on page 54	120	60	108	No	EA12	321
Two-Position SPST	Normally Closed	Figure No. 1 on page 54	120	60	108			322
Floating SPDT	None - Non-Spring Return	None	24	60	24	No	MF-22103	251
							MF-22123	253

^a Refer to the Valve/Actuator Wiring Diagrams in this section.

TABLE 3A. Factory Assemblies (VC-72XX, 92XX), Two-Position SPDT Input, select Actuator Code (XXX). Any EA31 electric gear train actuator can be assembled to valve bodies with the close-off pressure ratings listed in Table 2. Select Actuator Type having sufficient close-off for the application. Select actuator, linkage, valve body and field assemble.

Input Signal	Normal Position	Wiring Figure No. ^a	Voltage	Hz	VA	Aux. Switch	Actuator	Actuator Code (XXX) for Factory Available Assembly
Two-Position SPDT	None (Non-Spring Return)	Figure No. 4 on page 55	120	60	96	Yes	EA31	417
							EA31 w/AV-3532	465 (5 and 6 in. only)

^a Refer to the Valve/Actuator Wiring Diagrams in this section.

TABLE 3B. Factory Assemblies (VP-72XX, 92XX), Multiple Input (refer to Table below), select exact Actuator Code (XXX). Any EA31, EA58 or EA7X electric gear train actuator can be assembled to valve bodies with the close-off pressure ratings listed in Table 2. Select Actuator Type having sufficient close-off for the application. Select actuator, linkage, valve body and field assemble. Refer to Wiring Figures as noted.

Normal Position	Input Signal					Voltage Vac (Hz)	Aux. Switch	Actuator Part Number	Actuator Code (XXX) for Factory Available Assembly
	Current	Slidewire	SPST	SPDT Snap Acting	SPDT Floating Direct Digital Control				
Normally Closed	2	1	3	4	5	120 (60)	Yes	EA42	317
Normally Open			Yes	Yes	Yes			EA44	318
None			—	—	—			EA58	423
Non-Spring Return			—	—	—			EA58 w/AV-351	466
								EA76	952

- Requires 659A ordered separately, refer to Wiring Figure No. 8.
- Requires 658A ordered separately, refer to Wiring Figure No. 9.
- Refer to Wiring Figure No. 2 and Figure No. 3.
- Refer to Wiring Figure No. 5 and Figure No. 6.
- Refer to Wiring Figure No. 7 and Figure No. 9.

TABLE 3C. Factory Assemblies, (VF-72XXM 82XX) MF-631X3, select Actuator Code (XXX). Refer to Table 3D for optional inputs.

Normal Position	Voltage (50/60 Hz)	Aux. Switch	Actuator Part No.	Actuator Code (XXX) for Factory Assembly
None	24	No	MF-63103	301
			MF-63123	303

TABLE 3D. Input Signal for MF-63123. Order these control modules separately.

Input Signal	Control Module (order separately)
	MF-63123
Two-Position, Floating	None (Base Actuator)
4 to 20 mAdc	MFC-420 ^a
6 to 9 Vdc	MFC-8000 ^a

^a Other ranges available by DIP switch setting on module.

Two Way Valves

Screwed, Union Sweat; Electric

TABLE 4. Dimensions in Inches (Millimeters). (Refer to pages 18 through 19 for illustrations.)

Valve Body					Actuator Series (Code)			
Part Number	Size In.	A	B ^a	C	EA12	EA31	EA58	EA76
					E ^b	E	E	E
VB-7213-0-4-P	1/2	3 (76)	4-1/4 (108)	1-7/16 (36)	12-13/16 (325)	13-11/16 (347)	13-11/16 (347)	
	3/4	3-5/8 (92)	5-1/2 (140)	1-7/16 (36)	13-7/16 (351)	14-11/16 (373)	14-11/16 (373)	
VB-7214-0-4-P	1	4-5/8 (117)	6-3/4 (171)	2-1/8 (53)	14-1/8 (358)	15 (380)	15 (380)	
VB-7253-0-4-P	1-1/4		6-7/8 (175)	1-7/8 (48)	13-11/16 (347)	14-9/16 (369)	14-9/16 (369)	
VB-7273-0-4-P	1-1/2	5-3/8 (137)	8-5/8 (219)	1-7/8 (48)	13-3/4 (349)	14-5/8 (371)	14-5/8 (371)	
	2	6-1/8 (156)	9-3/16 (233)		14 (355)	14-7/8 (377)	14-7/8 (377)	
VB-9213-0-4-P	2-1/2	8-1/2 (216)		3-3/4 (95)	16-1/4 (413)	16-1/4 (413)	15-1/4 (387)	
	3	9-1/2 (241)		4-1/4 (108)	16-7/16 (418)	16-7/16 (418)	15-7/16 (392)	
VB-9213-0-5-P	2-1/2	8-1/2 (216)		3-1/2 (89)	16-1/4 (413)	16-1/4 (413)	15-1/4 (387)	
	3	9-1/2 (241)		3-3/4 (95)	16-5/8 (422)	16-5/8 (422)	15-5/8 (397)	
	4	11-1/2 (292)		4-1/2 (114)	17-7/8 (454)	17-7/8 (454)	16-7/8 (429)	23 (584)
	5	13 (330)		5 (127)			18-1/8 (460)	24-1/4 (616)
	6	14 (356)		5-1/2 (140)			18-5/8 (473)	25-1/8 (638)

^a Use B dimension for VB-7214.

^b Subtract 3/4 in. on MA actuators.

TABLE 5. Dimensions in Inches (Millimeters). (Refer to pages 18 through 19 for illustrations.)

Valve Body					Actuator Series (Code)	
Part Number	Size In.	A	B ^b	C	MF-221X3 ^a	MF-631X3
					E	E
VB-7213-0-4-P	1/2	3 (76)	4-1/4 (108)	1-7/16 (36)	4-1/4 (107)	7 (177)
	3/4	3-5/8 (92)	5-1/2 (140)	1-7/16 (36)	5-1/4 (133)	8 (203)
VB-7214-0-4-P	1	4-5/8 (117)	6-3/4 (171)	2-1/8 (53)	5-1/2 (140)	8-5/16 (210)
VB-7253-0-4-P	1-1/4		6-7/8 (175)	1-7/8 (48)	5-1/16 (129)	7-7/8 (199)
VB-7273-0-4-P	1-1/2	5-3/8 (137)	8-5/8 (219)	1-7/8 (48)	4-7/8 (124)	7-15/16 (201)
	2	6-1/8 (156)	9-3/16 (233)		5-7/16 (137)	8-3/16 (207)
VB-9213-0-4-P	2-1/2	8-1/2 (216)		3-3/4 (95)		13-13/16 (351)
	3	9-1/2 (241)		4-1/4 (108)		14-1/16 (357)
VB-9213-0-5-P	2-1/2	8-1/2 (216)		3-1/2 (89)		13-7/8 (352)
	3	9-1/2 (241)		3-3/4 (95)		14-1/4 (362)
	4	11-1/2 (292)		4-1/2 (114)		15-1/2 (394)

^a MF-221X3 for hot water and steam applications only.

^b Use B dimension for VB-7214.

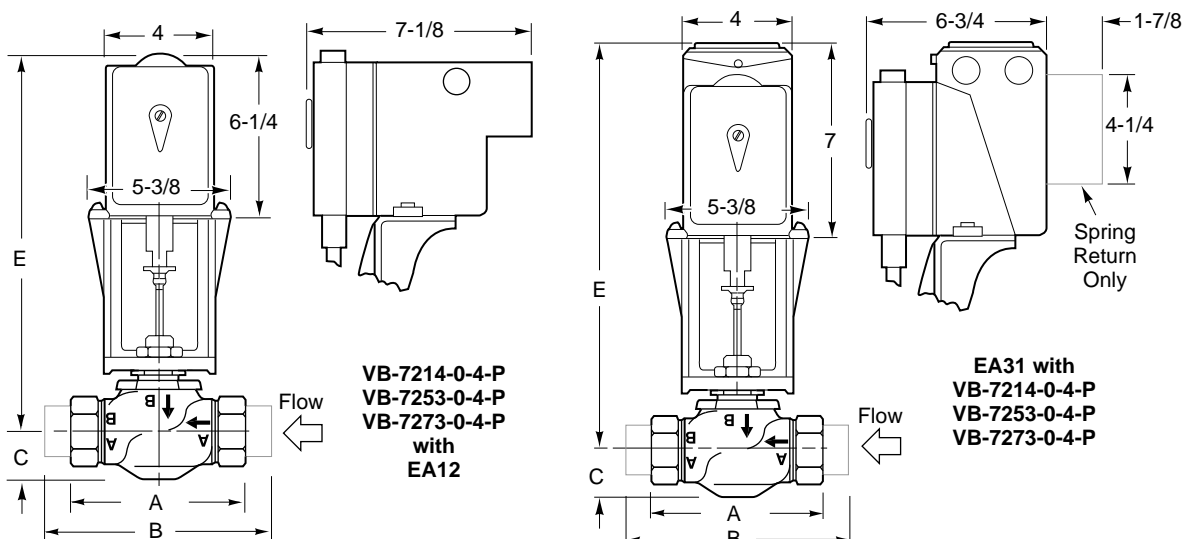

Screwed, Union Sweat; Electric

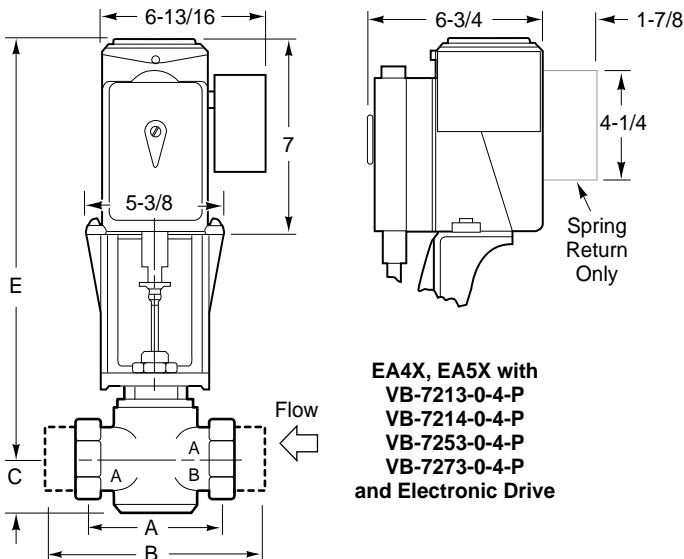
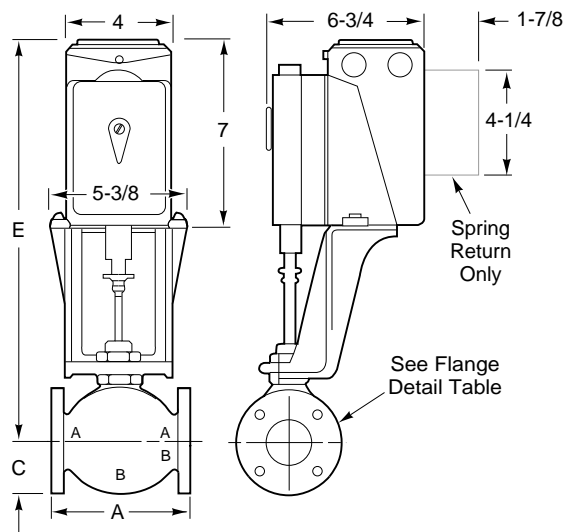
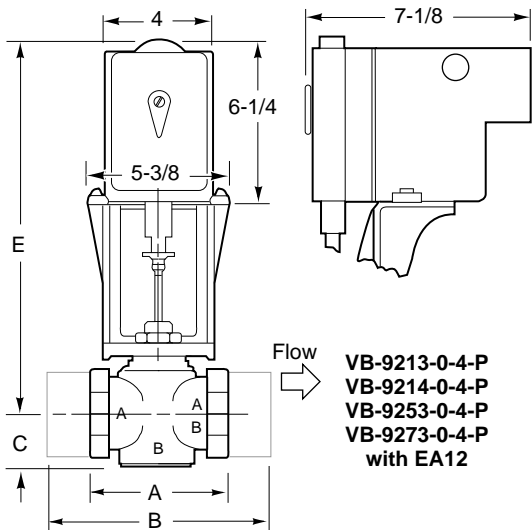
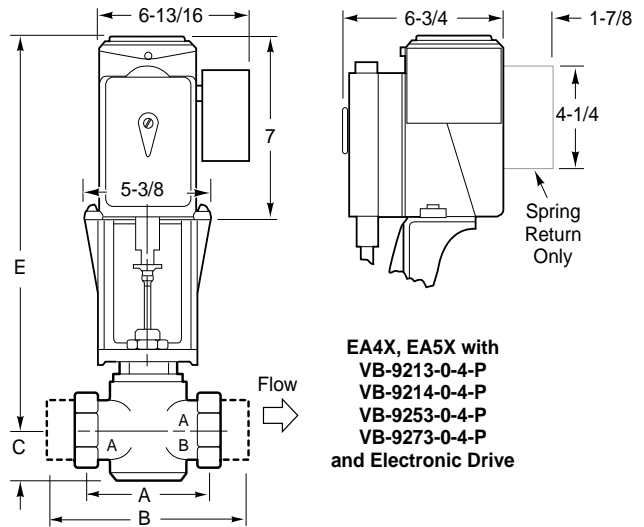
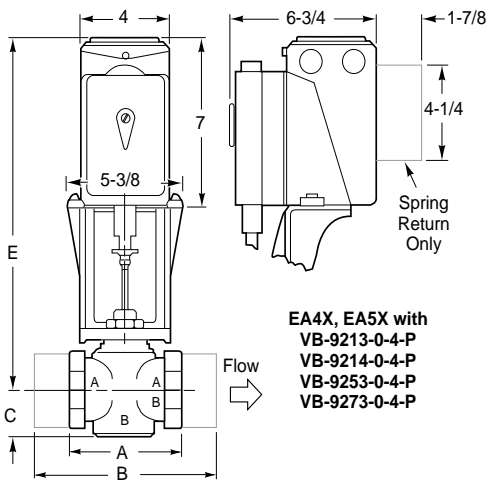

Two Way
 Valves

Screwed, Union Sweat; Electric

Two Way Valves

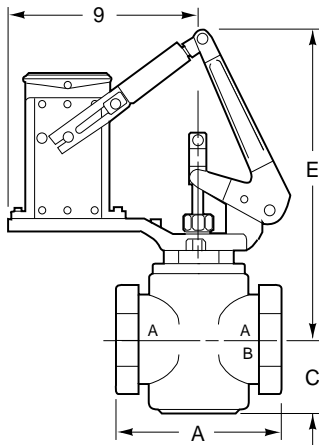

EA58 with
VB-9213-0-4-P
(2-1/2"-3") and
AV-352 Linkage

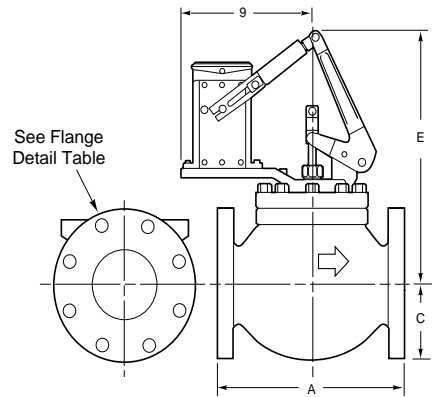

EA58 with
VB-9213-0-5-P
and AV-352 Linkage

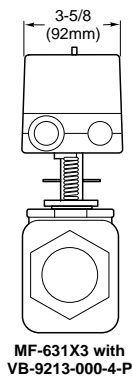
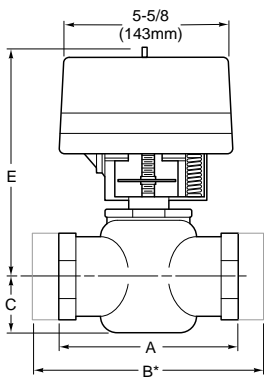

MF-631X3 with
VB-9213-000-4-P

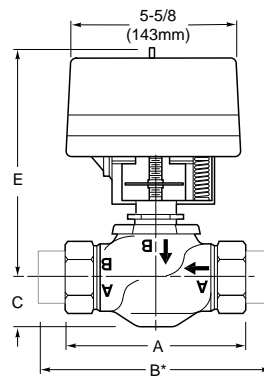

* For VB-7214

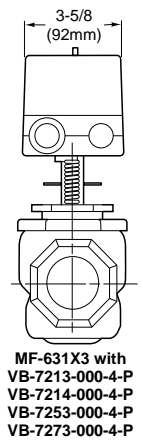

MF-631X3 with
VB-7213-000-4-P
VB-7214-000-4-P
VB-7253-000-4-P
VB-7273-000-4-P

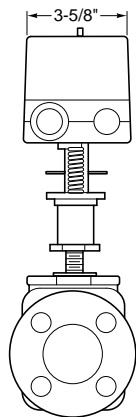
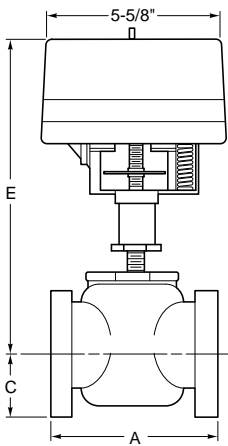

MF-631X3 with
VB-9213-000-5-P

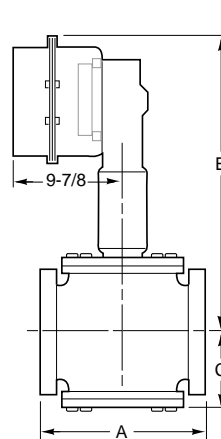

EA76 with
VB-9213-0-5-P

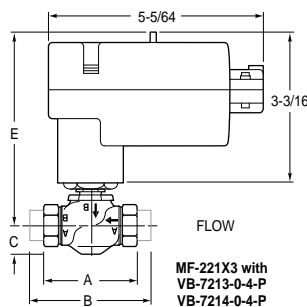
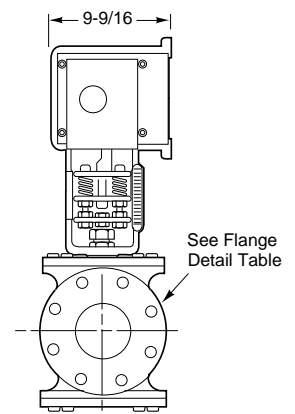

MF-221X3 with
VB-7213-0-4-P
VB-7214-0-4-P

Screwed, Union Sweat; Electric

American Standard 125 lb. Cast Iron Pipe Flanges.

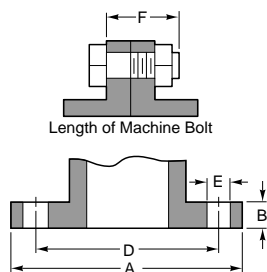

Flange Detail Dimensions in Inches (Metric conversion 25.4 mm = 1 in.).

Nominal Pipe Size	Flanges		Drilling		Bolting		Length of Machine Bolts F
	Flange Diameter A	Flange Thickness B	Diameter of Bolt Circle D	Diameter of Bolt Holes E	Number of Bolts	Diameter of Bolts	
2-1/2	7	11/16	5-1/2	3/4	4	5/8	2-1/2
3	7-1/2	3/4	6	3/4	4	5/8	2-1/2
4	9	15/16	7-1/2	3/4	8	5/8	3
5	10	15/16	8-1/2	7/8	8	3/4	3
6	11	1	9-1/2	7/8	8	3/4	3-1/4

Two Way Valves

TABLE 6. Restrictions on Max. Ambient Temperature for Valve Actuators.

Actuator Code (XXX)	Temperatures °F (°C)						
	EA12 EA4X	EA31 EA58	EA76	251	253	301	303
				MF-22103 ^a	MF-22123 ^a	MF-63103	MF-63123
Maximum Ambient	136 (57)	136 (57)	130 (54)	140 (60)		140 (60)	
Max. Allowable Fluid	260 (126)	260 (126)	260 (126)	220 (104)	200 (93)	260 (126)	
VB-7213-0-4-P VB-7214-0-4-P VB-9213-0-4-P VB-9213-0-5-P	Max. Fluid	281 (138)	281 (138)	281 (138)	281 (138)		281 (138)
	Max. Allow. Ambient	125 (52)	125 (52)	125 (52)	115 (46)		125 (52)
VB-7273-0-4-P	Max. Fluid	366 (183)	—	—	366 (183)		340 (171)
	Max. Allow. Ambient	100 (38)			100 (38)		100 (38)
VB-7253-0-4-P	Max. Fluid	340 (171)	—	—	340 (171)		366 (185)
	Max. Allow. Ambient	100 (38)			100 (38)		100 (38)

^a MF-221X3 for hot water and steam applications only.

High Temp; Electric

TABLE 1. Select Valve Body including P Code (Valve Size, CV Rating, Port Code) or select Valve Assembly with correct Input Signal (refer to Table 2A also) less Actuator Code (XXX) including the P Code (Size, Cv Rating, Port Code). (Refer to Pages 46 to 51 for Valve Sizing.)

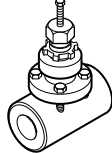
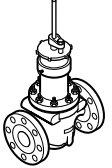
		Application	
		High Temperature Water High Pressure Steam	
		Screwed	Flanged
			
Size		1/2 to 1-1/2 in.	1 to 1-1/2 in.
Valve Body (Stem Down to Close) Actuator Provides Normal Position		VB-222-0-1-P	VB-222-0-2-P
Normal Position	Actuator Series	Input Signal(s)	
Normally Open or Closed (Refer to Table 2A)	EA42, EA44	(Refer to Table 2A)	
No Normal Position (Non-Spring Return) (Refer to Table 2A)	EA58	(Refer to Table 2A)	
		Factory Available Valve Assembly	
		VP-2224-XXX-1-P	VP-2224-XXX-2-P
		VP-2224-XXX-1-P	VP-2224-XXX-2-P
		Flow Type	Equal %
		Equal %	Equal %
Material	Body	Steel	Steel
	Seat	Stainless Steel	Stainless Steel
	Stem	Stainless Steel	Stainless Steel
	Plug	Stainless Steel	Stainless Steel
	Packing	TFE "V" Rings	TFE "V" Rings
	Disc	None	None
STEAM			
Pressure psig (kPa)	Static	600 (4137)	300 (2069)
	Inlet	400 (2758)	300 (2069)
	Recommended Differential ^a	100 (690)	100 (690)
Fluid Temp. °F (°C)	Max.	446 (230)	420 (216)
WATER			
Pressure psig (kPa)	Static	600 (4137)	300 (2069)
	Recommended Differential ^a	100 (690)	100 (690)
Fluid Temp. °F (°C)	Min.	40 (4)	40 (4)
	Max.	450 (232)	400 (204)

NOTE: It is possible to select either a valve assembly or component parts (actuator, valve linkage, valve body).

ORDERING EXAMPLES:

1. Valve Assembly: . . VP-2224-318-1-8

2. Valve Body: VB-222-0-1-8

Actuator: EA44

Linkage: AV-347-20

- Valve Body Data less P Code (Size, CV Rating, Port Code) or Valve Assembly less Actuator Code (XXX) and less P Code (Size, CV Rating, Port Code)
- P Code (Size, Cv Rating, Port Code)
- Actuator or Actuator Code (XXX) for Valve Assemblies
- Valve Linkage

TO SELECT A PORT CODE (P).

P Code	Valve Size (in.) ^b	Cv	
-1	1/2	.95	
-2		1.4	
-3		2.5	
-5	3/4	4.0	
-6		9.0	
-7	1	7.4	
-8		17.2	17.2
-10	1-1/2	35.8	35.8

^a CAUTION: Maximum recommended differential pressure in full open position. Do not exceed recommended differential pressure (pressure drop) or integrity of parts may be affected. Do not exceed close-off rating.

^b CAUTION: Fittings and/or pipe schedules must meet or exceed working static pressure requirements.

High Temp; Electric

TABLE 2. Select Actuator Type or Actuator Code (XXX) series with correct Input Signal having sufficient close-off for the application. If selecting Component Parts, select Valve Linkage.

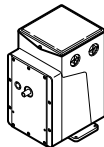
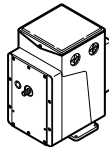
							
Input Signal				Refer to Table 2A	Refer to Table 2A		
Valve Linkage		Body Style A		AV-347	AV-347-10		
		Body Style B		AV-347-20	AV-347-30		
Actuator Types				Spring Return EA42, EA44	Non-Spring Return EA58		
Actuator Code (XXX)					101, 103		
Spring Range (psig)				—	—		
CLOSE-OFF PRESSURE RATING (psi)^a							
Factory Available Valve Assemblies	Valve Body	StyleA	P Code	Size (in.)			
VP-2224-XXX-1-P	VB-222-0-1-P	A	-1-2-3	1/2	600	600	
			B	-6			3/4
		B	A	-7	1	600	600
			B	-8			
			B	-10			
VP-2224-XXX-2-P	VB-222-0-2-P	B	-8	1	300	300	
			-10	1-1/2			

^a Close-off pressure ratings apply when valves are installed with pressure under the seat. Close-off ratings for Pneumatic actuators in the table are true only when the indicated supply air pressure is applied to the actuator. A change in air pressure at the actuator alters the actual close-off pressure.

TABLE 2A. Factory Assemblies (VP-2224), Multiple Input (refer to table below) select exact Actuator Code (XXX). Any MP-3XX or 4XX electric gear train actuator can be assembled to valve bodies with the close-off pressure ratings listed in Table 2. Select Actuator Type having sufficient close-off for the application. Select actuator, linkage, valve body and field assemble. Refer to Wiring Figures as noted.

Normal Position	4 to 20 mA etc.	Slidewire	SPST	SPDT Snap Acting	SPDT Floating Direct Digital Control	Voltage Vac (Hz)	Aux. Switch	Actuator Part Number	Actuator Code (XXX) for Factory Available Assembly
		1	5	6	6				
Normally Closed	9	2	Yes	Yes	Yes	120 (60)	Yes	EA44	318
	4, 10	2							
None (Non-Spring Return)	9	2	—	Yes	Yes	120 (60)	Yes	EA58	317
	4, 10	2	—						

- Requires 659A ordered separately, refer to Wiring Figure No. 8.
- Requires 658A ordered separately, refer to Wiring Figure No. 9.
- Refer to Wiring Figure No. 2 and Figure No. 3.
- Refer to Wiring Figure No. 5.
- Refer to Wiring Figure No. 7.
- Requires 658A ordered separately..

Two Way Valves

High Temp; Electric

TABLE 3. Dimensions in Inches (Millimeters).

Valve Body					Actuator Series
Part Number	Body Style	Size (in.)	A	C	MP-3XX, 4XX, MP-4XX-600
VB-222-0-1-P VB-222-0-2-P	A	1/2	4 (102)	1-3/8 (35)	16-3/8 (416)
	A	3/4	4-1/8 (105)	1-3/8 (35)	16-3/8 (416)
	B	3/4	6-1/2 (165)	2-1/8 (54)	16-7/8 (429)
	A	1	5 (127)	1-1/2 (38)	16-3/8 (416)
	B	1	8-1/4 (210)	2-3/8 (60)	16-5/8 (422)
	B	1-1/2	9-7/8 ^a (251)	2-7/8 (73)	16-1/8 (403)

^a 9-3/4 for flanged body.

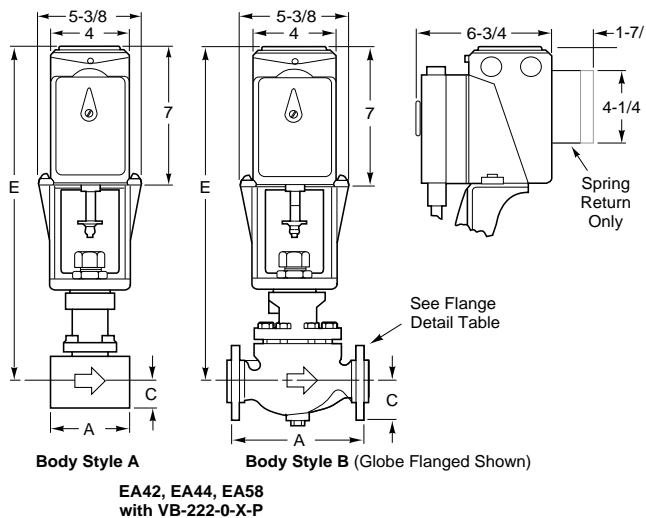

ASA Steel Flanges.

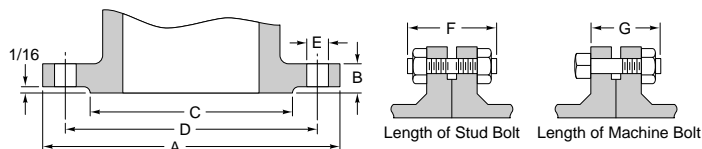

Flange Detail Dimensions in Inches (Metric conversion 25.4 mm = 1 in.).

Nominal Pipe Size	Flange Diameter A	Flange Thickness B	Diameter of Raised Face C	Diameter of Bolt Circle D	Diameter of Bolt Holes E	Number of Bolts	Diameter of Bolts	Length of Stud Bolts with Two Nuts F	Length of Machine Bolts G
1	4-7/8	11/16	2	3-1/2	3/4	4	5/8	3	2-1/2
1-1/2	6-1/8	13/16	2-7/8	4-1/2	7/8		3/4	3-1/2	3

TABLE 4. Restrictions on Maximum Ambient Temperature for Valve Actuators.

Temperatures °F (°C)		
Actuator Series	EA42, EA44, EA58	
Valve Assemblies	VP-2224-XXX	
Maximum Ambient	136 (57)	
Max. Allowable Fluid	260 (126)	
VB-222-0-1-P	Max. Fluid	450 (232)
	Max. Allw. Amb.	80 (27)
VB-222-0-2-P	Max. Fluid	400 (204)
	Max. Allw. Amb.	90 (32)

Mixing, Sequencing; Flared

TABLE 1. Select Valve Body including P Code (Valve Size, Cv Rating, Port Code) or select Valve Assembly with correct Input Signal (refer to Table 3 and Table 3A also) less Actuator Code (XXX) including the P Code (Size, Cv Rating, Port Code). (Refer to Pages 46 to 51 for Valve Sizing.)

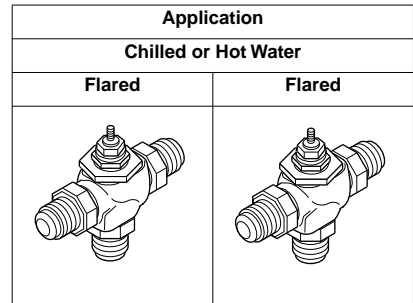

NOTE: It is possible to select either a valve assembly or component parts (actuator, valve linkage, valve body).

1. **Valve Assembly . . . VS-7312-68-4-2**
 2. **Valve Body VB-7312-0-4-2**
Actuator EA58
Linkage AV-600
- Valve Body Data less P Code (Size, Cv Rating, Port Code) or Valve Assembly less Actuator Code (XXX) and less P Code (Size, Cv Rating, Port Code)
 - P Code (Size, Cv Rating, Port Code)
 - Actuator or Actuator Code (XXX) for Valve Assemblies
 - Valve Linkage

Size	5/8 in. O.D., SAE 45°	5/8 in. O.D., SAE 45°	
Valve Body	VB-7312-0-4-P	VB-7332-0-4-P	
Valve Assembly Floating SPDT	VF-7312-2XX-4-P	—	
Valve Assembly 4 to 20 mA, 135 Ohm	VS-7312-2XX-4-P	VS-7332-2XX-4-P	
	Flow Type	Mixing	Sequencing
Material	Body	Bronze	Bronze
	Seat	Bronze	Bronze
	Stem	Stainless Steel	Stainless Steel
	Plug	Brass	Brass
	Packing	Spring Loaded TFE	Spring Loaded TFE
	Disc	None	None
	ANSI Pressure Class (psig)^a	250 (Refer to page 42)	
	Allowable Control Media Temp^b	20 to 281°F (-7 to 138°C)	20 to 281°F (-7 to 138°C)
	Allowable Differential Pressure for Water psig (kPa)	35 psi (241) max. for normal life (See page 46 for cavitation limits)	

TO SELECT A PORT CODE (P).

P Code	Valve Size in. ^c	Cv	
-2 ^c	1/2 or 5/8	2.2	1.3
-3			2.2
-4		4.4	4.4

^a CAUTION: Fittings and/or pipe schedules must meet or exceed working static pressure requirements.
^b CAUTION: Freeze protection required for temperatures below 32°F (0°C). Do not use Hydraulic Actuators with fluid temperatures below 40°F (4°C).
^c Factory assemblies are not available for two-position applications using reduced port valve bodies.

Mixing, Sequencing; Flared

TABLE 2. SPST, select Actuator Type or Actuator Code (XXX) with correct Input Signal having sufficient close-off for the application. If selecting Component Parts, select Valve Linkage.

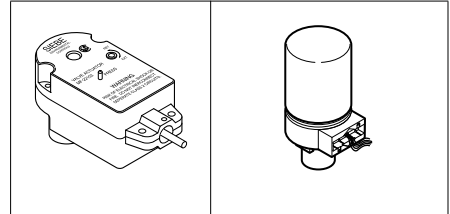

		Input Signal		Floating DDC or SPDT		4 - 20 mA; 135 Ω		
		Valve Linkage		AV-640 (Included)		AV-600 ^a		
		Actuator Type		MF-22103 ^b MF-22123 ^b		EA81		
		Actuator Code (XXX)		25X		268, 278		
Normal Position	Factory Available Valve Assembly	Valve Body	P Code	Size in.	CLOSE -OFF PRESSURE RATING (psi) ^c			
					SU ^c	SD ^c	SU ^d	SD ^d
Stem Up Flow "B" to "AB"	VF-7312-22X-4-P VS-7332-2XX-4-P	VB-7312-0-4-P	-2-4	5/8	101	118	110	100
Stem Up Flow "B" to "AB"	VS-7332-2XX-4-P	VB-7332-0-4-P	-2-3-4		—	—	42 ^e	45 ^e

^a MP-541X, MPR-561X, MPR-571X, and MPR-581X use AV-600 and AV-601.

^b MF-221X3 for hot water and steam applications only.

^c Close-off ratings for mixing or sequencing valves; (SU = "A" port, SD = "B" port). "A" port (SU) ratings equal pressure at port "A" minus pressure at port "B"; "B" port (SD) ratings equal pressure at port "B" minus pressure at port "A".

^d SU — Stem Up; SD — Stem Down. Refer to Table 5 for flow pattern, port designations and normal position.

^e 35 psi in neutral position (both ports closed).

Mixing, Sequencing; Flared

TABLE 3. Factory Assemblies (135 Ω, 4 to 20 mA), select exact Actuator Code (XXX). Any EA81 can be assembled to 1/2 in. to 1-1/4 in. valve bodies with the close-off pressure ratings listed in Table 2 and Table 2A. Select below listed Hydraulic Actuators or Actuator Codes (XXX) for factory available assemblies. For applications that factory assemblies are not available, select actuator, linkage, body and field assemble.

Input Signal	Wiring Figure No. ^a	Voltage Vac 50/60 Hz	VA	Aux. Switch	Actuator Part No.	Actuator Code (XXX) for Factory Available Assembly		
						VA-7312	VS-7312, 7332	VF-7312
4 to 20 mA	Figure 10 on page 57	24	18		MPR-5613	—	267 ^b	
		120			MPR-5610	—	264 ^b	
		240			MPR-5611	—	265 ^b	

^a Refer to the Valve/Actuator Wiring Diagrams in this section.

NOTE: Allow 3 inches clearance above actuator for removal.

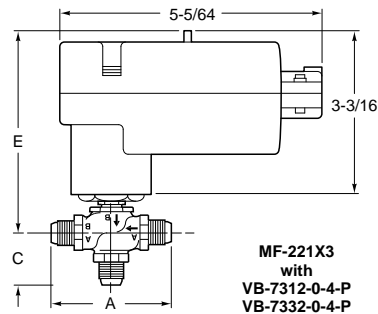
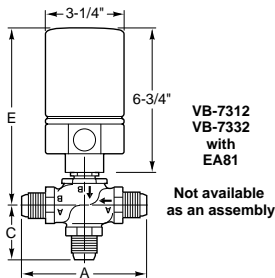

^a AV-601 linkage extension (not shown) required for hot water applications. Refer to Tab...

TABLE 4. Dimensions in Inches (Millimeters).

Valve Body				Valve Assembly (Actuator Type)	
Part Number Series	Size (in.)	A	C	VA-7312-2X1, VS-73X2-2X1	
				E	
VB-7312	5/8	4 (102)	1-7/16 (36)	7-13/16 (197)	
VB-7332					

TABLE 5. Flow Pattern.

Body Part Number	Flow Type	Stem Up (SU) (Normal Position)		Stem Down (SD)	
		Flow	Closed Port	Flow	Closed Port
VB-7312-0-4-P	Mixing	B to AB	A	A to AB	B
VB-7332-0-4-P	Sequencing	B to AB	A	A to AB	B

TABLE 6. Restrictions on Maximum Ambient Temperature for Valve Actuators.

Temperatures °F (°C)				
		MF-22103	MF-22123	EA81
Maximum Ambient		140 (60)	140 (60)	140 (60)
Max. Allowable Fluid		220 (101)	220 (101)	140 (60)
VB-7312-0-4-P VB-7332-0-4-P	Maximum Fluid	281 (138)	281 (138)	281 (138)
	Max. Allw. Ambient	115 (46)	115 (38)	103 (39)

CAUTION: Avoid condensation which can facilitate corrosion. With 40°F (4°C) water, the maximum allowable ambient dew point temperature is 68°F (20°C). Piping insulation must not stop drainage at actuator mounting nut. Do not use Hydraulic Actuators with fluid temperatures below 40°F (4°C).

Three Way Valves

Mixing, Diverting; Hydraulic

TABLE 1. Select Valve Body including P Code (Valve Size, Cv Rating, Port Code) or select Valve Assembly with correct Input Signal (refer to Table 3 also) less Actuator Code (XXX) including the P Code (Size, Cv Rating, Port Code). (Refer to Pages 46 to 51 for Valve Sizing.)

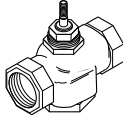
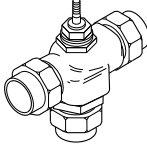
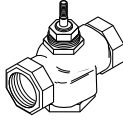
		Application			
		Chilled or Hot Water			
		Screwed NPT	Union Sweat	Screwed NPT	
					
Size		1/2 to 1-1/4 in.	1/2 to 1-1/4 in. I.D.	1/2 to 1-1/4 in.	
Valve Body		VB-7313-0-4-P	VB-7314-0-4-P	VB-7323-0-4-P	
Valve Assembly 2 to 15 Vdc, System 8000, 4 to 20 mA		VS-7313-XXX-4-P	—	VS-7323-XXX-4-P	
Normal Position		Stem Up Flow "B" to "AB"	Stem Up Flow "B" to "AB"	Stem Up Flow "B" to "AB"	
NOTE: It is possible to select either a valve assembly or component parts (actuator, valve linkage, valve body).	Flow Type	Mixing	Mixing	Diverting	
	Material	Body	Bronze	Bronze	Bronze
		Seat	Bronze	Bronze	Bronze
		Stem	Stainless Steel	Stainless Steel	Stainless Steel
		Plug	Brass	Brass	Stainless Steel
		Packing	Spring Loaded TFE	Spring Loaded TFE	Spring Loaded TFE
		Disc	None	None	None
ANSI Pressure Class (psig) ^a	250 (up to 400 psig below 150°F, see page 42)				
Allowable Control Media Temp ^b	20 to 281°F (-7 to 138°C)				
Allowable Differential Pressure for Water psig (kPa)	35 psi (241) maximum for normal life (Refer to page 46 for cavitation limits)		35 (241)		

ORDERING EXAMPLES:

- Valve Assembly:**
VS-7313-268-4-6
 - Valve Body:**
VB-7313-0-4-6
Actuator:EA81
Linkage: AV-600 and AV-601
- Valve Body Data less P Code (Size, Cv Rating, Port Code) or Valve Assembly less Actuator Code (XXX) and less P Code (Size, Cv Rating, Port Code)
- P Code (Size, Cv Rating, Port Code)
- Actuator or Actuator Code (XXX) for Valve Assemblies
- Valve Linkage

TO SELECT A PORT CODE (P).

P Code	Valve Size in. ^a	Cv		
-2 ^c	1/2	2.2	2.2	
-4		4.4	4.4	6
-6	3/4	8	8	8
-8	1	14	14	14
-9	1-1/4	20	20	20

^a CAUTION: Solder, tubing and/or pipe schedules must meet or exceed working static pressure requirements.

^b CAUTION: Freeze protection required for fluid temperatures below 32°F (0°C). Do not use Hydraulic Actuators with fluid temperatures below 40°F (4°C).

^c Factory assemblies are not available for two-position applications using reduced port valve bodies.

Mixing, Diverting; Hydraulic

TABLE 2. Select Actuator Type or Actuator Code (XXX) series with correct Input Signal having sufficient close-off for the application. If selecting Component Parts, select Valve Linkage.

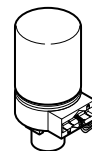

Valve Linkage (1/2 to 1-1/4 in.)				AV-7600	
Input Signal				4 to 20 mA, 135 Ω	
Actuator Code (XXX)				2XX	
Actuator Type				EA81	
Factory Available Valve Assemblies	Valve Body	P Code	Size (in.)	SU ^c	SD ^c
VS-7313-XXX-4-P	VB-7313-0-4-P VB-7314-0-4-P	-2-4	1/2	55	80
		-6	3/4	35	50
		-8	1	25	30
		-9	1-1/4	15	20
		-10	1-1/2	10	15
VA-7323-XXX-4-P VS-7323-XXX-4-P	VB-7323-0-4-P	-11	2	6	10
		-4	1/2	250	250
		-6	3/4	250	250
		-8	1	250	250
		-9	1-1/4	250	250

TABLE 3. Factory Assemblies, select exact Actuator Code (XXX). Any EA81 can be assembled to 1/2 to 1-1/4 in. valve bodies with the close-off pressure ratings listed in Table 2. Select below listed Hydraulic Actuators or Actuator Codes (XXX) for factory available assemblies. For applications that factory assemblies are not available, select actuator, linkage, valve body and field assemble.

Input Signal	Wiring Figure No. ^a	Voltage Vac 50/60 Hz	VA	Actuator Part No.	Actuator Code (XXX) for Factory Available Assembly
					VS-73X3
4 to 20 mA	Figure 10 on page 57	120	18	EA81-11006	268
135 Ω				EA81-17006	278

^a Refer to the Valve/Actuator Wiring Diagrams in this section.

Mixing, Diverting; Hydraulic

TABLE 4. Dimensions in Inches (Millimeters).

Valve Body						Actuator Series
						EA81
Part Number	Size (in.)	A	B ^a	C	D ^a	E
VB-7313-0-4-P	1/2	3 (76)	4-1/4 (108)	1-7/16 (36)	2-7/8 (73)	7-13/16 (197)
VB-7314-0-4-P	3/4	3-5/8 (92)	5-1/2 (140)	1-7/16 (36)	3-3/16 (80)	8-13/16 (223)
VB-7323-0-4-P	1	4-5/8 (117)	6-3/4 (171)	2-1/8 (53)	3-7/8 (98)	9-1/16 (230)
	1-1/4		6-7/8 (175)	1-5/8 (42)	3-7/8 (89)	8-5/16 (210)

^a Use B and D dimensions for VB-7314 valve body.

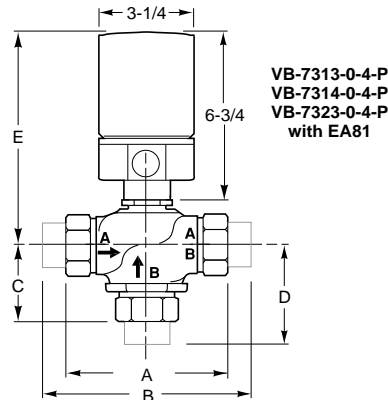

^a AV-601 linkage extension (not shown) required for hot water applications. Refer to Table 3.

TABLE 5. Flow Pattern.

Part Number	Flow Type	Stem Up (SU) (Normal Position)		Stem Down (SD)	
		Flow	Closed Port	Flow	Closed Port
VB-7313-0-4-P	Mixing	B to AB	A	A to AB	B
VB-7314-0-4-P		B to AB	A	B to A	AB
VB-7323-0-4-P	Diverting	B to AB	A	B to A	AB

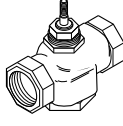
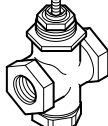
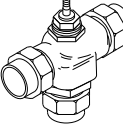

TABLE 6. Restrictions on Maximum Ambient Temperature for Valve Actuators.

Temperatures °F (°C)		
Actuator Code (XXX)	268, 278	
Actuator Types	EA81	
Maximum Ambient	140 (60)	
Max. Allowable Fluid		
VB-7313-0-4-P	Maximum Fluid	281 (138)
VB-7314-0-4-P	Max. Allw. Ambient	103 (39)
VB-7323-0-4-P		

CAUTION: Avoid condensation which can facilitate corrosion. With 40°F (4°C) water, the maximum allowable ambient dew point temperature is 68°F (20°C). Piping insulation must not stop drainage at actuator mounting nut. Do not use Hydraulic Actuators with fluid temperatures below 40°F (4°C).

Mixing, Diverting; Electric

x
TABLE 1. Select Valve Body including P Code (Valve Size, CV Rating, Port Code) or select Valve Assembly with correct Input Signal (refer to Table 3A also) less Actuator Code (XXX) including the P Code (Size, Cv Rating, Port Code). (Refer to Pages 46 to 51 for Valve Sizing.)

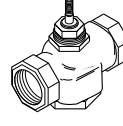
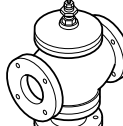
		Application					
		Chilled or Hot Water					
		Screwed NPT	Screwed NPT	Union Sweat	Flanged	Screwed NPT	Flanged
							
Size		1/2 to 2 in.	2-1/2 & 3 in.	1/2 to 2 in. I.D.	2-1/2 to 6 in.	1/2 to 2 in.	2-1/2 to 6 in.
Valve Body, Actuator Provides Normal Position ^a		VB-7313-0-4-P	VB-9313-0-4-P	VB-7314-0-4-P	VB-9313-0-5-P	VB-7323-0-4-P	VB-9323-0-5-P
Actuator Types		Factory Available Valve Assemblies					
Input Signal							
EA12	SPST (Refer to Table 3)	VA-7313-XXX-4-P	VA-9313-XXX-4-P	VA-7314-XXX-4-P	—	VA-7323-XXX-4-P	—
EA31	SPDT (Refer to Table 3)	VC-7313-XXX-4-P	VC-9313-XXX-4-P	VC-7314-XXX-4-P	VC-9313-XXX-5-P	VC-7323-XXX-4-P	VC-9323-XXX-5-P
MF-221X3 ^b , MF-631X3	Floating SPDT Multiple Input (Refer to Table 3C)	VF-7313-25X-4-P	VF-9313-30X-4-P	—	VF-9313-30X-5-P	—	—
EA42, EA44, EA58, EA76	(Refer to Table 3A)	VP-7313-XXX-4-P	VP-9313-XXX-4-P	VP-7314-XXX-4-P	VP-9313-XXX-5-P	VP-7323-XXX-4-P	VP-9323-XXX-5-P
Flow Type		Mixing	Mixing	Mixing	Mixing	Diverting	Diverting
Material	Body	Bronze	Bronze	Bronze	Iron	Bronze	Iron
	Seat	Bronze	Bronze	Bronze	Bronze	Bronze	Bronze
	Stem	Stainless Steel	Stainless Steel	Stainless Steel	Stainless Steel	Stainless Steel	Stainless Steel
	Plug	Brass	Brass	Brass	Brass	Stainless Steel	Bronze
	Packing	Spring Loaded TFE	Spring Loaded TFE	Spring Loaded TFE	Spring Loaded TFE	Spring Loaded TFE	Grafoil
	Disc	None	None	None	None	None	None
ANSI Pressure Class ^c (psig) Refer to page 42		250 (up to 400 psig below 150°F)			125 (200 psig below 150°F)	250 (up to 400 psig below 150°F)	125 (200 psig below 150°F)
Allowable Control Media Temp ^d		20 to 281°F (-7 to 138°C)	40 to 300°F (4 to 149°C)	20 to 281°F (-7 to 138°C)	40 to 300°F (4 to 149°C)	20 to 281°F (-7 to 138°C)	40 to 300°F (4 to 149°C)
Allowable Differential Pressure for Water psig (kPa)		35 psi (241)Max. for normal life (Refer to page 46 for cavitation limits)					

NOTE: It is possible to select either a valve assembly or component parts (actuator, valve linkage, valve body).

ORDERING EXAMPLES:

1. **Valve Assembly:**
VP-7313-317-4-10

2. **Valve Body:**
VB-7313-0-4-10
Actuator: EA42
Linkage: AV-392

- Valve Body Data less P Code (Size, Cv Rating, Port Code) or Valve Assembly less Actuator Code (XXX) and less P Code (Size, Cv Rating, Port Code)
- P Code (Size, Cv Rating, Port Code)
- Actuator or Actuator Code (XXX) for Valve Assemblies
- Valve Linkage

TO SELECT A PORT CODE (P).

P Code	Valve Size ^e in.	Cv						Port	
-2 ^e	1/2	2.2		2.2					
-4		4.4		4.4		6			
-6	3/4	7.0		7.0		8			—
-8	1	14	—	14	—	14			
-9	1-1/4	20		20		20			
-10	1-1/2	30		30		30			
-11	2	40		40		40			
-12	2-1/2		67		74			68	75
-13	3		91		101			85	95
-14	4	—		—	170	—		160	180
-15	5				290			195	220
-16	6				390			250	275

^a Refer to Table 3 and Table 6 for flow pattern, port designations, and normal position.

^b MF-221X3 for hot water and steam applications only.

^c CAUTION: Solder, tubing and/or pipe schedules must meet or exceed working static pressure requirements.

^d CAUTION: Freeze protection required for fluid temperatures below 32°F (0°C).

^e Factory assemblies are not available for two-position application using reduced port valve bodies.

Three Way Valves

Mixing, Diverting; Electric

TABLE 2. Select Actuator Type or Actuator Code (XXX) series with correct Input Signal having sufficient close-off for the application. If selecting Component Parts, select Valve Linkage.

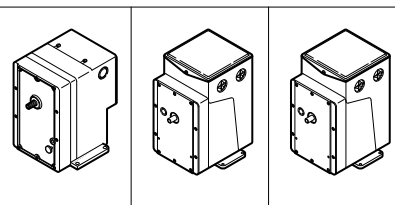

Input Signal				Two-Position SPST		Refer to Table 3 and Table 3A			
Valve Linkage VB-7313, VB-7314, VB-9313 and VB-9314				1/2 to 1-1/4 in.	AV-391	AV-393		AV-352	
				1-1/2 to 2 in.	AV-391	AV-393			
				2-1/2 to 4 in.	AV-395	AV-396			
				5 to 6 in.					
Valve Linkage VB-7323 and VB-9323				1/2 to 1-1/4 in.	AV-391	AV-393			
				1-1/2 to 2 in.	AV-391	AV-393			
				2-1/2 to 3 in.	AV-300 and AV-29	AV-300 and AV-30			
				4 to 6 in.		AV-352			
Normal Position				Refer to Table 3		None		None	
Actuator Code (XXX)				317, 321, 322		417, 423		465, 466	
Actuator Types				EA12, EA4X		EA31, EA58			
Valve Assembly	Valve Body	P Code	Size in.	CLOSE-OFF PRESSURE RATING (psi) ^{a b}					
				SU	SD	SU	SD	SU	SD
VA-731X-3XX-4-P VC-731X-4XX-4-P VP-731X-XXX-4-P	VB-7313-0-4-P VB-7314-0-4-P	-2-4	1/2	250	250	250	250		
		-6	3/4	220	200				
		-8	1	150	140				
		-9	1-1/4	100	95	200	190		
		-10	1-1/2	60	60	140	130		
		-11	2	33	33	80	75		
VA-9313-3XX-4-P VC-9313-4XX-4-P VP-9313-XXX-4-P	VB-9313-0-4-P	-12	2-1/2	20	20	50	50	112	112
		-13	3	12	12	34	34	77	77
VA-9313-3XX-5-P VC-9313-4XX-5-P VP-9313-XXX-5-P	VB-9313-0-5-P	-12	2-1/2	20	20	50	50	112	112
		-13	3	12	12	34	34	77	77
		-14	4	6	6	17	17	42	42
		-15	5					18	18
		-16	6					11	11
VA-7323-3XX-4-P VC-7323-4XX-4-P VP-7323-XXX-4-P VS-7323-XXX-4-P	VB-7323-0-4-P	-4	1/2	250	250	250	250		
		-6	3/4						
		-8	1						
		-9	1-1/4						
		-10	1-1/2						
		-11	2						
VC-9323-4XX-5-P VP-9323-XXX-5-P	VB-9323-0-5-P	-12	2-1/2	125	125	125	125		
		-13	3						
		-14	4						
		-15	5						
		-16	6						

^a Close-off ratings for mixing or sequencing valves: (SU = "A" port, SD = "B" port). "A" port (SU) ratings equal pressure at port "A" minus pressure at port "B". "B" port (SD) ratings equal pressure at port "B" minus pressure at port "A".

^b SU — Stem Up; SD — Stem Down. Refer to Table 3 and Table 6 for flow pattern, port designations, and normal position.

Mixing, Diverting; Electric

TABLE 2A. Select Actuator Type or Actuator Code (XXX) series with correct Input Signal having sufficient close-off for the application. If selecting Component Parts, select Valve Linkage.

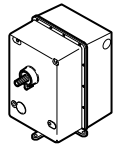
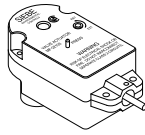
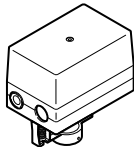
									
Input Signal				Refer to Table 3A	Floating SPDT	Floating SPDT and Multiple Input			
Valve Linkage for VB-7313		1/2 to 1-1/4 in.		—	AV-640 (Included)		AV-671 (included)		
		1-1/2 to 2 in.		—	AV-640 (Included)		AV-671 (Included)		
Valve Linkage for VB-9313		2-1/2 to 4 in.		—	—		AV-671		
		5 to 6 in.		AV-358	—		—		
Valve Linkage VB-7314 and VB-9314		1/2 to 1-1/4 in.		—	—		—		
		1-1/2 to 2		—	—		—		
Valve Linkage VB-7323		1/2 to 1-1/4 in.		—	AV-640 (Included)		AV-672		
		1-1/2 to 2 in.		—	—		—		
Normal Position				None	—		—		
Actuator Code (XXX)				952	251	253	301	303	
Actuator Types				EA76	MF-22103 ^a	MF-22123 ^a	MF-63103	MF-63123	
Valve Assembly	Valve Body	P Code	Size in.	CLOSE-OFF PRESSURE RATING^{b c} (psi)					
				SD	SU	SU	SD	SD	SU
VF-7313-25X-4-P	VB-7313-0-4-P VB-7314-0-4-P	-2-4	1/2 or 5/8			101	118	250	250
		-6	3/4			55	59		
		-8	1			35	37	233	220
		-9	1-1/4			22	23	148	143
		-10	1-1/2			15	16	90	90
		-11	2			8	9	55	55
VF-9313-30X-5-P VP-9313-30X-4-P VP-9313-30X-5-P	VB-9313-0-4-P VB-9313-0-5-P	-12	2-1/2					36	35
		-13	3					24	24
		-14	4					13	13
		-15	5	65	65				
No factory assemblies available	VB-7323-0-4-P	-4	1/2			250	250	250	250
		-6	3/4			250	250		
		-8	1			250	250		
		-9	1-1/4			250	250		
		-10	1-1/2						
-11	2								

^a MF-221X3 for hot water and steam applications only.

^b Close-off ratings for mixing or sequencing valves: (SU = "A" port, SD = "B" port). "A" port (SU) ratings equal pressure at port "A" minus pressure at port "B". "B" port (SD) ratings equal pressure at port "B" minus pressure at port "A".

^c SU — Stem Up; SD — Stem Down. Refer to Table 3 and Table 6 for flow pattern, port designations and normal position.

Three Way Valves

Mixing, Diverting; Electric

TABLE 3. Factory Assemblies (VA-X3XX, VC-X3XX and VS-X3XX), select exact Actuator Code (XXX). Any MF-221X3 electric gear train actuator can be assembled to valve bodies with the close-off pressure ratings listed in Table 2 and Table 2A. Select Actuator Type having sufficient close-off for the application. Select actuator, linkage, valve body, and field assemble.

Input Signal	Normal Position	Wiring Figure No. ^a	Voltage	Hz	VA	Aux. Switch	Actuator Part Number	Assembly Series	Actuator Code for Factory Assembly
Two-Position SPST	Stem Up (Spring Return)	Figure No. 1 on page 52	120	60	108	No	EA12	VA-73X3 VA-93X3	321
Two-Position SPST	Stem Down (Spring Return)	Figure No. 1 on page 52	120	60	108	No	EA12	VA-73X3 VA-93X3	322
Two-Position SPDT	None (Non-Spring Return)	Figure No. 1 on page 52	120	60	96	Yes	EA31	VC-73X3 VC-93X3	417
							EA31 w/AV-352		465
Floating SPDT	None (Non-Spring Return)	None	24	60	24	No	MF-22103	VF-73X3	251
							MF-22123		253

^a Refer to the Valve/Actuator Wiring Diagrams in this section.

TABLE 3A. Factory Assemblies (VP-93XX), Multiple Input (refer to table below), select exact Actuator Code (XXX). Any electric gear train actuator can be assembled to valve bodies with the close-off pressure ratings listed in Table 2 and Table 2A. Select Actuator Type having sufficient close-off for the application. Select actuator, linkage, valve body and field assemble. Refer to Wiring Figures on Pages 52 to 57.

Normal Position	INPUT SIGNAL					VoltageVac (Hz)	Aux. Switch	Actuator Part Number	Actuator Code (XXX) for Factory Available Assembly
	4 to 20 mA etc.	Slidewire (Series 90)	SPST	SPDT Snap Acting	SPDT Floating Direct Digital Control				
Stem Down	4	2	8	9	10	120 (60)	Yes	EA42	317
Stem Up			Yes					EA44	318
None			—	Yes	Yes			EA58	423
Non-Spring Return								EA58 w/AV-352	466
							EA76	952	

2. Requires 659A ordered separately, refer to Wiring Figure No. 8.
4. Requires 658A ordered separately, refer to Wiring Figure No. 9.
8. Refer to Wiring Figure No. 2 and Figure No. 3.
9. Refer to Wiring Figure No. 5 and Figure No. 6.
10. Refer to Wiring Figure No. 7 and Figure No. 9.

TABLE 3B. Factory Assemblies VF-93XX for MF-631X3, select Actuator Code (XXX). Refer to Table 3C for optional inputs.

Normal Position	Actuator Part No.	Actuator Code (XXX) for Factory Assembly
None Non-Spring Return	MF-63103	301
	MF-63123	303

TABLE 3C. Input Signal for Actuator MF-63123. Order these control modules separately.

Input Signal	Control Module (order separately)
	MF-63123
4 to 20 mAdc	MFC-420 ^a
6 to 9 Vdc	MFC-8000 ^a

^a Other ranges available by Dip Switch setting on module.

Mixing, Diverting; Electric

TABLE 4. Dimensions in Inches (Millimeters). (Refer to pages 37 through 39 for illustrations.)

Valve Body						Actuator Series (Code)			
						EA12, EA4X	EA31, EA58	EA31, EA58 w/AV-352	EA76
Part Number	Size In.	A	B ^a	C	D ^a	E ^b	E	E	E
VB-7313-0-4-P VB-7314-0-4-P VB-7323-0-4-P	1/2	3 (76)	4-1/4 (108)	1-7/16 (36)	2-7/8 (73)	12-13/16 (325)	13-11/16 (347)	13011/16 (347)	
	3/4	3-5/8 (92)	5-1/2 (140)	1-7/16 (36)	3-3/16 (80)	13-7/8 (351)	14-11/16 (373)	14-11/16 (373)	
	1	4-5/8 (117)	6-3/4 (171)	2-1/8 (53)	3-7/8 (98)	14-1/8 (358)	15 (380)	15 (380)	
	1-1/4		6-7/8 (175)	1-5/8 (42)	3-7/16 (89)	13-5/16 (338)	14-3/16 (338)	14-3/16 (338)	
	1-1/2	5-3/8 (137)	8-5/16 (219)	1-7/8 (48)	3-3/4 (95)	13-7/16 (341)	14-5/16 (363)	14-5/16 (363)	
	2	6-1/8 (156)	9-3/16 (233)	1-7/8 (48)	4-3/16 (105)	12-13/16 (342)	14-3/8 (364)	14-3/8 (364)	
VB-9313-0-4-P	2-1/2	8-1/2 (216)		4-5/8 (117)		16-1/4 (413)	16-1/4 (413)	15-1/4 (387)	
	3	9-1/2 (241)		5 (127)		16-7/16 (417)	16-7/16 (417)	15-7/16 (392)	
VB-9313-0-5-P	2-1/2	8-1/2 (216)		5-3/8 (137)		15-7/8 (403)	15-7/8 (403)	14-7/8 (378)	
	3	9-1/2 (241)		6-3/8 (162)		16-1/4 (413)	16-1/4 (413)	15-1/4 (387)	
	4	11-1/2 (292)		8-1/2 (216)		16-7/8 (429)	16-7/8 (429)	15-7/8 (403)	22 (559)
	5	13 (330)		8-3/4 (222)				18-1/4 (464)	24-3/8 (619)
	6	14 (356)		9-3/4 (248)				19 (483)	25-1/8 (384)
VB-9323-0-5-P	2-1/2	9 (229)		7 (178)		17-1/2 (445)	17-1/2 (445)		
	3	10 (254)		8 (203)		18 (457)	18 (457)		
	4	12 (309)		10 (254)				18-3/4 (476)	
	5	13 (330)		10-1/2 (267)				19-3/8 (492)	
	6	14-1/8 (359)		11-1/8 (283)				20 (508)	

^a Use B and D dimensions for VB-7314 valve body.

^b Subtract 3/4 in. (19 mm) on VA assemblies.

Mixing, Diverting; Electric

TABLE 5. Dimensions in Inches (Millimeters). (Refer to the pages 37 through 39 for illustrations.)

Valve Body						Actuator Series (Code)	
Part Number	Size In.	A	B ^b	C	D ^a	MF-221X3 ^a	MF-631X3
						E	E
VB-7313-0-4-P VB-7314-0-4-P VB-7323-0-4-P	1/2	3 (76)	4-1/4 (108)	1-7/16 (36)	2-7/8 (73)	4-1/4 (107)	7 (177)
	3/4	3-5/8 (92)	5-1/2 (140)	1-7/16 (36)	3-3/16 (80)	5-1/4 (133)	8 (203)
	1	4-5/8 (117)	6-3/4 (171)	2-1/8 (53)	3-7/8 (98)	5-1/2 (140)	8-5/16 (210)
	1-1/4		6-7/8 (175)	1-5/8 (42)	3-7/16 (89)	4-3/4 (120)	7-1/2 (190)
	1-1/2	5-3/8 (137)	8-5/16 (219)	1-7/8 (48)	3-3/4 (95)	4-7/8 (124)	7-5/8 (193)
	2	6-1/8 (156)	9-3/16 (233)	1-7/8 (48)	4-3/16 (105)	4-7/8 (124)	7-11/16 (194)
VB-9313-0-4-P	2-1/2	8-1/2 (216)		4-5/8 (117)			12-5/8 (321)
	3	9-1/2 (241)		5 (127)			14 (356)
VB-9313-0-5-P	2-1/2	8-1/2 (216)		5-3/8 (137)			13-7/16 (341)
	3	9-1/2 (241)		6-3/8 (162)			13-13/16 (351)
	4	11-1/2 (292)		8-1/2 (216)			14-7/16 (367)

^a MF-221X3 for hot water and steam applications only.

^b Use B and D dimensions for VB-7314 valve body.

Mixing, Diverting; Electric

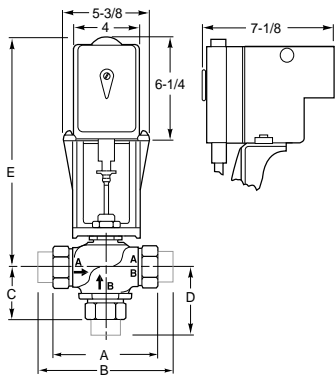

EA12
EA4X
with
VB-7313-0-4-P
VB-7314-0-4-P
VB-7323-0-4-P

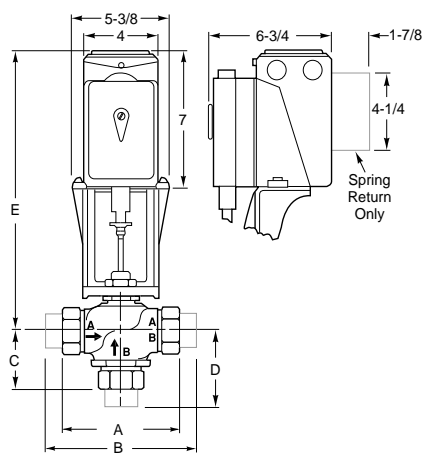

EA31
EA58
with
VB-7313-0-4-P
VB-7314-0-4-P
VB-7323-0-4-P

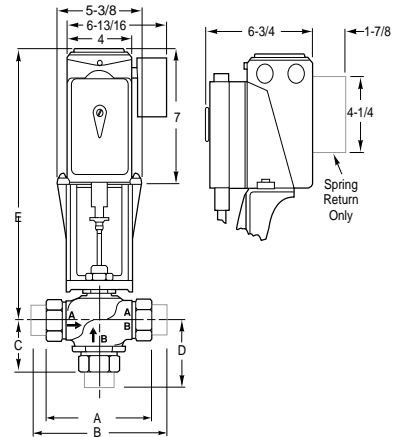

EA58 with
VB-7313-0-4-P
VB-7314-0-4-P
VB-7323-0-4-P
and Electronic Drive
when 658A is installed

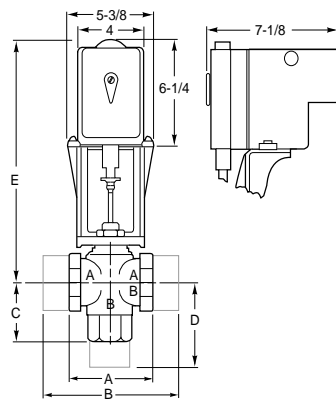

EA12, EA4X
with
VB-9313-0-4-P
VB-9314-0-4-P
VB-9323-0-4-P

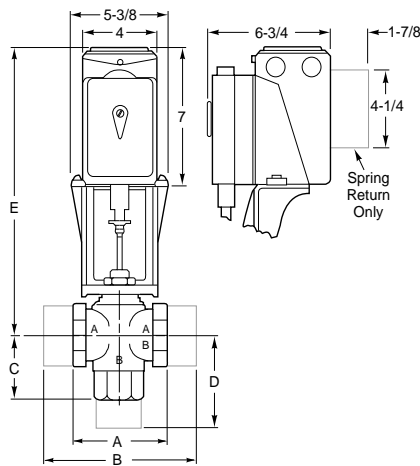

EA31, EA58
with
VB-9313-0-4-P
VB-9314-0-4-P
VB-9323-0-4-P

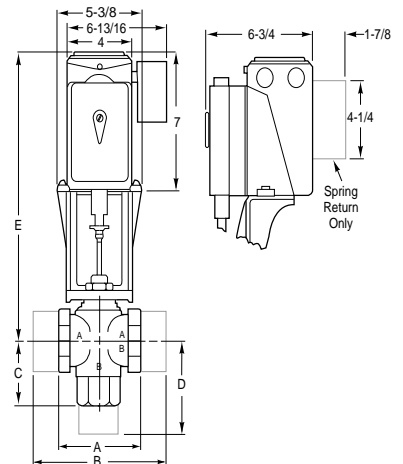

EA58 with
VB-9313-0-4-P
VB-9314-0-4-P
VB-9323-0-4-P
with 658A installed

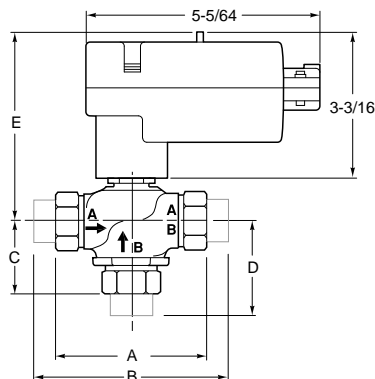

MF-221X3 with
VB-7313-0-4-P
VB-7314-0-4-P
VB-7323-0-4-P

Three Way
Valves

Mixing, Diverting; Electric

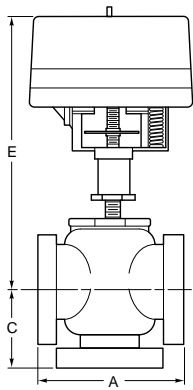

MF-631X3 with
VB-9313-000-5-P
No Factory Assemblies

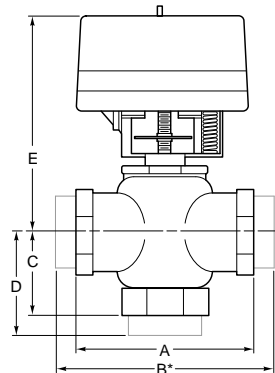
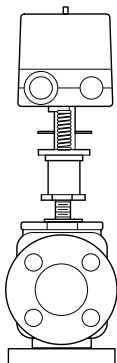

* For VB-9314

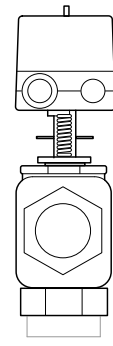

MF-631X3 with
VB-9313-000-4-P
VB-9314-000-4-P
VB-9323-000-4-P

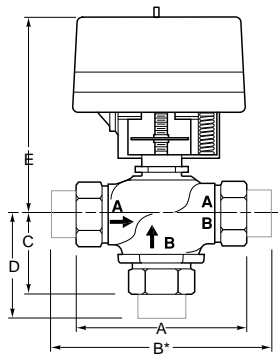

* For VB-7314

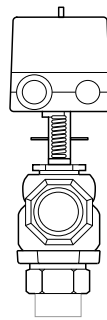

MF-631X3 with
VB-7313-000-4-P
VB-7314-000-4-P
VB-7323-000-4-P

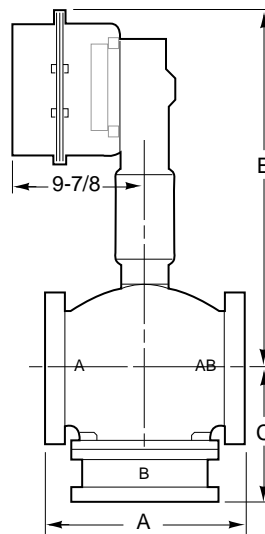

EA76 with
VB-9313-0-5-P

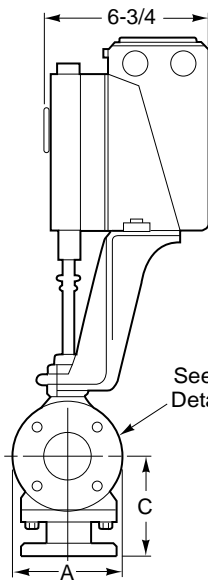
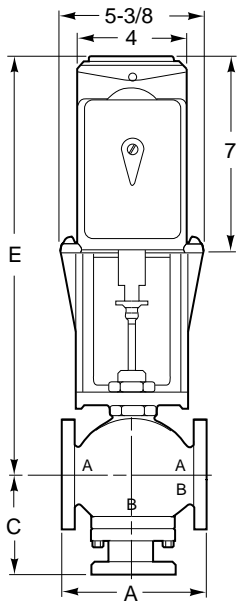
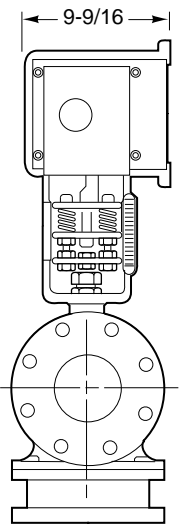

EA31, EA58
with
VB-9313-0-5-P
VB-9323-0-5-P

See Flange
Detail Table

Three Way
Valves

Mixing, Diverting; Electric

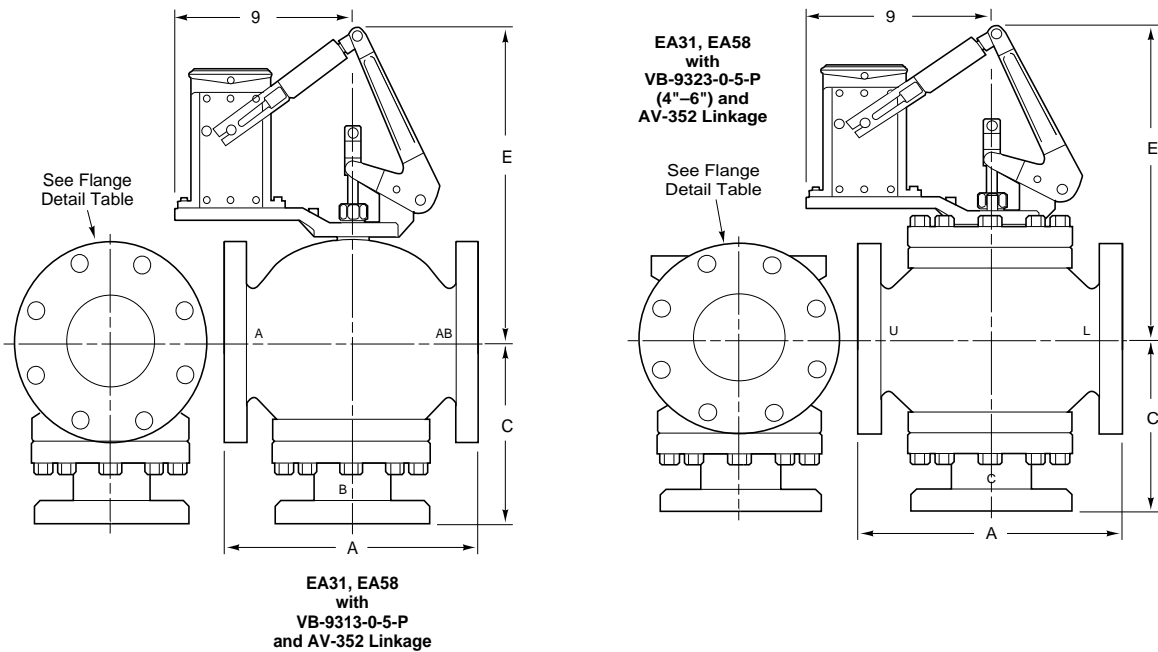
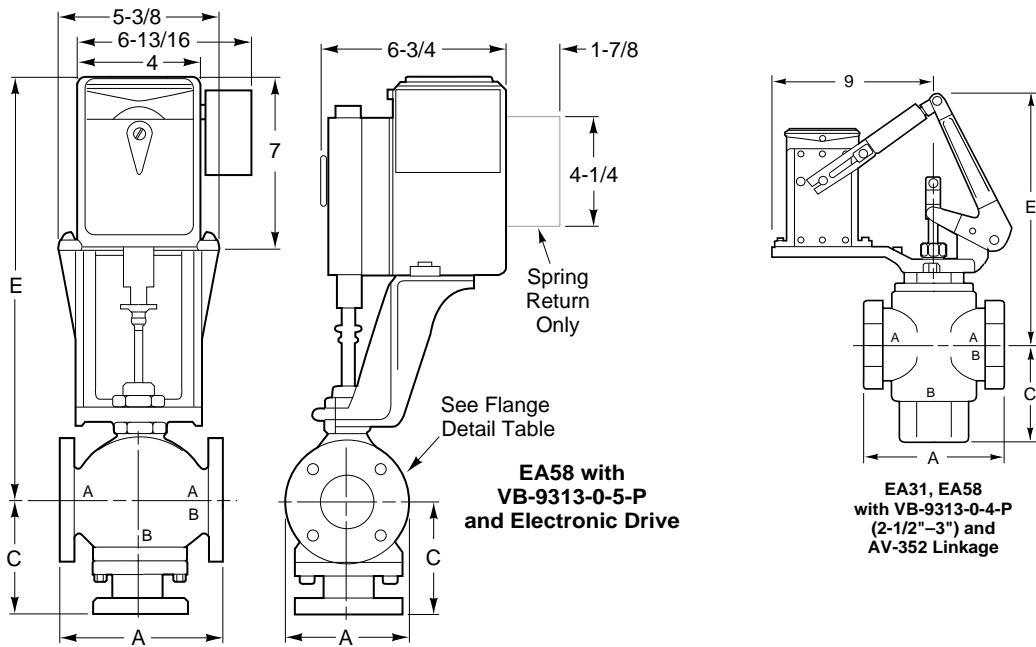

Three Way Valves

Mixing, Diverting; Electric

American Standard 125 lb. Cast Iron Pipe Flanges.

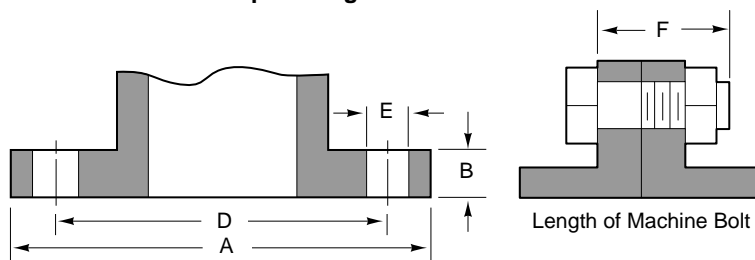

Flange Detail Dimensions in Inches (Metric conversion 25.4 mm = 1 in.).

Nominal Pipe Size	Flanges		Drilling		Bolting		Length of Machine Bolts F
	Flange Diameter A	Flange Thickness B	Diameter of Bolt Circle D	Diameter of Bolt Holes E	Number of Bolts	Diameter of Bolts	
2-1/2	7	11/16	5-1/2	3/4	4	5/8	2-1/2
3	7-1/2	3/4	6	3/4	4	5/8	2-1/2
4	9	15/16	7-1/2	3/4	8	5/8	3
5	10	15/16	8-1/2	7/8	8	3/4	3
6	11	1	9-1/2	7/8	8	3/4	3-1/4

TABLE 6. Flow Pattern.

Body Part Number	Flow Type	Stem Up (SU)		Stem Down (SD)	
		Flow	Closed Port	Flow	Closed Port
VB-7313-0-4-P VB-7314-0-4-P VB-9313-0-5-P	Mixing	B to AB	A	A to AB	B
VB-7323-0-4-P VB-9323-0-5-P	Diverting	C to L	U	C to U	L

TABLE 7. Restrictions on Maximum Ambient Temperature for Valve Actuators.

TEMPERATURES °F (°C)								
Actuator Code		317, 321	251 ^a	253 ^a	30X	417, 423	465, 466	952
Actuator Series		EA12, EA4X	MF-22103	MF-22123	MF-631X3	EA31, EA58	EA31, EA58 w/AV-352	EA76
Maximum Ambient		136 (57)	140		140 (60)	136 (57)	136 (57)	130 (54)
Max. Allowable Fluid		260 (127)	220	200	260 (126)	260 (127)	260 (127)	260 (127)
VB-9313-0-5-P	Maximum Fluid	300 (149)	281		300 (149)	300 (149)	300 (149)	300 (149)
VB-9323-0-5-P	Max. Allowable Ambient	100 (38)	115		100 (38)	100 (38)	100 (38)	100 (38)
VB-7313-0-4-P VB-7314-0-4-P VB-7323-0-4-P VB-9313-0-4-P	Maximum Fluid	281 (138)	281		281 (138)	281 (138)	281 (138)	—
VB-9314-0-4-P VB-9323-0-4-P	Max. Allowable Ambient	125 (52)	115		125 (52)	125 (52)	125 (52)	—

^a MF-221X3 for hot water and steam applications only.

Static Pressure Versus Temperature Ratings

Maximum Temperature and Pressure Ratings for Valve Bodies

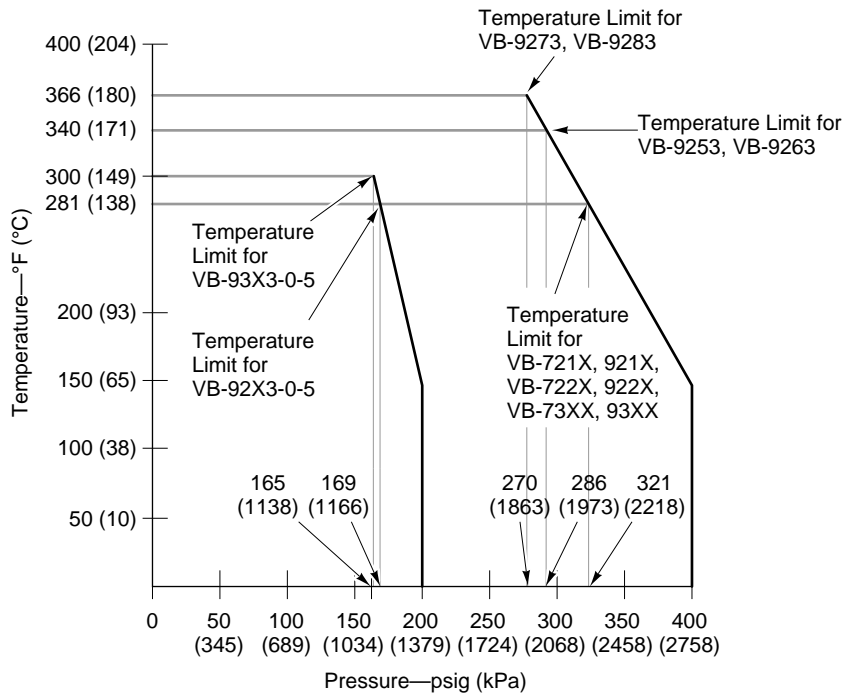

Ratings conform with published values and disclaimer.

- Cast Bronze: Screwed & Union End Fittings (VB-9XXX-0-4-P, VB-7211-0-3-P).
- Bronze:
 - ASTM Standards.
 - Pressure to ANSI B16.15 Class 250 with 400 psi up to 150°F decreasing to 346 psi at 281°F.
- Cast Iron:
 - Flanged End Fittings (VB-9XXX-0-5-P).
 - Materials: ASTM A126 Class B.
 - ANSI B16.1 Class 125 with 200 psi up to 150°F decreasing to 169 psi at 281°F.

Caution: Do not use valves beyond rating of piping system and components. Consult ANSI B16.22 for ratings of solder joint pressure fittings.

Flow Curves and Rangeability

Flow Curves

Flow curves shown below are representative of all sizes.

All valve plugs have lower gain when nearly closed to enhance control at low demand. Mixing and diverting valves are nominally linear. Separate curves shown for "A" or "B" ports are not directly additive. Total flow with both ports contributing is rated C_v .

Two-way valves with brass trim are nominally equal percentage in the composition disc types and normally used for water and low pressure steam.

Two-way valves with stainless trim are nominally linear in the TFE and metal-to-metal disc types, and normally used for higher temperature water and steam.

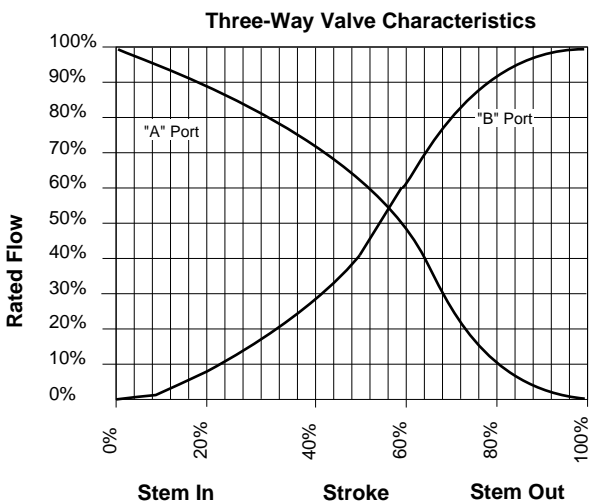
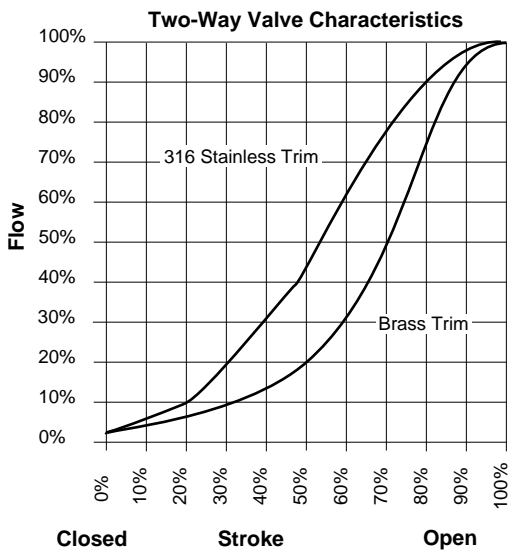

Rangeability

Rangeability is defined as the ratio of rated to minimum controllable flow.

For mixing and diverting valves, control begins as soon as plug displacement allows flow. Thus, Three-way valve rangeability normally exceeds 500:1 which is the reciprocal of 0.2% nominal leakage.

For Two-way valves, modulation occurs when plug displacement allows flow through the area between the plug and the port. The rangeability value is achieved by accurately machining the plug and port diameters for appropriate clearance. The following are normal values, with 25% tolerances.

TABLE 8. Two-way Valve Rangeability.

Nominal Size		Port Code (P)	Nominal Ratio
Standard	Metric		
1/2"	15 mm	1	5:1
		2	15:1
		3	25:1
		4	40:1
3/4"	20 mm	5	50:1
		6	60:1
1"	25 mm	7	60:1
		8	75:1
1-1/4"	32 mm	9	75:1
1-1/2"	40 mm	10	75:1
2"	50 mm	11	75:1
2-1/2"	65 mm	12	75:1
3"	80 mm	13	75:1
4"	—	14	75:1
5"	—	15	75:1
6"	—	16	75:1

Guidelines

Valve Packing Life

Valve packings are designed to provide many years of useful life before they must be replaced.

The actual life, under the standard specified conditions, will vary — depending on the frequency of valve cycle and the condition of the fluid controlled. The more frequently the valve is cycled and the more contaminated the fluid is with dirt and harsh chemicals, the shorter the life of the packing

Water System Guidelines

All heating and cooling systems are susceptible to valve and system problems caused by improper water treatment and system storage problems. These guidelines are provided to help avoid valve and water system problems from improperly treated water or storage procedures in cooling and hot water systems in cooling and hot water systems, and to obtain maximum life from Barber-Colman valves. While all cooling and heating systems are susceptible to problems, closed chilled water systems, including those containing brine or glycol, are especially prone to system and valve problems. The best way to avoid problems is to follow the advice of a professional water treatment and control specialist.

Leak Prevention. Durability of valve stems and packing is dependent on maintaining non-damaging water conditions. Inadequate water treatment or filtration, not in accordance with the recommendations of a qualified water treatment specialist or the ASHRAE handbook, can result in corrosion, scaling, or abrasive particle formation. Scale and corrosion products can migrate from pipe walls to control valves, resulting in stem and packing scratches, and can adversely affect packing life and other parts of the hydronic system. This condition can be avoided by the use of proper cleaning, treatment chemicals, and storage procedures.

To maintain non-damaging conditions, the system should be cleaned prior to start-up. Filtration equipment should be used where needed, and regularly scheduled program of water condition monitoring and/or treatment should be followed.

Control valve operation should be stable and not hunt at any time. Excessive stroking of the valve stem due to improper system setup can result in premature wear.

Cleaning. New systems usually contain dirt, solder flux, and weld and pipe scale. Thorough flushing with a 1% to 2% solution of trisodium phosphate and rinsing is recommended.

Wet Storage. If the system is stored wet, it should be completely filled with properly treated water and isolated to avoid slow leaks which can contribute to serious corrosion problems.

Dry Storage. If drained, the system should be air dried, sealed, and treated with a desiccant to prevent atmospheric corrosion of pipes — a major source of pipe scale. Pipe scale is dried rust which will slough off the pipe

walls as abrasive particles and migrate through the system.

Strainers and Filters. Many closed systems have slow leaks or seepage, resulting in water loss without particulate removal. Consequently, particulate solids often build up in those systems, resulting in deposits. In open systems like cooling towers, particulate solid build-up is not as common because continuous blowdown is used to remove solids from the system.

Side stream filtration is often needed in closed systems because there is no regular blowdown to remove pipe scale, sand, grit, and other abrasive or sticky particulate matter. Abrasive particles must not be allowed to circulate through the system.

To determine whether a filtration system is required, perform a visual inspection of the water. Flush a line with turbulence to assure that a representative water sample is collected and observe the turbidity. Let the water settle for five minutes and inspect for particulate that has dropped out.

If chip scale and particulate are found in circulation, install some type of filtration device such as a “Y” strainer, a cartridge filter, and automatic backwashing side stream sand filter, or a chemical pot feeder packed with cheesecloth that can be replaced periodically. Backwashing sand filters (sized at 1% to 3% of system circulation rate) are often a good choice because they are simple, inexpensive, and effective.

Lines carrying water to and from the filtration system should be sized for high flow rates to make sure the particulate matter is carried into the filtration system.

Filtration is often necessary when chemical treatment is started in a system which has not previously been chemically treated. The treatment often dislodges old deposits which then migrate to heat exchangers and valves unless removed by filtration.

Before installing a sophisticated filtration system, make sure strainer baskets are emptied regularly. Also make sure the baskets have not been permanently removed — a common practice when they fill up quickly and too much work is required to keep them clean.

Before installing filters or strainers in systems containing glycol, consult the glycol vendor for proper type.

Chemical Water Treatment. If the make-up water hardness is greater than 300 ppm as calcium carbonate, the water should be softened or a treatment should be used that contains a polymeric dispersant material which forms a soft sludge instead of allowing the formation of hard scales.

Make-up water iron should be less than 1.0 ppm. Manganese should be less than 0.5 ppm (0.05 ppm if the system has significant leakage). If not, an iron/manganese removal system or a new water source should be used.

Water treatment control addresses four problem areas:

Guidelines

corrosion, scale, deposition, and bacteria. For control, a nitrite or molybdate based program is typically used in conjunction with testing and monitoring.

The corrosion control program most commonly used is 600 to 1220 ppm sodium nitrite or 100 to 300 ppm molybdate, at a pH of 9.5 to 10.5. Include a copper corrosion inhibitor such as Tolytriazol (TTA) or Benzotriazole (BZT) since uncontrolled copper corrosion can lead to corrosion of steel.

Note – *The addition of glycol, especially automotive antifreeze, does not assure corrosion protection. Refer to the manufacturer's literature for specific requirements, including concentrations and materials of construction.*

Control of bacteria is important because bacteria can break down the nitrites. The level of bacteria should be kept at less than 10,000 CFUs (colony forming units) per ml of water. Follow your supplier's instructions for bacterial control.

Operate your chemical treatment program within the guidelines set by your water treatment supplier. Monitor results monthly, switching to weekly if problem resolution is necessary.

Control Loop Operation. Valves should not be oversized. Set the control system operating parameters so that hunting does not occur, even at light load conditions such as fall, spring, and morning operation. Valves which cycle often or continuously require a preventive maintenance program to replace worn parts.

Valve Sizing Information for Water

GENERAL INFORMATION REQUIRED

1. Fluid controlled:
 - Chilled water, hot water, or steam.
2. Temperature limitations:
 - Fluid, maximum, and minimum.
 - Ambient for actuator.
3. Pressure:
 - Static.
 - Close-off — Fully closed.
 - Differential — Pressure drop across the valve in the fully open position.
4. End fitting:
 - Union end.
 - Globe screwed.
 - Flared.
 - Flanged.
 - Flangeless.
5. For return to a known position (i.e., normally open or normally closed): Specify 200 or 300 Series spring return actuator.
6. Dimensional data.
7. C_v (flow coefficient) requirement is calculated from flow rate and differential pressure. Refer to formulas and tables.

For additional sizing and selection background information, refer to:

- CA-28 Control Valve Sizing, F-13755.
- CA-27 Three-Way Valves, F-12348.
- CA-15 Control of High Temperature Water Systems, F-7638.
- CA-13 Fundamentals of Hot Water Pump Installation, F-7767.

RECOMMENDED PRESSURE DROPS FOR WATER

Refer to specific valve data in this catalog for maximum allowable pressure drops and close-off ratings.

A. Two-Position Valves

Two-position valves are normally selected “line size” to keep pressure drop at a minimum. If desirable to reduce valve below line size, then 10% of “available pressure” normally used to select valve.

B. Proportional Two-Way Valves

Usually selected to take a pressure drop equal to at least 50% of the “available pressure” (i.e., the pump pressure differential available between supply and return mains with design flow at the valve location). As “available pressure” is often difficult to calculate, the normal procedure is to select the valve using a pressure drop at least equal to the drop in the coil or other load being controlled (except where small booster pumps are used), but never less than 5 psi (34 kPa).

When design temperature drop is less than 60°F (33°C) for

conventional heating systems, higher pressure drops across the valve are needed for good control results. Refer to the following table.

Conventional Heating Systems

Design Temp. Drop °F (°C)	Recom. Pressure Drop ^a (% of Available Pressure)	Multiplier on Load Drop
60 (33) or more	50%	1 x load drop
40 (22)	66%	2 x load drop
20 (11)	75%	3 x load drop

^a Recommended minimum pressure drop — 5 psi (34 kPa).

Secondary Circuits with Small Booster Pumps

50% of Available Pressure Difference (Equal to drop through load, or 50% of booster pump head)

C. Proportional Three-Way Valves

Recommended Pressure Drop — Bypass Application: 50% of “available pressure”, or equal to pressure drop through the load at full flow.

Three-way valves in the return used to control heat output by throttling water flow to the load (bypass applications) are controlling output in the same manner as throttling two-way valves, and must be selected using the same high pressure drops if good control results are to be obtained.

Recommended Pressure Drop — Constant Flow Applications: 20% of “available pressure”, or equal to 1/4 of the pressure drop through the load at full flow.

Three-way valves used with individual pumps to control heat output by varying water temperature to the load (constant flow applications) are controlling output by mixing two water sources at different temperatures, and do not require high pressure drops for good control results.

In most cases the required C_v falls between two valve sizes. If the pressure drop of the smaller is acceptable for the application, select the smaller valve.

CAVITATION LIMITATIONS ON VALVE PRESSURE DROP

A valve selected with too high a pressure drop can cause erosion of discs and/or wire drawing of the seat. In addition, cavitation can cause noise, damage to the valve trim (and possibly the body) and choke the flow through the valve.

Do not exceed the maximum differential pressure (pressure drop) for the valve selected.

The following formula can be used on higher temperature water systems, where cavitation could be a problem, to estimate the maximum allowable pressure drop across the valve:

$$P_m = 0.5 (P_1 - P_v)$$

P_m = Maximum allowable pressure drop

P_1 = Absolute inlet pressure (psia)

P_v = Absolute vapor pressure (refer to Vapor Pressure of Water Table or Steam Table)

Valve Sizing Information for Water

Note: Add 14.7 psi to gauge supply pressure to obtain absolute pressure value.

For example, if a valve is controlling 200°F water at an inlet pressure of 18 psig, the maximum pressure drop allowable would be:

$$P_m = 0.5 [(18 + 14.7) - 11.53] = 10.6 \text{ psi}$$

(Vapor pressure of 200°F water is 11.53 psi)

If the pressure drop for this valve is less than 10.6 psi, cavitation should not be a problem.

Systems where cavitation is shown to be a problem can sometimes be redesigned to provide lower inlet velocities. Valves having harder seat materials should be furnished if inlet velocities cannot be lowered.

C_v (FLOW COEFFICIENT) DETERMINATION

The Water Valve Sizing Table or Slide Rule (refer to the following page) is based on the following formula:

$$C_v = \frac{\text{GPM}}{\sqrt{\Delta P}} \text{ or } C_v = \text{GPM} \sqrt{\frac{\text{Specific Gravity}}{\Delta P}}$$

Where: C_v = Coefficient of flow

C_v is defined as the flow in GPM with ΔP = 1 psi

GPM = U.S. gallons per minute (60°F, 15.6°C)

ΔP = Differential pressure in psi (pressure drop)

Other forms of this formula are:

$$\Delta P = \left(\frac{\text{GPM}}{C_v} \right)^2$$

and

$$\text{GPM} = C_v \sqrt{\Delta P}$$

These formulas can be used to calculate one of the three quantities if the other two are known.

Flow coefficients (C_v's) for valve bodies are given on valve specification pages of this catalog.

Metric (SI) Units

Kvs is defined as the flow in m³/h with ΔP = 100 kPa (1.0 Bar) with the valve completely open.

Flow is calculated using the following formula:

$$m^3/h = kvs \sqrt{\Delta P}$$

Where:

ΔP = Differential pressure (pressure drop) in Bar
(1 Bar = 100 kPa)

m³/h = Cubic metres/hour (15.6 °C)

Pressure drop is calculated using the following form of the above formula:

$$\Delta P = \left(\frac{m^3/h}{kvs} \right)^2$$

These formulas can be used to calculate one of the three quantities if the other two are known.

TABLE 1. Vapor Pressure of Water Table.

Water Temperature °F	Vapor Pressure psig	Water Temperature °F	Vapor Pressure psig
40	0.12	140	2.89
50	0.18	150	3.72
60	0.26	160	4.74
70	0.36	170	5.99
80	0.51	180	7.51
90	0.70	190	9.34
100	0.95	200	11.53
110	1.28	210	14.12
120	1.69	220	17.19
130	2.22	230	20.78

Valve Sizing Information for Water

WATER VALVE SIZING TABLES

WATER CAPACITY IN GALLONS PER MINUTE										
Cv ^a	Differential Pressure (psi) ΔP									
	2	3	4	5	10	15	20	25	30	35
0.4	0.57	0.69	0.80	0.89	1.26	1.55	1.79	2.0	2.2	2.4
0.95	1.3	1.7	1.9	2.12	3.0	3.7	4.3	4.8	5.2	5.6
1.3	1.8	2.2	2.6	2.9	4.1	5.0	5.8	6.5	7.1	7.7
1.4	2.0	2.4	2.8	3.1	4.4	5.4	6.3	7.0	7.7	8.3
1.7	2.4	2.9	3.4	3.8	5.4	6.6	7.6	8.5	9.3	10.1
2	2.8	3.5	4.0	4.5	6.3	7.8	8.9	10	11	12
2.2	3.1	3.8	4.4	4.9	7.0	8.5	9.8	11	12	13
2.4	3.4	4.2	4.8	5.4	7.6	9.3	10.7	12	13	14
2.5	3.5	4.3	5.0	5.6	7.9	10	11	13	14	15
3.3	4.7	5.7	6.6	7.4	10.4	13	15	17	18	20
3.6	5.1	6.2	7.2	8.1	11.4	14	16	18	20	21
3.8	5.4	6.6	7.6	8.5	12.0	15	17	19	21	22
4	5.7	6.9	8.0	8.9	12.7	15	18	20	22	24
5	7.1	8.7	10	11	15	19	22	25	27	30
5.5	7.9	9.5	11	12	17	21	25	28	30	33
6	8.5	10.4	12	13	19	23	27	30	33	36
6.2	8.8	10.7	12	14	20	24	28	31	34	37
6.8	9.6	11.8	14	15	22	26	30	34	37	40
7.4	10.5	12.8	15	17	23	29	33	37	41	44
7.5	10.6	13.0	15	17	24	29	34	38	41	44
8	11.3	13.9	16	18	25	31	36	40	44	47
8.2	11.6	14.2	16	18	26	32	37	41	45	49
8.5	12.0	14.7	17	19	27	33	38	43	47	50
9	12.7	15.6	18	20	28	35	40	45	49	53
10.5	15	18	21	23	33	41	47	53	58	62
11	16	19	22	25	35	43	49	55	60	65
12	17	21	24	27	38	46	54	60	66	71
15	21	26	30	34	47	58	67	75	82	89
16	23	28	32	36	51	62	72	80	88	95
17.4	25	30.1	35	39	55	67	78	87	95	104
25	35	43	50	56	79	97	112	125	137	148
30	42	52	60	67	95	116	134	150	164	177
33	47	57	66	74	104	128	148	165	181	195
35.8	51	62	72	80	113	139	160	179	196	212
40	57	69	80	89	126	155	179	200	219	237
42	59	73	84	94	133	163	188	210	230	248

Note: This table is based on water at 60°F (16°C).

^a Cv values correspond to electric valve offering.

WATER CAPACITY IN GALLONS PER MINUTE										
Cv ^a	Differential Pressure (psi) ΔP									
	2	3	4	5	10	15	20	25	30	35
45	64	78	90	101	142					
55	78	95	110	123	174	213	246	275	301	325
56	79	97	112	125	177	217	250	280	307	331
65	92	113	130	145	206	251	291	325	356	385
67	95	116	134	150	212	259	300	335	367	396
68	96	118	136	152	215	263	250	340	372	402
70	99	121	140	157	221	271	313	350	383	414
74	105	128	148	165	234	287	331	370	405	438
75	106	130	150	168	237	290	335	375	411	444
85	120	147	170	190	269	329	380	425	466	503
91	129	158	182	203	288	352	407	455	498	538
100	141	173	200	224	316					
101	143	175	202	226	319	391	452	505	553	598
109	154	189	218	244	345	422	487	575	597	645
115	163	199								
145	205	251	290	324	459	562	648	725	794	858
160	226	277	320	358	506	620	716	800	876	947
170	240	294	340							
179	253	310	358	400	566	693	801	895	980	1059
195	276	338	390	436	617	755	872	975	1068	1154
200	283	346	400	447						
235	332	407	470	525	743	910	1051	1175	1287	1390
250	354	433	500	559	791	968	1118	1250	1369	1479
275	389	476	550							
290	410	502	580	648	917	1123	1297	1450	1588	1716
300	424	520	600	671	949	1162	1342	1500	1643	1775
350	495	606	700	783	1107	1356	1565	1750	1917	2071
390	552	676	780	872	1233	1510	1744	1950	2136	2307
425	601	736	850							
440	622	762	880	984	1391	1704	1968	2200	2410	2603
640	905	1108	1280							
680	962	1178								
1125	1591	1949	2250							
1150	1626	1992	2300							
1750	2475	3031	3500							
1850	2616	3204	3700							
2600	3677	4503	5200							
2650	3748	4590								
3400	4808	5889								
4500	6364									

WATER VALVE SIZING SLIDE RULE

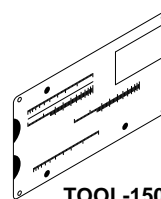

TOOL-150

General Information

Valve Sizing Information for Steam

RECOMMENDED PRESSURE DROPS FOR STEAM

Refer to specific valve data in this catalog for maximum allowable drops and close-off ratings.

A. Two Position Zone Valves and Direct Radiator Valves

Use a minimum of 10% of inlet pressure (psig).

B. Proportional Control Valves

Low pressure (15 psig or less): ΔP of 80% of gauge inlet pressure.

When Cv required is between two valve sizes and closer to the smaller valve size, re-size for Cv using 42% of the absolute inlet pressure as pressure drop. Use the valve that is larger than the calculated Cv.

For steam pressures greater than 15 psig: 42% of the absolute inlet pressure.

When Cv required is between two valve sizes, select the larger size.

Note: Do not size steam valves on higher system pressures using a pressure drop greater than 42% of the absolute inlet pressure.

Cv (FLOW COEFFICIENT) DETERMINATION

The Steam Capacity Tables or Slide Rule (refer to this and the following two pages) is based on the following formula:

$$C_v = \frac{QK}{3\sqrt{\Delta P \times P_2}}$$

Where: Cv = Coefficient of flow

Q = Lbs per hour of steam

ΔP = Differential pressure in psi (pressure drop)

P_2 = Outlet pressure in psia (absolute)
psig + 14.7 = psia (absolute)

K = 1 + (0.0007 x °F super-heat)

Note: K normally is 1 (K = 1 for saturated steam).

Other forms of the formula are:

$$Q = \frac{3C_v\sqrt{\Delta P \times P_2}}{K}$$

Note: K normally is 1.

$$\Delta P = \left(\frac{QK}{3C_v}\right)^2 \times \frac{1}{P_2}$$

Note: K normally is 1.

$$P_2 = \left(\frac{QK}{3C_v}\right)^2 \times \frac{1}{\Delta P}$$

Note: K normally is 1 (K = 1 for saturated steam).

These formulas can be used to calculate one of the quantities if the others are known.

Flow coefficients (Cv's) for specific valve bodies are given on specification pages of this catalog.

STEAM VALVE SIZING SLIDE RULE

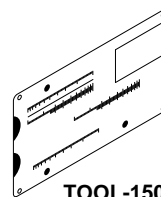

TOOL-150

General Information

STEAM CAPACITY IN POUNDS PER HOUR

Note: Table is based on saturated steam.

Inlet Pressure psig ΔP	2#		5#		10#		15#		20#		25#		40#		50#		75#		100#	
	Cv	0.2 ^a	1.6	0.5 ^a	4	1 ^a	8	1.5 ^a	12	2 ^a	14	2.5 ^a	16	4 ^a	23	5 ^a	27	7.5 ^a	37	10 ^a
0.4	2.2	5.9	3.7	9.5	5.9	13.9	7.8	17.5	9.7	20.4	11.6	23.4	17.1	32.4	20.7	38.3	29.8	53	38.8	68
0.95	5.2	14	8.8	22.6	13.9	32.9	18.5	41.5	23	48.5	27.5	55.5	40.6	77	49.2	90.9	70.8	126	92.2	161
0.99	5.4	14.6	9.2	23.5	14.5	34.3	19.3	43.3	24	50.6	28.6	57.8	42.3	80.2	51.3	94.8	73.7	131	96.1	168
1.1	6	16.2	10.2	26.2	16.1	38.1	21.5	48.1	26.7	56.2	31.8	64.3	47	89.1	57	105.3	81.9	146	106.8	187
1.3	7.1	19.2	12.1	31	19	45.1	25.4	56.8	31.5	66.4	37.6	75.9	55.5	24.3	67.4	124.4	96.8	172	126.2	221
1.8	9.8	27	18.7	43	26.3	62.4	35.1	78.7	43.7	91.9	52.1	105.2	76.9	145.8	93.3	172.3	134.1	238	174.7	306
2.2	12	32.4	20.4	52	32	76	43	96	53	112	63.6	128.5	94	178	114	210.6	164	291	213.6	373
2.5	13.6	37	23	59	37	87	49	109	61	128	72	146	107	203	130	239	186	331	342	424
3.3	18	49	31	79	48	114	64	144	80	169	95	193	141	267	171	316	246	437	320	560
3.6	19.6	53	34	86	53	125	70	157	87	184	104	210	154	292	187	345	268	477	349	611
3.8	20.7	56	35	90	56	132	74	166	92	194	110	222	162	308	197	364	283	503	369	645
4.0	22	59	37	95	58	139	78	175	47	204	116	234	171	324	207	383	298	530	388	679
5	27	74	47	119	73	173	98	219	121	255	145	292	214	405	259	479	372	662	485	848
5.5	30	81	51	131	80	191	107	240	1334	281	159	321	235	446	285	526	410	728	534	934
6	33	89	56	143	88	208	117	262	146	306	174	351	256	486	311	574	447	795	582	1018
6.2	34	91	58	147	91	215	121	271	150	317	179	362	265	502	321	593	462	821	602	1052
7.4	40	109	69	176	108	257	144	324	180	378	214	432	316	599	384	708	551	980	718	1256
7.5	41	111	70	178	110	260	146	328	182	383	217	438	320	608	389	718	559	994	728	1273
8.2	45	121	76	195	120	284	160	359	199	419	237	479	350	664	425	785	611	1086	796	1392
8.5	46	125	79	202	124	295	166	372	206	434	246	497	363	689	441	814	633	1126	825	1443
9	49	133	84	214	131	312	176	393	218	460	260	526	385	729	466	861	670	1192	874	1528
10.5	57	155	98	250	153	364	205	459	255	536	304	613	449	851	544	1005	782	1391	1019	1782
11	60	162	102	262	161	381	215	481	267	562	318	643	470	891	570	1053	819	1457	1068	1867
15	82	221	139	357	219	520	293	656	304	766	434	876	641	1215	777	1436	1117	1987	1456	2546
16	87	236	149	380	234	555	312	700	388	817	463	935	684	1296	829	1531	1192	2120	1553	2716
17.4	95	257	162	414	254	603	340	761	422	889	503	1016	743	1409	902	1665	1296	2305	1689	2954
25	136	369	232	594	365	867	488	1093	607	1277	723	1460	1068	2025	1296	2393	1862	3312	2427	4244
35.8	195	528	333	851	523	1241	699	1565	867	1828	1036	2091	1529	2900	1856	3427	2667	4742	3475	6077
40	218	590	372	951	584	1387	780	1749	970	2043	1157	2337	1709	3240	2073	3829	2980	5299	3883	6790
45	245	664	418	1070	657	1560	878	1967	1092	2298	1302	2629	1923	3645	2332	4307	3352	5961	4368	7639

^a For two-position control.

STEAM CAPACITY IN POUNDS PER HOUR

Note: Table is based on saturated steam.

Inlet Pressure psig ΔP	2#		5#		10#		15#		20#		25#		40#		50#		75#		100#		
	Cv	0.2 ^a	1.6	0.5 ^a	4	1 ^a	8	1.5 ^a	12	2 ^a	14	2.5 ^a	16	4 ^a	23	5 ^a	27	7.5 ^a	37	10 ^a	48
56	305	826	521	1331	818	1942	1093	2448	1359	2860	1620	3271	2392	4536	2903	5360	4171	7418	5436	9506	
65	354	958	604	1545	949	2254	1268	2842	1577	3320	1881	3797	2777	5265	3369	6221	4842	8611	6310	11034	
70	381	1032	651	1664	1022	2427	1366	3061	1698	3575	2025	4089	2991	5670	3628	6670	5214	9273	6795	11882	
75	409	1106	697	1783	1095	2601	1463	3279	1820	3830	2170	4381	3204	6075	3887	7179	5587	9935	7280	12731	
85	463	1253	790	2021	1241	2947	1658	3716	2062	4341	2459	4966	3631	6885	4406	8136	6332	11260	8251	14429	
100	545	1475	930	2377	1460	3468	1951	4372	2426	5107	2893	5842	4272	8101	5183	9571	7449	13247	9707	16975	
115	627	1696	1069	2734	1680	3988	2244	5028	2790	5873	3327	6718	4913	9316	5961	11007	8566	15234	11163	19521	
145	790	2138	1348	3447	2118	5028	2829	6340	3518	7405	4195	8471	6195	11746	7516	13878	10801	19208	14075	24613	
170	926	2507	1580	4042	2483	5895	3317	7433	4124	8682	4918	9931	7263	13771	8811	16271	12663	22519	16502	28857	
200	1090	2949	1859	4755	2921	6935	3902	8744	4852	10214	5786	11684	8544	16201	10366	19143	14898	26494	19414	33950	
235	1281	3465	2184	5587	3432	8149	4585	10275	5701	12002	6799	13729	10040	19036	12180	22493	17505	31130	22812	39891	
275	1499	4055	2556	6538	4016	9536	5366	12024	6672	14044	7956	16065	11749	22277	14254	26321	20484	36429	26695	46681	
350	1907	5161	3253	8321	5112	12136	6829	15303	8491	17875	10126	20447	14953	28352	18141	33500	26071	46264	33975	59412	
425	2316	6267	3950	10104	6207	14737	8292	18582	10311	21705	12296	24828	18157	34427	22028	40678	31658	56300	41256	72143	
440	2398	6488	4090	10461	6426	15257	8585	19238	10675	22471	12730	25704	18798	35642	22806	42114	32775	58287	42712	74689	
640	3488	9437	5949	15215	9347	22192	12487	27982	15527	32685	18516	37388	27342	51844	33172	61257	47672	84781	62126	108639	
680	3706	10027	6321	16166	9931	23579	13268	29731	16498	34728	19673	39725	29051	55084	35245	65085	50652	90080	66009	115429	
1125	6131	16589	10457	26746	16430	39010	21950	49187	27294	57454	32547	65722	48063	91131	58310	107678	83799	149029	109206	190967	
1150	6267	16958	10689	27340	16796	39877	22438	50280	27900	58731	33271	67182	49131	93156	59606	110071	85661	152341	111633	195210	
1750	9537	25805	16267	41604	25558	60682	34145	76513	42457	89373	50629	102234	74764	141760	90705	167499	130354	231823	169876	297059	
1850	10082	27280	17196	43982	27019	64150	36096	80885	44883	94481	53522	108076	79036	149860	95888	177070	137803	245070	179583	314034	
2600	14169	38339	24167	61812	37972	90157	50730	113677	63079	132783	75220	151890	111078	210614	134762	248855	193669	344422	252388	441345	
2650	14442	39076	24632	63001	38703	91890	51706	115863	64292	135337	76667	154811	113214	214665	137353	253641	197394	351046	257241	449832	
3400	18529	50136	31604	80831	49656	117897	66339	148654	82488	173640	98365	198625	145256	275419	176227	325426	253260	450398	330045	577143	
4500	24524	66356	41828		65722		87802		109175		130189										
5400	29429	79628	50194		78866		105362														
7000	38148		65066		102234																
10000	54498		92952																		

^a For two-position control.

Valve/Actuator Wiring Diagrams

Wiring Figure No. 1

SPST controller required.

Valve Assembly	Normal Position	Powered Position
VA-721X-30X VA-921X-30X	Open	Closed
VA-721X-31X VA-921X-31X	Closed	Open
VA-731X-30X VA-931X-30X	Flow "B" to "AB"	Flow "A" to "AB"
VA-7323-30X VA-9323-30X	Flow "B" to "AB"	Flow "B" to "A"

Two-Position, Two-Wire Electric, Spring Return

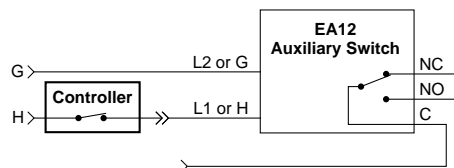

Wiring Figure No. 2

SPST controller required.

Valve Assembly	Normal Position	Powered Position
VP-721X-3XX VP-921X-3XX	Closed	Open
VP-2224-15X		
VP-731X-3XX VP-931X-3XX	Flow "A" to "AB"	Flow "B" to "AB"
VP-7323-3XX-4 VP-9323-3XX-4	Flow "B" to "A"	Flow "B" to "AB"
VP-9323-3XX-5	Flow "C" to "U"	Flow "C" to "L"

Two-Position, Two-Wire Electric, Spring Return

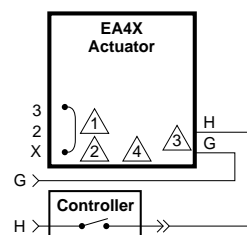

- 1 Install jumper between terminals 3 and X.
- 2 Remove green wire between X terminal and Case Ground Screw to unground actuator.
- 3 Terminals G and H are marked L1 and L2 on line voltage actuators.
- 4 Terminals 1, 5 and 6 are used for built-in auxiliary switches.

Note: Switch control circuit is 0.5 amp at approximately 24 Vac on either low or line voltage actuators.

Wiring Figure No. 3

SPST controller required.

Valve Assembly	Normal Position	Powered Position
VP-721X-3XX VP-921X-3XX	Open	Closed
VP-2224-15X		
VP-731X-3XX VP-931X-3XX	Flow "B" to "AB"	Flow "A" to "AB"
VP-7323-3XX-4	Flow "B" to "AB"	Flow "B" to "A"
VP-9323-3XX-5	Flow "C" to "L"	Flow "C" to "U"

Two-Position, Two-Wire Electric, Spring Return

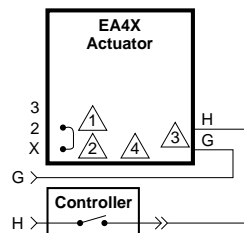

- 1 Install jumper between terminals 2 and X.
- 2 Remove green wire between X terminal and Case Ground Screw to unground actuator.
- 3 Terminals G and H are marked L1 and L2 on line voltage actuators.
- 4 Terminals 1, 5 and 6 are used for built-in auxiliary switches.

Note: Switch control circuit is 0.5 amp at approximately 24 Vac on either low or line voltage actuators.

Valve/Actuator Wiring Diagrams

Wiring Figure No. 4

SPDT controller required.

(As Factory Linked)

Valve Assembly	"C" to "B" on Actuator	"C" to "R" on Actuator
VC-721X-4XX VC-921X-4XX	Closed	Open
VC-731X-4XX VC-931X-4XX	Flow "A" to "AB"	Flow "B" to "AB"
VC-7323-4XX-4	Flow "B" to "A"	Flow "B" to "AB"
VC-9323-4XX-5	Flow "C" to "U"	Flow "C" to "L"

Two-Position, Three-Wire Electric

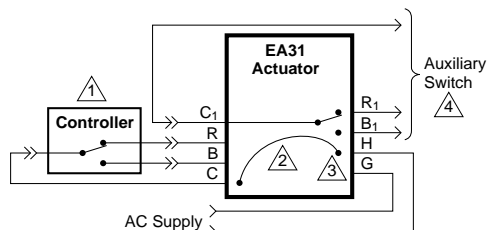

- ① One SPDT switch can control only one actuator.
- ② Internal jumper.
- ③ Terminals G and H are marked L1 and L2 on line voltage actuators.
- ④ C₁, made to R₁, with stem up.

Wiring Figure No. 5

SPDT controller required.

(As Factory Linked)

Valve Assembly	"X" to "2" on Actuator	"X" to "3" on Actuator
All	Stem Down	Stem Up
VP-2224	Closed	Open
VP-7213, 7214, 9213		
VP-7313, 9313, 9314	Flow "A" to "AB"	Flow "B" to "AB"
VP-7323-XXX-4	Flow "B" to "A"	Flow "B" to "AB"
VP-9323-XXX-5	Flow "C" to "U"	Flow "C" to "L"

Two-Position, Three-Wire Electric

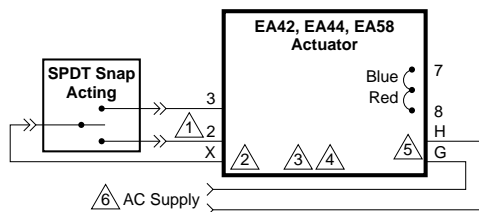

- ① 2—Rotates CW or Closes Valve (Lowers Stem).
3—Rotates CCW or Opens Valve (Raises Stem).
- ② Remove green wire between X terminal and Case Ground Screw to unground actuator.
- ③ Terminals 1, 5, and 6 are used for built-in auxiliary switches.
- ④ For spring return stem down (Normally Closed) use MP-X6X actuator. For spring return stem up (Normally Open) use MP-X7X actuator.
- ⑤ Terminals G and H are marked L1 and L2 on line voltage actuators.
- ⑥ Switch control circuit is 0.5 amp at approximately 24 Vac on either low or line voltage actuators.

Wiring Figure No. 6

SPDT controller required.

Valve Assembly	"L ₁ " to "2" on Actuator	"L ₁ " to "3" on Actuator
VP-9213, 9214	Closed	Open
VP-9313, 9314	Flow "A" to "AB"	Flow "B" to "AB"

Two-Position, Three-Wire Electric

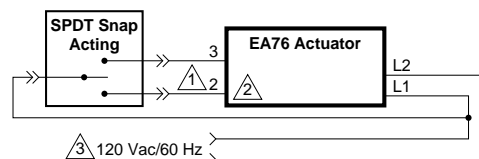

- ① 2—Rotates CW or Closes Valve (Lowers Stem).
3—Rotates CCW or Opens Valve (Raises Stem).
- ② Terminals 1, 5, and 6 are used for built-in auxiliary switches.
- ③ Switch control circuit is 1.8 amp at 120 Vac.

Valve/Actuator Wiring Diagrams

Wiring Figure No. 7

(As Factory Linked)

Valve Assembly	"X" to "2" on Actuator	"X" to "3" on Actuator
All	Stem Down	Stem Up
VP-2224	Closed	Open
VP-7213, 7214, 9213		
VP-7313, 931X	Flow "A" to "AB"	Flow "B" to "AB"
VP-7323-XXX-4 VP-9323-XXX-4	Flow "B" to "A"	Flow "B" to "AB"
VP-9323-XXX-5	Flow "C" to "U"	Flow "C" to "L"

Reversible Floating, Direct Digital Control

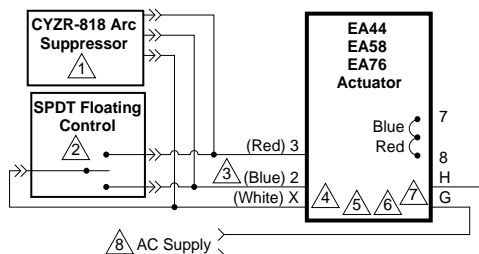

- 1 Arc Suppressor purchased separately. Install under cover of actuator.
- 2 SPDT Neutral Off Switch may be used on manual positioning applications.
- 3 2—Rotates CW or Closes Valve (Lowers Stem).
3—Rotates CCW or Opens Valve (Raises Stem).
- 4 Remove green wire between X terminal and Case Ground Screw to unground actuator.
- 5 Terminals 1, 5, and 6 are used for built-in auxiliary switches.
- 6 For spring return stem down (Normally Closed) use MP-X6X actuator. For spring return stem up (Normally Open) use MP-X7X actuator.
- 7 Terminals G and H are marked L1 and L2 on line voltage actuators.
- 8 Switch control circuit is 0.5 amp at approximately 24 Vac on either low or line voltage actuators.

Valve/Actuator Wiring Diagrams

Wiring Figure No. 8

Slidewire Input

Valve Assembly	CCW Rotation of Actuator	CW Rotation of Actuator
All	Stem Down	Stem Up
VP-2224	Open	Closed
VP-721X, 9213		
VP-731X, 9313	Flow "B" to "AB"	Flow "A" to "AB"
VP-7323-XXX-4 VP-9323-XXX-4	Flow "B" to "AB"	Flow "B" to "A"
VP-9323-XXX-5	Flow "C" to "L"	Flow "C" to "U"

For spring return stem down (normally closed) use MP-X6X actuator.
For spring return stem up (normally open) use MP-X7X actuator.

Slidewire Input Wattage Requirements

Max. Ω Slidewire	Watts Required per Actuator	Max. Number of Actuators per Slidewire
100 to 135	1.5	3
136 to 1000	3	1

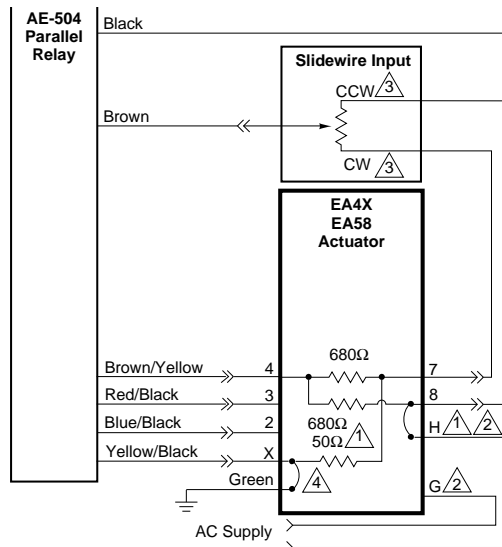

- ① 50 Ω resistor & jumper to H present on 24V actuators only.
- ② Terminals G1 and H are marked L1 and L2 on line voltage actuators.
- ③ Direction actuator will drive.
- ④ Green wire between terminal X and case ground screw.

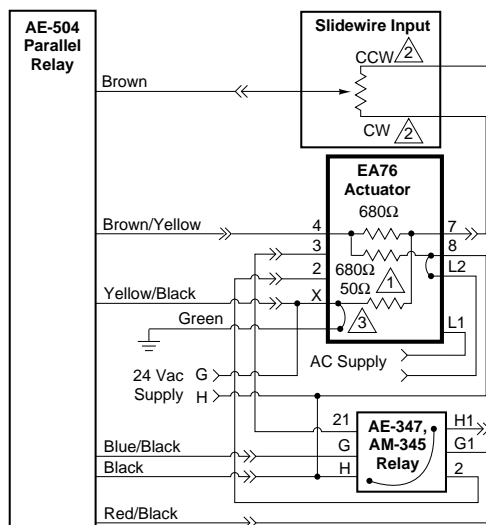

- ① Resistors are 5 watt.
- ② Direction actuator will drive.
- ③ Green wire between terminal X and case ground screw.

General Information

Valve/Actuator Wiring Diagrams

Wiring Figure No. 9

Current Input 4 to 20 mA, etc.

Valve Assembly	CCW Rotation of Actuator	CW Rotation of Actuator
All	Stem Up	Stem Down
VP-721X, 9213	Open	Closed
VP-731X, 9313	Flow "B" to "AB"	Flow "A" to "AB"
VP-7323-XXX-4 VP-9323-XXX-4	Flow "B" to "AB"	Flow "B" to "A"
VP-9323-XXX-5	Flow "C" to "L"	Flow "C" to "U"

For spring return stem down (normally closed) use MP-X6X actuator.

For spring return stem up (normally open) use MP-X7X actuator.

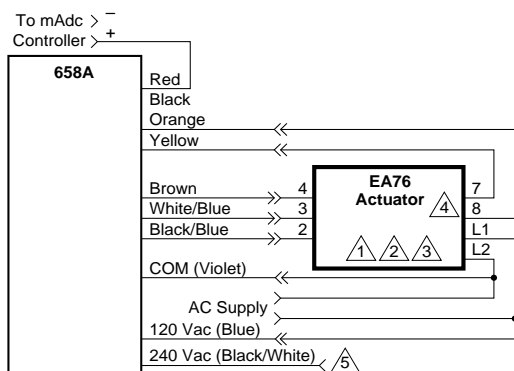

- 1 Terminals 1, 5, and 6 are used for built-in auxiliary switches.
- 2 Actuator rotates counter clockwise with increase in input signal.
- 3 References to the direction of the actuator shaft rotation are determined by looking at the actuator output shaft.
- 4 Actuator must not have a built-in transformer, or if a built-in transformer is present, remove red and blue leads from terminals 7 and 8 and tape off.
- 5 240 Vac supply. Wire to L1 on 240 Vac Actuators.

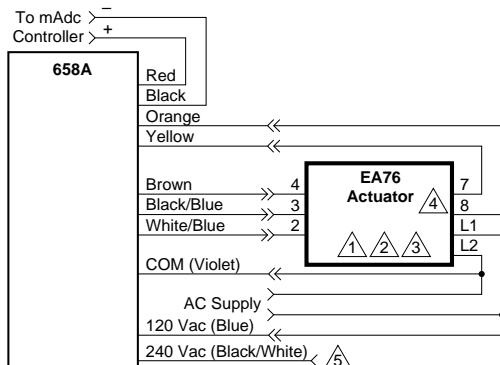

- 1 Terminals 1, 5, and 6 are used for built-in auxiliary switches.
- 2 Actuator rotates clockwise with increase in input signal.
- 3 References to the direction of the actuator shaft rotation are determined by looking at the actuator output shaft.
- 4 Actuator must not have a built-in transformer, or if a built-in transformer is present, remove red and blue leads from terminals 7 and 8 and tape off.
- 5 240 Vac supply. Wire to L1 on 240 Vac Actuators.

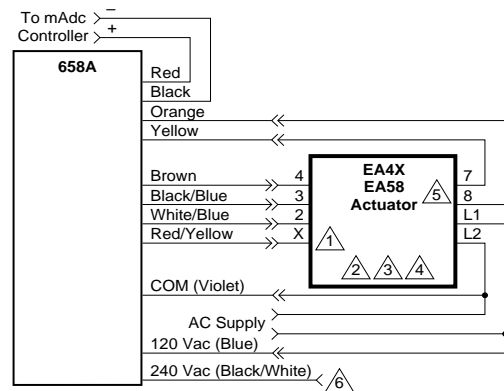

- 1 Green wire between X terminal and Case Ground Screw grounds actuator. 658A is optically isolated, so the actuator can be grounded.
- 2 Terminals 1, 5, and 6 are used for built-in auxiliary switches.
- 3 Actuator rotates clockwise with increase in input signal.
- 4 References to the direction of the actuator shaft rotation are determined by looking at the actuator output shaft.
- 5 Actuator must not have a built-in transformer, or if a built-in transformer is present, remove red and blue leads from terminals 7 and 8 and tape off.
- 6 Wire to L1 on 240 Vac Actuator.

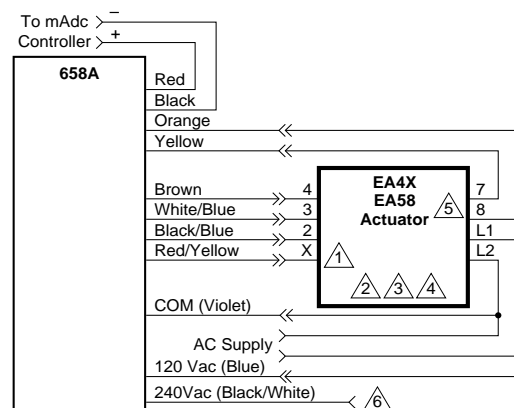

- 1 Green wire between X terminal and Case Ground Screw grounds actuator. 658A is optically isolated, so the actuator can be grounded.
- 2 Terminals 1, 5, and 6 are used for built-in auxiliary switches.
- 3 Actuator rotates counter clockwise with increase in input signal.
- 4 References to the direction of the actuator shaft rotation are determined by looking at the actuator output shaft.
- 5 Actuator must not have a built-in transformer, or if a built-in transformer is present, remove red and blue leads from terminals 7 and 8 and tape off.
- 6 240 Vac supply. Wire to L1 on 240 Vac Actuators.

Valve/Actuator Wiring Diagrams

Wiring Figure No. 10

Controllers, 4 to 20 mADC

Valve Assembly	Increasing Vdc Input Signal	Normal Position Decreasing Vdc
VS-9211	Closed	Open
VS-9212		
VS-721X		
VS-7221	Open	Closed
VS-7222		
VS-722X		
VS-731X	Flow "A" to "AB"	Flow "B" to "AB"
VS-7323-XXX-4	Flow "B" to "A"	Flow "B" to "AB"

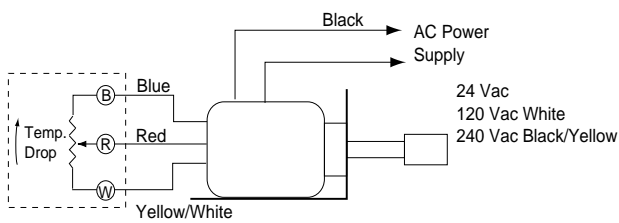

EA81-17006 Actuators with 135 Ω Slidewire Input
Actuator Extends on Temperature Drop

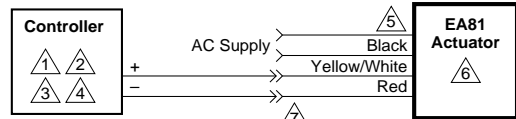

- 1 Controller output signal: 4 to 20 mADC.
- 2 Controller supplied by others.
- 3 Controller has setpoint and throttling range (proportional band) adjustments. Controller may also incorporate I (integral) and D (differential) functions.
- 4 Controller output can be either:

Direct Acting (DA): Increase in measured media causes the controller output (4 to 20 mADC) signal to increase.	Reverse Acting (RA): Increase in measured media causes the controller output (4 to 20 mADC) signal to decrease.
--	---
- 5

Vac	Color
24	Black/Blue
120	White
240	White/Black
- 6 **Sequence of Operation:** Increases in the controller signal cause the MPR-561X Actuator shaft to extend. On power loss to the Actuator, the shaft retracts.

Valve Body Cross Reference

Valve Body

To select the required valve linkage proceed with the following steps:

1. Match the part number below with the part number on the valve.
2. Use the part number in parenthesis and the appropriate actuator part number to select the required valve linkage from the valve linkage selection guide on the following pages.

CYBC-372 (VB-202)	VA-101 (VB-314)	VC-8044 (VB-804)	VP-1112 (VB-111)	VU-1312 (VB-131)
CYBC-374 (VB-202)	VA-102 (VB-324)	VC-8174 (VB-817)	VP-1212 (VB-121)	VU-2024 (VB-202)
CYBC-375 (VB-202)	VA-1100 (VB-111)	VC-9213 (VB-9213)	VP-1312 (VB-131)	VU-2124 (VB-212)
CYBC-406 (VB-202)	VA-1102 (VB-111)	VC-9214 (VB-9214)	VP-1512 (VB-151)	VU-2452 (OYBB-233)
CYBC-408 (VB-202)	VA-1112 (VB-111)	VC-9223 (VB-9223)	VP-2024 (VB-202)	VU-3044 (VB-804)
CYBC-409 (VB-202)	VA-1210 (VB-121)	VC-9253 (VB-9253)	VP-2025 (VB-202)	VU-3142 (VB-314)
DYBB-121 (VB-804)	VA-1212 (VB-121)	VC-9273 (VB-9273)	VP-2026 (VB-202)	VU-3242 (VB-324)
DYBB-123 (VB-804)	VA-1300 (VB-131)	VC-9313 (VB-9313)	VP-2124 (VB-212)	VU-3342 (VB-334)
DYBB-140 (VB-804)	VA-1302 (VB-131)	VC-9314 (VB-9314)	VP-2452 (OYBB-233)	VU-3542 (VB-354)
DYBB-142 (VB-804)	VA-1312 (VB-131)	VC-9323 (VB-9323)	VP-2624 (VB-262)	VU-8044 (VB-804)
DYBB-208 (VB-131)	VA-1512 (VB-151)	VK-1114 (VB-111)	VP-3044 (VB-804)	VU-8174 (VB-817)
DYBB-209 (VB-131)	VA-2001 (VB-202)	VK-1115 (VB-111)	VP-3045 (VB-804)	VU-9213 (VB-9213)
DYBB-268 (VB-131)	VA-2021 (VB-202)	VK-1214 (VB-121)	VP-3046 (VB-804)	VU-9223 (VB-9223)
DYBB-275 (VB-252)	VA-2101 (VB-212)	VK-1215 (VB-121)	VP-3142 (VB-314)	VU-9253 (VB-9253)
DYBB-282 (VB-131)	VA-2121 (VB-212)	VK-1314 (VB-131)	VP-3242 (VB-324)	VU-9263 (VB-9263)
DYBB-293 (VB-334)	VA-2402 (OYBB-223)	VK-1315 (VB-151)	VP-3342 (VB-334)	VU-9273 (VB-9273)
DYBB-294 (VB-324)	VA-3041 (VB-804)	VK-1514 (VB-151)	VP-3542 (VB-354)	VU-9283 (VB-9283)
DYBB-295 (VB-324)	VA-3140 (VB-314)	VK-1515 (VB-151)	VP-8044 (VB-804)	VU-9313 (VB-9313)
DYBB-296 (VB-334)	VA-3142 (VB-314)	VK-2025 (VB-202)	VP-8045 (VB-804)	YBA-530 (VB-111)
DYBB-297 (VB-324)	VA-3240 (VB-324)	VK-2027 (VB-202)	VP-8174 (VB-817)	YBA-531 (VB-111)
DYBB-298 (VB-324)	VA-3242 (VB-324)	VK-2125 (VB-212)	VP-9213 (VB-9213)	YBA-532 (VB-111)
DYBB-299 (VB-324)	VA-3500 (VB-354)	VK-2127 (VB-212)	VP-9214 (VB-9214)	YBA-533 (VB-111)
DYBB-300 (VB-324)	VA-3502 (VB-354)	VK-2454 (OYBB-233)	VP-9223 (VB-9223)	YBA-541 (VB-111)
DYBB-301 (VB-324)	VA-3542 (VB-354)	VK-2455 (OYBB-233)	VP-9253 (VB-9253)	YBA-542 (VB-111)
DYBB-302 (VB-314)	VA-8041 (VB-804)	VK-2525 (VB-252)	VP-9263 (VB-9263)	YBA-543 (VB-111)
DYBB-303 (VB-314)	VA-8171 (VB-817)	VK-2527 (VB-252)	VP-9273 (VB-9273)	YBA-544 (VB-111)
DYBB-304 (VB-354)	VA-9211 (VB-9211)	VK-3045 (VB-804)	VP-9283 (VB-9283)	YBA-545 (VB-111)
DYBB-305 (VB-354)	VA-9212 (VB-9212)	VK-3047 (VB-804)	VP-9313 (VB-9313)	YBA-546 (VB-111)
DYBB-306 (VB-131)	VA-9213 (VB-9213)	VK-3144 (VB-314)	VP-9323 (VB-9323)	YBA-565 (VB-111)
DYBB-307 (VB-131)	VA-9214 (VB-9214)	VK-3145 (VB-314)	VS-2023 (VB-202)	YBA-566 (VB-111)
DYBB-308 (VB-131)	VA-9221 (VB-9221)	VK-3244 (VB-324)	VS-2523 (VB-252)	YBA-567 (VB-111)
DYBB-309 (VB-131)	VA-9222 (VB-9222)	VK-3245 (VB-324)	VS-8043 (VB-804)	YBA-568 (VB-111)
DYBB-310 (VB-131)	VA-9223 (VB-9223)	VK-3342 (VB-344)	VS-8173 (VB-817)	YBA-569 (VB-111)
DYBB-311 (VB-131)	VA-9224 (VB-9224)	VK-3344 (VB-334)	VS-9211 (VB-9211)	YBA-570 (VB-111)
DYBB-313 (VB-354)	VA-9253 (VB-9253)	VK-3345 (VB-334)	VS-9212 (VB-9212)	YBA-571 (VB-121)
DYBB-314 (VB-354)	VA-9263 (VB-9263)	VK-3544 (VB-354)	VS-9213 (VB-9213)	YBA-572 (VB-121)
DYBB-315 (VB-354)	VA-9273 (VB-9273)	VK-8045 (VB-804)	VS-9214 (VB-9214)	YBA-573 (VB-121)
DYBB-316 (VB-314)	VA-9283 (VB-9283)	VK-8047 (VB-804)	VS-9221 (VB-9221)	YBA-574 (VB-121)
DYBB-317 (VB-314)	VA-9312 (VB-9312)	VK-8177 (VB-817)	VS-9222 (VB-9222)	YBA-575 (VB-121)
DYBB-318 (VB-314)	VA-9313 (VB-9313)	VK-9211 (VB-9211)	VS-9223 (VB-9223)	YBA-576 (VB-121)
OYBB-109 (VB-202)	VA-9314 (VB-9314)	VK-9212 (VB-9212)	VS-9224 (VB-9224)	YBA-585 (VB-121)
OYBB-110 (VB-202)	VA-9332 (VB-9332)	VK-9213 (VB-9213)	VS-9253 (VB-9253)	YBA-586 (VB-121)
OYBB-113 (VB-212)	VC-20 (VB-202)	VK-9214 (VB-9214)	VS-9263 (VB-9263)	YBA-588 (VB-121)
OYBB-114 (VB-212)	VC-21 (VB-212)	VK-9221 (VB-9221)	VS-9273 (VB-9273)	YBA-589 (VB-121)
OYBB-115 (VB-202)	VC-100 (VB-804)	VK-9222 (VB-9222)	VS-9283 (VB-9283)	YBA-590 (VB-121)
OYBB-116 (VB-202)	VC-2004 (VB-202)	VK-9223 (VB-9223)	VS-9312 (VB-9312)	YBA-591 (VB-121)
OYBB-119 (VB-212)	VC-2005 (VB-202)	VK-9224 (VB-9224)	VS-9313 (VB-9313)	YBA-595 (VB-131)
OYBB-120 (VB-212)	VC-2006 (VB-202)	VK-9253 (VB-9253)	VS-9314 (VB-9314)	YBA-596 (VB-131)
OYBB-242 (OYBB-233)	VC-2007 (VB-202)	VK-9263 (VB-9263)	VS-9323 (VB-9323)	YBA-597 (VB-131)
OYBB-257 (OYBB-233)	VC-2024 (VB-202)	VK-9273 (VB-9273)	VS-9332 (VB-9332)	YBA-602 (VB-131)
OYBB-258 (OYBB-233)	VC-2104 (VB-212)	VK-9283 (VB-9283)	VU-82 (VB-202)	YBA-603 (VB-131)
OYBB-259 (OYBB-233)	VC-2106 (VB-212)	VK-9312 (VB-9312)	VU-84 (VB-111)	YBA-604 (VB-131)
OYBB-276 (VB-260)	VC-2107 (VB-212)	VK-9313 (VB-9313)	VU-85 (OYBB-233)	YBA-605 (VB-131)
OYBB-309 (VB-262)	VC-2124 (VB-212)	VK-9314 (VB-9314)	VU-86 (VB-121)	YBA-606 (VB-131)
VA-11 (VB-111)	VC-2304 (VB-260)	VK-9323 (VB-9323)	VU-101 (VB-314)	YBA-607 (VB-131)
VA-12 (VB-121)	VC-2307 (VB-260)	VK-9332 (VB-9332)	VU-102 (VB-324)	YBA-608 (VB-131)
VA-20 (VB-202)	VC-2604 (VB-260)	VP-82 (VB-202)	VU-103 (VB-334)	YBA-609 (VB-131)
VA-100 (VB-804)	VC-3044 (VB-804)	VP-83 (VB-212)	VU-1112 (VB-111)	YBA-610 (VB-131)
	VC-3047 (VB-804)	VP-100 (VB-804)	VU-1212 (VB-121)	

Linkages

Valve Linkage Selection Guide

Valve Body Part Number	Valve Sizes	ACTUATOR PART NUMBER										
		Electric/Electronic										
		MA-3X8-XXX MA-416-XXX MA-4X8-XXX MA-4X9-XXX	MA-521X-XXX	MC-31X MC-32X MC-41X MC-41X1	All MC-3XX, 4XX, 4XXX Except Those in Preceding Column	MF-631X3	MP-32X, 33X, 36X, 37X, 42XX, 43XX, 46XX, 47XX, 21XX (180° Models Only)	MP-34X, 35X, 38X, 44XX, 45XX, 48XX (180° Models Only)	MP-503 MP-513 MU-503 MU-504 MU-506	MF-5X1X, MP-521X-XXX, MP-54XX, MP-55XX, MPR-561X, MPR-571X, MPR-581X	MU-4610X MU-4710X	MM/MMR-400 MM/MMR-500
VB-111-0-X-X	1/2 to 1-1/4 in.	—	AV-600	—	—	—	—	—	AV-308	AV-600 ^a	—	—
VB-121-0-X-X	1/2 in. O.D.	—	AV-600	—	—	—	—	—	AV-308	AV-600 ^a	—	—
VB-131-X-X-X	5/8 or 7/8 in. O.D.	—	AV-600	—	—	—	—	—	AV-308	AV-600 ^a	—	—
VB-151-0-1-X	1/2 to 1-1/4 in.	—	AV-600	—	—	—	—	—	AV-308	AV-600 ^a	—	—
VB-202-0-1-X	1/2 to 2 in.	AV-300 & AV-21	—	AV-300 & AV-21	AV-300 & AV-30	—	AV-300 & AV-21	AV-300 & AV-30 ^b	—	—	AV-300 & AV-21	—
VB-202-0-2-X	2-1/2 to 4 in.	AV-300 & AV-29	—	AV-300 & AV-29	AV-300 & AV-30	—	AV-300 & AV-29	AV-300 & AV-30	—	—	AV-300 & AV-29	—
VB-202-0-2-X	5 & 6 in.	—	—	—	AV-352	—	—	AV-352	—	—	—	—
VB-212-0-1-X	1/2 to 2 in.	AV-300 & AV-21	—	AV-300 & AV-21	AV-300 & AV-30	—	AV-300 & AV-21	AV-300 & AV-30 ^b	—	—	AV-300 & AV-21	—
VB-222-0-1-1,2,3,5,7	1/2 & 3/4 in.	AV-347	—	AV-347	AV-347-10	—	AV-347	AV-347-10	—	—	AV-347	—
VB-222-0-X-6,8,10	3/4, 1 & 1-1/2 in.	AV-347-20	—	AV-347-20	AV-347-30	—	AV-347-20	AV-347-30	—	—	AV-347-20	—
VB-252-0-1-X	1/2 to 2 in.	—	—	—	—	—	—	—	—	—	—	—
VB-252-0-2-X	2-1/2 to 4 in.	—	—	—	—	—	—	—	—	—	—	—
VB-260-0-1-X	1/2 & 3/4 in.	—	—	—	AV-333	—	—	—	—	—	—	—
VB-260-0-1-X	1 to 1-1/2 in.	—	—	—	AV-300 & AV-30	—	—	—	—	—	—	—
VB-262-0-1-X	1/2 to 1-1/2 in.	—	—	—	AV-300 & AV-30	—	—	AV-300 & AV-30	—	—	—	—
VB-314-0-1-X	1/2 to 1 in.	—	AV-600	—	—	—	—	—	AV-308	AV-600 ^a	—	—
VB-324-0-5-4	1/2 in. O.D.	—	AV-600	—	—	—	—	—	AV-308	AV-600 ^a	—	—
VB-334-0-5-4	1/2 in. O.D.	—	AV-600	—	—	—	—	—	AV-308	AV-600 ^a	—	—
VB-354-0-5-X	5/8 or 7/8 in. O.D.	—	AV-600	—	—	—	—	—	AV-308	AV-600 ^a	—	—
VB-804-0-1-X	1/2 to 2 in.	AV-300 & AV-21	—	AV-300 & AV-21	AV-300 & AV-30	—	AV-300 & AV-21	AV-300 & AV-30 ^b	—	—	AV-300 & AV-21	—
VB-804-0-2-X	2-1/2 to 4 in.	AV-300 & AV-29	—	AV-300 & AV-29	AV-300 & AV-30	—	AV-300 & AV-29	AV-300 & AV-30	—	—	AV-300 & AV-29	—
VB-804-0-2-X	5 & 6 in.	—	—	—	AV-352	—	—	AV-352	—	—	—	—
VB-807-0-1-X	1/2 to 2 in.	AV-300 & AV-21	—	AV-300 & AV-21	AV-300 & AV-30	—	AV-300 & AV-21	AV-300 & AV-30	—	—	AV-300 & AV-21	—
VB-817-0-X-X	1/2 to 3 in.	AV-300 & AV-29	—	AV-300 & AV-29	AV-300 & AV-30	—	AV-300 & AV-29	AV-300 & AV-30	—	—	AV-300 & AV-29	—
VB-817-0-X-X	4 to 6 in.	—	—	—	AV-352	—	AV-352	AV-352	—	—	—	—
VB-7211-0-4-X	1/2 to 1-1/4 in.	—	AV-600-0-0-1	—	—	AV-671 ^c	—	—	AV-308-0-0-1	AV-600-0-0-1 ^a	—	—
VB-7212-0-4-X	5/8 in. O.D.	—	AV-600-0-0-1	—	—	—	—	—	AV-308-0-0-1	AV-600-0-0-1 ^a	—	—
VB-7213-0-4-X	1/2 to 2 in.	AV-391	AV-600-0-0-1	AV-391	AV-393	—	AV-391	AV-393	AV-308-0-0-1	AV-600-0-0-1 ^a	AV-391	AV-630, AV-630-010
VB-7214-0-4-X	1/2 to 2 in.	AV-391	AV-600-0-0-1	AV-391	AV-393	—	AV-391	AV-393	AV-308-0-0-1	AV-600-0-0-1 ^a	AV-391	AV-630, AV-630-010
VB-7221-0-4-X	1/2 to 1-1/4 in.	—	AV-600-0-0-1	—	—	—	—	—	AV-308-0-0-1	AV-600-0-0-1 ^a	—	—
VB-7222-0-4-X	5/8 in. O.D.	—	AV-600-0-0-1	—	—	—	—	—	AV-308-0-0-1	AV-600-0-0-1 ^a	—	—
VB-7223-0-4-X	1/2 to 2 in.	—	AV-600-0-0-1	—	—	—	—	—	AV-308-0-0-1	AV-600-0-0-1 ^a	—	—
VB-7224-0-4-X	1/2 to 2 in.	—	AV-600-0-0-1	—	—	—	—	—	AV-308-0-0-1	AV-600-0-0-1 ^a	—	—
VB-7253-0-4-X	1/2 to 2 in.	AV-391	AV-600-0-0-1	AV-391	AV-393	AV-671 ^c	AV-391	AV-393	AV-308-0-0-1	AV-600-0-0-1 ^a	AV-391	AV-630, AV-630-010
VB-7263-0-4-X	1/2 to 2 in.	—	AV-600-0-0-1	—	—	—	—	—	AV-308-0-0-1	AV-600-0-0-1 ^a	—	—
VB-7273-0-4-X	1/2 to 2 in.	AV-391	AV-600-0-0-1	AV-391	AV-393	AV-671 ^c	AV-391	AV-393	AV-308-0-0-1	AV-600-0-0-1 ^a	AV-391	AV-630, AV-630-010
VB-7283-0-4-X	1/2 to 2 in.	—	AV-600-0-0-1	—	—	—	—	—	AV-308-0-0-1	AV-600-0-0-1 ^a	—	—
VB-7312-0-4-X	5/8 in. O.D.	—	AV-600-0-0-1	—	—	—	—	—	AV-308-0-0-1	AV-600-0-0-1 ^a	—	—
VB-7313-0-4-X	1/2 to 2 in.	AV-391	AV-600-0-0-1	AV-391	AV-393	AV-671 ^c	AV-391	AV-393	AV-308-0-0-1	AV-600-0-0-1 ^a	AV-391	AV-630, AV-630-010
VB-7314-0-4-X	1/2 to 2 in.	AV-391	AV-600-0-0-1	AV-391	AV-393	—	AV-391	AV-393	AV-308-0-0-1	AV-600-0-0-1 ^a	AV-391	AV-630, AV-630-010

Valve Body Part Number	Valve Sizes	ACTUATOR PART NUMBER										
		Electric/Electronic										
		MA-3X8-XXX MA-416-XXX MA-4X8-XXX MA-4X9-XXX	MA-521X-XXX	MC-31X MC-32X MC-41X MC-41X1	All MC-3XX, 4XX, 4XXX Except Those in Preceding Column	MF-631X3	MP-32X, 33X, 36X, 37X, 42XX, 43XX, 46XX, 47XX, 21XX (180° Models Only)	MP-34X, 35X, 38X, 44XX, 45XX, 48XX (180° Models Only)	MP-503 MP-513 MU-503 MU-504 MU-506	MF-5X1X, MP-521X-XXX, MP-54XX, MP-55XX, MPR-561X, MPR-571X, MPR-581X	MU-4610X MU-4710X	MM/MMR-400 MM/MMR-500
VB-7323-0-4-X	1/2 to 2 in.	AV-391	AV-600-0-0-1	AV-391	AV-393	—	AV-391	AV-393	AV-308-0-0-1	AV-600-0-0-1 ^a	AV-391	AV-630, AV-630-010
VB-7332-0-4-X	5/8 in. O.D.	—	—	—	—	—	—	—	AV-308-0-0-1	AV-600-0-0-1 ^a	—	—
VB-9211-0-4-X	1/2 to 1-1/4 in.	—	AV-600-0-0-1	—	—	AV-671 ^e	—	—	AV-308-0-0-1	AV-600-0-0-1 ^a	—	—
VB-9212-0-4-X	5/8 in. O.D.	—	AV-600-0-0-1	—	—	—	—	—	AV-308-0-0-1	AV-600-0-0-1 ^a	—	—
VB-9213-0-4-X	1/2 to 1-1/4 in.	AV-391	AV-600-0-0-1	AV-391	AV-393	—	AV-391	AV-393	AV-308-0-0-1	AV-600-0-0-1 ^a	AV-391	AV-630, AV-630-010
VB-9213-0-4-X	1-1/2 & 2 in.	AV-392	—	AV-392	AV-394	†	AV-392	AV-394	—	—	AV-392	AV-630, AV-630-020
VB-9213-0-4-X	2-1/2 & 3 in.	AV-395	—	AV-395	AV-396, AV-352	AV-672	AV-395	AV-396 & AV-352	—	—	AV-395	AV-630, AV-630-030
VB-9213-0-5-X	2-1/2 to 4 in.	AV-395	—	AV-395	AV-396, AV-352	AV-672	AV-395	AV-396, AV-352	—	—	AV-395	AV-630, AV-630-030
VB-9213-0-5-X	5 & 6 in.	—	—	—	AV-352	—	—	AV-352	—	—	—	—
VB-9214-0-4-X	1/2 to 1-1/4 in.	AV-391	AV-600-0-0-1	AV-391	AV-393	—	AV-391	AV-393	AV-308-0-0-1	AV-600-0-0-1 ^a	AV-391	AV-630, AV-630-010
VB-9214-0-4-X	1-1/2 & 2 in.	AV-392	—	AV-392	AV-394	—	AV-392	AV-394	—	—	AV-392	AV-630, AV-630-020
VB-9215-0-4-X	15 to 32 mm	AV-391	AV-600-0-0-1	AV-391	AV-393	—	AV-391	AV-393	AV-308-0-0-1	AV-600-0-0-1 ^a	AV-391	AV-630, AV-630-010
VB-9215-0-4-X	40 to 50 mm	AV-392	—	AV-392	AV-394	†	AV-392	AV-394	—	—	AV-392	AV-630, AV-630-020
VB-9215-0-4-X	65 to 80 mm	AV-395	—	AV-395	AV-396, AV-352	AV-672	AV-395	AV-396 & AV-352	—	—	AV-395	AV-630, AV-630-030
VB-9221-0-4-X	1/2 to 1-1/4 in.	—	AV-600-0-0-1	—	—	—	—	—	AV-308-0-0-1	AV-600-0-0-1 ^a	—	—
VB-9222-0-4-X	5/8 in. O.D.	—	AV-600-0-0-1	—	—	—	—	—	AV-308-0-0-1	AV-600-0-0-1 ^a	—	—
VB-9223-0-4-X	1/2 to 1-1/4 in.	—	AV-600-0-0-1	—	—	—	—	—	AV-308-0-0-1	AV-600-0-0-1 ^a	—	—
VB-9223-0-4-X	1-1/2 to 2 in.	—	—	—	—	—	—	—	—	—	—	—
VB-9223-0-4-X	2-1/2 & 3 in.	—	—	—	—	—	—	—	—	—	—	—
VB-9223-0-5-X	2-1/2 to 4 in.	—	—	—	—	—	—	—	—	—	—	—
VB-9223-0-5-4	5 to 6 in.	—	—	—	AV-352	—	—	AV-352	—	—	—	—
VB-9224-0-4-X	1/2 to 1-1/4 in.	—	AV-600-0-0-1	—	—	—	—	—	AV-308-0-0-1	AV-600-0-0-1 ^a	—	—
VB-9224-0-4-X	1-1/2 & 2 in.	—	—	—	—	—	—	—	—	—	—	—
VB-9253-0-4-X	1/2 to 1-1/4 in.	AV-391	AV-600-0-0-1	AV-391	AV-393	AV-671 ^c	AV-391	AV-393	AV-308-0-0-1	AV-600-0-0-1 ^a	AV-391	AV-630, AV-630-010
VB-9253-0-4-X	1-1/2 & 2 in.	AV-392	—	AV-392	AV-394	†	AV-392	AV-394	—	—	AV-392	AV-630, AV-630-020
VB-9263-0-4-X	1/2 to 1-1/4 in.	—	AV-600-0-0-1	—	—	—	—	—	AV-308-0-0-1	AV-600-0-0-1 ^a	—	—
VB-9263-0-4-X	1-1/2 & 2 in.	—	—	—	—	—	—	—	—	—	—	—
VB-9273-0-4-X	1/2 to 1-1/4 in.	AV-391	AV-600-0-0-1	AV-391	AV-393	AV-671 ^c	AV-391	AV-393	AV-308-0-0-1	AV-600-0-0-1 ^a	AV-391	AV-630, AV-630-010
VB-9273-0-4-X	1-1/2 & 2 in.	AV-392	—	AV-392	AV-394	†	AV-392	AV-394	—	—	AV-392	AV-630, AV-630-010
VB-9283-0-4-X	1/2 to 1-1/4 in.	—	AV-600-0-0-1	—	—	—	—	—	AV-308-0-0-1	AV-600-0-0-1 ^a	—	—
VB-9283-0-4-X	1-1/2 & 2 in.	—	—	—	—	—	—	—	—	—	—	—
VB-9312-0-4-X	5/8 in. O.D.	—	AV-600-0-0-1	—	—	—	—	—	AV-308-0-0-1	AV-600-0-0-1 ^a	—	—
VB-9313-0-4-X	1/2 to 1-1/4 in.	AV-391	AV-600-0-0-1	AV-391	AV-393	AV-671 ^c	AV-391	AV-393	AV-308-0-0-1	AV-600-0-0-1 ^a	AV-391	AV-630, AV-630-010
VB-9313-0-4-X	1-1/2 & 2 in.	AV-392	—	AV-392	AV-394	†	AV-392	AV-394	—	—	AV-392	AV-630, AV-630-020
VB-9313-0-4-X	2-1/2 & 3 in.	AV-395	—	AV-395	AV-396, AV-352	AV-672	AV-395	AV-396, AV-352	—	—	AV-395	AV-630, AV-630-030
VB-9313-0-5-X	2-1/2 to 4 in.	AV-395	—	AV-395	AV-396, AV-352	AV-672	AV-395	AV-396, AV-352	—	—	AV-395	AV-630, AV-630-030
VB-9313-0-5-X	5 to 6 in.	—	—	—	AV-352	—	—	AV-352	—	—	—	—
VB-9314-0-4-X	1/2 to 1-1/4 in.	AV-391	AV-600-0-0-1	AV-391	AV-393	—	AV-391	AV-393	AV-308-0-0-1	AV-600-0-0-1 ^a	AV-391	AV-630, AV-630-010
VB-9314-0-4-X	1-1/2 & 2 in.	AV-392	—	AV-392	AV-394	—	AV-392	AV-394	—	—	AV-392	AV-630, AV-630-020
VB-9315-0-4-X	15 to 32 mm	AV-391	AV-600-0-0-1	AV-391	AV-393	AV-671 ^c	AV-391	AV-393	AV-308-0-0-1	AV-600-0-0-1 ^a	AV-391	AV-630, AV-630-010
VB-9315-0-4-X	40 to 50 mm	AV-392	—	AV-392	AV-394	†	AV-392	AV-394	—	—	AV-392	AV-630, AV-630-020
VB-9315-0-4-X	65 to 80 mm	AV-395	—	AV-395	AV-396, AV-352	AV-672	AV-395	AV-396, AV-352	—	—	AV-395	AV-630, AV-630-030

Linkages

Valve Body Part Number	Valve Sizes	ACTUATOR PART NUMBER										
		Electric/Electronic										
		MA-3X8-XXX MA-416-XXX MA-4X8-XXX MA-4X9-XXX	MA-521X-XXX	MC-31X MC-32X MC-41X MC-41X1	All MC-3XX, 4XX, 4XXX Except Those in Preceding Column	MF-631X3	MP-32X, 33X, 36X, 37X, 42XX, 43XX, 46XX, 47XX, 21XX (180° Models Only)	MP-34X, 35X, 38X, 44XX, 45XX, 48XX (180° Models Only)	MP-503 MP-513 MU-503 MU-504 MU-506	MF-5X1X, MP-521X-XXX, MP-54XX, MP-55XX, MPR-561X, MPR-571X, MPR-581X	MU-4610X MU-4710X	MM/MMR-400 MM/MMR-500
VB-9323-0-4-X	1/2 to 1-1/4 in.	AV-391	AV-600-0-0-1	AV-391	AV-393	—	AV-391	AV-393	AV-308-0-0-1	AV-600-0-0-1 ^a	AV-391	AV-630, AV-630-010
VB-9323-0-4-X	1-1/2 & 2 in.	AV-392	—	AV-392	AV-394	—	AV-392	AV-394	—	—	AV-392	AV-630, AV-630-020
VB-9323-0-5-X	2-1/2 & 3 in.	AV-300 & AV-29	—	AV-300 & AV-29	AV-300 & AV-30	—	AV-300 & AV-29	AV-300 & AV-30	—	—	AV-300 & AV-29	AV-630, AV-630-040
VB-9323-0-5-X	4 to 6 in.	—	—	—	AV-352	—	AV-352	AV-352	—	—	—	—
VB-9332-0-4-X	5/8 in. O.D.	—	—	—	—	—	—	—	AV-308-0-0-1	AV-600-0-0-1 ^a	—	—
OYBB-233	1/2 & 3/4 in.	—	AV-600	—	—	—	—	—	AV-308	AV-600 ^a	—	—

^a Use AV-601 for high fluid temperature applications; see specific valve for temperature limitations.

^b Some valves used AV-327 neutral band linkages and will require AV-327. These linkages can be identified by the cam being marked with the number "49". AV-327 were used on heating valves when the auxiliary switch(es) were controlling D.X. compressor.

^c Supplied with actuator.

^e Supplied with actuator.

^f Direct mount; no separate linkage.

NOTE:

AV-600-0-0-1 can replace AV-600.

AV-430-0-0-1 can replace AV-430.

AV-308-0-0-1 can replace AV-308.

Valve Body Part Number	Valve Sizes	ACTUATOR PART NUMBER									
		Electric/Electronic			Pneumatic						
		MU-4810X	MUP-4610X MUP-4710X	MUP-4820X	MK-2690	MK-46X1	MK-47X1 (Obsolete)	MK-48X1	MK-68X1 (MK-69X1 is only used on VB-817 & VB-9323, 4 to 6 in.)	MK-88XX (2-1/2 to 4 in.)	MK-89XX (5 & 6 in.)
VB-111-0-X-X	1/2 to 1-1/4 in.	—	—	—	AV-400	AV-404	—	—	—	—	—
VB-121-0-X-X	1/2 in. O.D.	—	—	—	AV-400	AV-401	—	—	—	—	—
VB-131-X-X-X	5/8 or 7/8 in. O.D.	—	—	—	AV-400	AV-401	—	—	—	—	—
VB-151-0-1-X	1/2 to 1-1/4 in.	—	—	—	AV-400	AV-401	—	—	—	—	—
VB-202-0-1-X	1/2 to 2 in.	AV-300 & AV-30 ^a	AV-300 & AV-21	AV-300 & AV-30 ^a	—	—	AV-430	—	AV-430	—	—
VB-202-0-2-X	2-1/2 to 4 in.	AV-300 & AV-30	AV-300 & AV-29	AV-300 & AV-30	—	—	—	—	AV-430	AV-496 ^b	—
VB-202-0-2-X	5 & 6 in.	AV-352	—	AV-352	—	—	—	—	—	—	AV-496
VB-212-0-1-X	1/2 to 2 in.	AV-300 & AV-30 ^a	AV-300 & AV-21	AV-300 & AV-30 ^a	—	—	AV-430	—	AV-430	—	—
VB-222-0-1-1,2,3,5,7	1/2 & 3/4 in.	AV-347-10	AV-347	AV-347-10	—	—	—	—	AV-442	—	—
VB-222-0-X-6,8,10	3/4, 1 & 1-1/2 in.	AV-347-30	AV-347-20	AV-347-30	—	—	—	—	AV-443	—	—
VB-252-0-1-X	1/2 to 2 in.	—	—	—	—	—	AV-430	—	AV-430	—	—
VB-252-0-2-X	2-1/2 to 4 in.	—	—	—	—	—	—	—	AV-430	AV-496 ^b	—
VB-260-0-1-X	1/2 & 3/4 in.	—	—	—	—	—	—	—	—	—	—
VB-260-0-1-X	1 to 1-1/2 in.	—	—	—	—	—	—	—	—	—	—
VB-262-0-1-X	1/2 to 1-1/2 in.	AV-300 & AV-30	—	AV-300 & AV-30	—	—	—	—	—	—	—
VB-314-0-1-X	1/2 to 1 in.	—	—	—	AV-400	AV-401	—	—	—	—	—
VB-324-0-5-4	1/2 in. O.D.	—	—	—	AV-400	AV-401	—	—	—	—	—
VB-334-0-5-4	1/2 in. O.D.	—	—	—	AV-400	AV-401	—	—	—	—	—
VB-354-0-5-X	5/8 or 7/8 in. O.D.	—	—	—	AV-400	AV-401	—	—	—	—	—
VB-804-0-1-X	1/2 to 2 in.	AV-300 & AV-30 ^a	AV-300 & AV-21	AV-300 & AV-30 ^a	—	—	AV-430	—	AV-430	—	—
VB-804-0-2-X	2-1/2 to 4 in.	AV-300 & AV-30	AV-300 & AV-29	AV-300 & AV-30	—	—	—	—	AV-430	AV-496 ^b	—
VB-804-0-2-X	5 & 6 in.	AV-352	—	AV-352	—	—	—	—	—	—	AV-496
VB-807-0-1-X	1/2 to 2 in.	AV-300 & AV-30	AV-300 & AV-21	AV-300 & AV-30	—	—	AV-430	—	AV-430	—	—
VB-817-0-X-X	1/2 to 3 in.	AV-300 & AV-30	AV-300 & AV-29	AV-300 & AV-30	—	—	—	—	AV-430	—	—
VB-817-0-X-X	4 to 6 in.	AV-352	—	AV-352	—	—	—	—	AV-430	—	—
VB-7211-0-4-X	1/2 to 1-1/4 in.	—	—	—	AV-430	AV-401	—	—	—	—	—
VB-7212-0-4-X	5/8 in. O.D.	—	—	—	AV-400	AV-401	—	—	—	—	—
VB-7213-0-4-X	1/2 to 2 in.	AV-393	AV-391	AV-393	AV-400	AV-401	AV-430-0-0-1	—	—	—	—
VB-7214-0-4-X	1/2 to 2 in.	AV-393	AV-391	AV-393	AV-400	AV-401	AV-430-0-0-1	—	—	—	—
VB-7221-0-4-X	1/2 to 1-1/4 in.	—	—	—	AV-400	AV-401	—	—	—	—	—
VB-7222-0-4-X	5/8 in. O.D.	—	—	—	AV-400	AV-401	—	—	—	—	—
VB-7223-0-4-X	1/2 to 2 in.	AV-393	AV-391	AV-393	AV-400	AV-401	AV-430-0-0-1	—	—	—	—
VB-7224-0-4-X	1/2 to 2 in.	AV-393	AV-391	AV-393	AV-400	AV-401	AV-430-0-0-1	—	—	—	—
VB-7253-0-4-X	1/2 to 2 in.	AV-393	AV-391	AV-393	AV-400	AV-401	AV-430-0-0-1	—	—	—	—
VB-7263-0-4-X	1/2 to 2 in.	AV-393	AV-391	AV-393	AV-400	AV-401	AV-430-0-0-1	—	—	—	—
VB-7273-0-4-X	1/2 to 2 in.	AV-393	AV-391	AV-393	AV-400	AV-401	AV-430-0-0-1	—	—	—	—
VB-7283-0-4-X	1/2 to 2 in.	AV-393	AV-391	AV-393	AV-400	AV-401	AV-430-0-0-1	—	—	—	—
VB-7312-0-4-X	5/8 in. O.D.	—	—	—	AV-400	AV-401	—	—	—	—	—
VB-7313-0-4-X	1/2 to 2 in.	AV-393	AV-391	AV-393	AV-400	AV-401	AV-430-0-0-1	—	—	—	—
VB-7314-0-4-X	1/2 to 2 in.	AV-393	AV-391	AV-393	AV-400	AV-401	AV-430-0-0-1	—	—	—	—
VB-7323-0-4-X	1/2 to 2 in.	AV-393	AV-391	AV-393	AV-400	AV-401	AV-430-0-0-1	—	—	—	—
VB-7332-0-4-X	5/8 in. O.D.	—	—	—	AV-400	AV-401	—	—	—	—	—

Linkages

Valve Body Part Number	Valve Sizes	ACTUATOR PART NUMBER									
		Electric/Electronic			Pneumatic						
		MU-4810X	MUP-4610X MUP-4710X	MUP-4820X	MK-2690	MK-46X1	MK-47X1 (Obsolete)	MK-48X1	MK-68X1 (MK-69X1 is only used on VB-817 & VB-9323, 4 to 6 in.)	MK-88XX (2-1/2 to 4 in.)	MK-89XX (5 & 6 in.)
VB-9211-0-4-X	1/2 to 1-1/4 in.	—	—	—	AV-430	AV-401	—	—	—	—	—
VB-9212-0-4-X	5/8 in. O.D.	—	—	—	AV-400	AV-401	—	—	—	—	—
VB-9213-0-4-X	1/2 to 1-1/4 in.	AV-393	AV-391	AV-393	AV-400	AV-401	AV-430-0-0-1	—	—	—	—
VB-9213-0-4-X	1-1/2 & 2 in.	AV-394	AV-392	AV-394	—	—	AV-430-0-0-1	AV-420	AV-430-0-0-1	—	—
VB-9213-0-4-X	2-1/2 & 3 in.	AV-396, AV-352	AV-395	AV-396, AV-352	—	—	—	—	AV-495	AV-496	—
VB-9213-0-5-X	2-1/2 to 4 in.	AV-396, AV-352	AV-395	AV-396, AV-352	—	—	—	—	AV-495	AV-496	—
VB-9213-0-5-X	5 & 6 in.	AV-352	—	AV-352	—	—	—	—	—	—	AV-496
VB-9214-0-4-X	1/2 to 1-1/4 in.	AV-393	AV-391	AV-393	AV-400	AV-401	AV-430-0-0-1	—	—	—	—
VB-9214-0-4-X	1-1/2 & 2 in.	AV-394	AV-392	AV-394	—	—	AV-430-0-0-1	AV-420	AV-430-0-0-1	—	—
VB-9215-0-4-X	15 to 32 mm	AV-393	AV-391	AV-393	AV-400	AV-401	AV-430-0-0-1	—	—	—	—
VB-9215-0-4-X	40 and 50 mm	AV-394	AV-392	AV-394	—	—	AV-430-0-0-1	AV-420	AV-430-0-0-1	—	—
VB-9215-0-4-X	65 and 80 mm	AV-396, AV-352	AV-395	AV-396, AV-352	—	—	—	—	AV-495	AV-496	—
VB-9221-0-4-X	1/2 to 1-1/4 in.	—	—	—	AV-400	AV-401	—	—	—	—	—
VB-9222-0-4-X	5/8 in. O.D.	—	—	—	AV-400	AV-401	—	—	—	—	—
VB-9223-0-4-X	1/2 to 1-1/4 in.	AV-393	AV-391	AV-393	AV-400	AV-401	AV-430-0-0-1	—	—	—	—
VB-9223-0-4-X	1-1/2 to 2 in.	AV-394	AV-392	AV-394	—	—	AV-430-0-0-1	AV-420	AV-430-0-0-1	—	—
VB-9223-0-4-X	2-1/2 & 3 in.	AV-396	AV-395	AV-396	—	—	—	—	AV-495	AV-496	—
VB-9223-0-5-X	2-1/2 to 4 in.	AV-396	AV-395	AV-396	—	—	—	—	AV-495	AV-496	—
VB-9223-0-5-4	5 to 6 in.	AV-352	—	AV-352	—	—	—	—	—	—	AV-496
VB-9224-0-4-X	1/2 to 1-1/4 in.	AV-393	AV-391	AV-393	AV-400	AV-401	AV-430-0-0-1	—	—	—	—
VB-9224-0-4-X	1-1/2 & 2 in.	AV-394	AV-392	AV-394	—	—	AV-430-0-0-1	AV-420	AV-430-0-0-1	—	—
VB-9253-0-4-X	1/2 to 1-1/4 in.	AV-393	AV-391	AV-393	AV-400	AV-401	AV-430-0-0-1	—	—	—	—
VB-9253-0-4-X	1-1/2 & 2 in.	AV-394	AV-392	AV-394	—	—	AV-430-0-0-1	AV-420	AV-430-0-0-1	—	—
VB-9263-0-4-X	1/2 to 1-1/4 in.	AV-393	AV-391	AV-393	AV-400	AV-401	AV-430-0-0-1	—	—	—	—
VB-9263-0-4-X	1-1/2 & 2 in.	AV-394	AV-392	AV-394	—	—	AV-430-0-0-1	AV-420	AV-430-0-0-1	—	—
VB-9273-0-4-X	1/2 to 1-1/4 in.	AV-393	AV-391	AV-393	AV-400	AV-401	AV-430-0-0-1	—	—	—	—
VB-9273-0-4-X	1-1/2 & 2 in.	AV-394	AV-392	AV-394	—	—	AV-430-0-0-1	AV-420	AV-430-0-0-1	—	—
VB-9283-0-4-X	1/2 to 1-1/4 in.	AV-393	AV-391	AV-393	AV-400	AV-401	AV-430-0-0-1	—	—	—	—
VB-9283-0-4-X	1-1/2 & 2 in.	AV-394	AV-392	AV-394	—	—	AV-430-0-0-1	AV-420	AV-430-0-0-1	—	—
VB-9312-0-4-X	5/8 in. O.D.	—	—	—	AV-400	AV-401	—	—	—	—	—
VB-9313-0-4-X	1/2 to 1-1/4 in.	AV-393	AV-391	AV-393	AV-400	AV-401	AV-430-0-0-1	—	—	—	—
VB-9313-0-4-X	1-1/2 & 2 in.	AV-394	AV-392	AV-394	—	—	AV-430-0-0-1	AV-420	AV-430-0-0-1	—	—
VB-9313-0-4-X	2-1/2 & 3 in.	AV-396, AV-352	AV-395	AV-396, AV-352	—	—	—	—	AV-495	AV-496	—
VB-9313-0-5-X	2-1/2 to 4 in.	AV-396, AV-352	AV-395	AV-396, AV-352	—	—	—	—	AV-495	AV-496	—
VB-9313-0-5-X	5 to 6 in.	AV-352	—	AV-352	—	—	—	—	—	—	AV-496

Valve Body Part Number	Valve Sizes	ACTUATOR PART NUMBER									
		Electric/Electronic			Pneumatic						
		MU-4810X	MUP-4610X MUP-4710X	MUP-4820X	MK-2690	MK-46X1	MK-47X1 (Obsolete)	MK-48X1	MK-68X1 (MK-69X1 is only used on VB-817 & VB-9323, 4 to 6 in.)	MK-88XX (2-1/2 to 4 in.)	MK-89XX (5 & 6 in.)
VB-9314-0-4-X	1/2 to 1-1/4 in.	AV-393	AV-391	AV-393	AV-400	AV-401	AV-430-0-0-1	—	—	—	—
VB-9314-0-4-X	1-1/2 & 2 in.	AV-394	AV-392	AV-394	—	—	AV-430-0-0-1	AV-420	AV-430-0-0-1	—	—
VB-9315-0-4-X	15 to 32 mm	AV-393	AV-391	AV-393	AV-400	AV-401	AV-430-0-0-1	—	—	—	—
VB-9315-0-4-X	40 and 50 mm	AV-394	AV-392	AV-394	—	—	AV-430-0-0-1	AV-420	AV-430-0-0-1	—	—
VB-9315-0-4-X	65 and 80 mm	AV-396, AV-352	AV-395	AV-396, AV-352	—	—	—	—	AV-495	AV-496	—
VB-9323-0-4-X	1/2 to 1-1/4 in.	AV-393	AV-391	AV-393	AV-400	AV-401	AV-430-0-0-1	—	—	—	—
VB-9323-0-4-X	1-1/2 & 2 in.	AV-394	AV-392	AV-394	—	—	AV-430-0-0-1	AV-420	AV-430-0-0-1	—	—
VB-9323-0-5-X	2-1/2 & 3 in.	AV-300 & AV-30	AV-300 & AV-29	AV-300 & AV-30	—	—	—	—	AV-430-0-0-1	—	—
VB-9323-0-5-X	4 to 6 in.	AV-352	—	AV-352	—	—	—	—	AV-430-0-0-1	—	—
VB-9332-0-4-X	5/8 in. O.D.	—	—	—	AV-400	AV-401	—	—	—	—	—
OYBB-233	1/2 & 3/4 in.	—	—	—	AV-400	AV-401	—	—	—	—	—

^a Some valves used AV-327 neutral band linkages and will require AV-327. These linkages can be identified by the cam being marked with the number "49". AV-327 were used on heating valves when the auxiliary switch(es) were controlling D.X. compressor.

^b Requires XYBB-252 and NYBA-59.

NOTE:
 AV-600-0-0-1 can replace AV-600.
 AV-430-0-0-1 can replace AV-430.
 AV-308-0-0-1 can replace AV-308.

Valve Linkages

Application

For assembling electric gear train actuators to valve bodies.

The AV-390 through AV-396 linkages are used to field assemble Siebe Environmental Controls gear train actuators and VB-9XXX and VB-7XXX series of valve bodies.

Features:

- Die case aluminum mounting bracket.
- Valve position indication provided as standard.

Specifications

- Actuator mounting: In any upright position with actuator above the center line of the valve body.

Siebe Model No.	Description	Minimum Actuator Torque Required (Actuator must be 180° Stroke) (lb-in.)	Stem Force (lb)
AV-29	Cam, Plunger and Connection Pin Kit	50	150
AV-30		100	300
AV-91	Cam, Plunger and Stem Extension Kit	40	150
AV-92 ^a		50	150
AV-93		70	300
AV-94 ^b		100	300
AV-300	Common Parts Kits Req. AV-29, 30	—	—
AV-347	Complete Linkage	50	150
AV-347-10		100	300
AV-347-20		50	150
AV-347-30		100	300
AV-390	Common Parts Kits Req. AV-91, 92, 93, 94	—	—
AV-391	Complete Linkages	40	150
AV-392 ^a		50	150
AV-393		70	300
AV-394 ^b		100	300
AV-395		50	150
AV-396		100	300

^a Used on obsolete 1-1/2 & 2" VB-9XXX valves with spring return actuators only.

^b Used on obsolete 1-1/2 & 2" VB-9XXX valves with non-spring return actuators only.

AV-29, AV-30, AV-9X Series, AV-300, AV-347, AV-39X Series Electric/Electronic Valve Linkage Kits

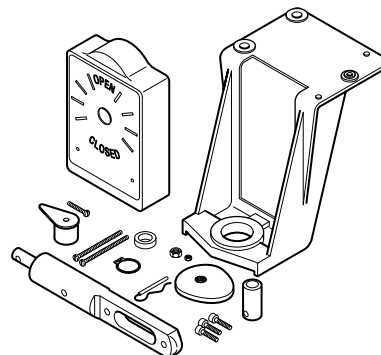

Valve Linkages

Application

The AV-352 valve linkage is used to field-install gear train actuators on specified 2-1/2 to 6 in. valve bodies.

Features:

- Compatible with SiebeEnvironmental Controls (Barber-Colman) 2-1/2 to 6 in. valves.
- Provides increased close-off pressure on 2-1/2 to 4 in. valves.
- Required for rated close-off pressure on 5 and 6 in. valves.

Specifications

- Actuator mounting: In any upright position with actuator above the center line of the valve body.
- Minimum actuator torque required: 220 lb-in.
- Actuator travel required: 180°.

AV-352

Gear Train Actuator Valve Linkage

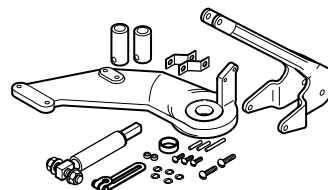

Application

For assembling MP-9000 Series gear train actuators to 4 to 6 in. VB-9213 and VB-9313 valve bodies.

Specifications

- Actuator mounting: In any upright position with actuator above the center line of the valve body.

AV-358

Electric/Electronic Valve Linkage Kits

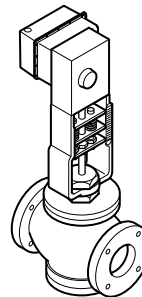

Valve Linkages

Application

For assembling EA81 Series hydraulic actuator to (1/2 to 1-1/4 in.) VB-7XXX and obsolete VB-9XXX valve bodies. Device consists of spring retainer, spring and combination stem extension and lock nut. TOOL-19 spring compression tool is recommended for assembly.

Specifications

- Actuator mounting: In any upright position above the center line of the valve body. For steam applications only, mount the actuator above the valve body at 45° from vertical.

AV-600 Electric/Electronic Valve Linkage Kit

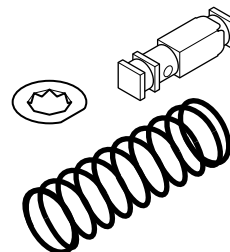

Application

The AV-601 valve extension kit is used to increase the allowable ambient temperature ratings of EA81 Series actuator on applications with hot water or steam. The MF-5X1X, MP-541X, and MPR-5X1X Series of actuators require the AV-601 extension.

Specifications

- Kit consists of an extension coupling and a spacer.
- Dimensions: Add 2-1/32 in. (52 mm) to the "E" dimension for the valve assembly using an AV-601 linkage extension. Refer to complete dimensions:
 - Two-Way Valves, Union End and Flared.
 - Two-Way Valves, Screwed and Flanged.
 - Three-Way Mixing and Sequencing Valves, Flared.
 - Three-Way Mixing and Diverting Valves, Screwed.

AV-601 Electric/Electronic Valve Linkage Extension Kit

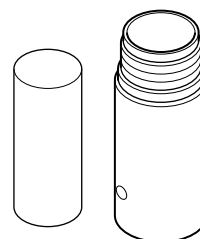

Restrictions on Maximum Ambient Temperature for Valve Actuators

Maximum Temperature of Media in Valve Body °F (°C) (Check Rating of Valve)	Maximum Ambient Temperature at Actuator °F (°C)	
	EA81	
	Without AV-601	With AV-601
366 (180)	90 (32)	90 (32)
340 (171)	100 (38)	100 (38)
281 (138)	115 (46)	140 (60) ^a
181 (83)	140 (60) ^a	140 (60) ^a
140 (60)	140 (60) ^a	140 (60) ^a

^a Maximum allowable ambient temperature of the actuator.

Valve Linkages

Application

For mounting MF-60000 Series actuators on 2-1/2, 3, or 4 in. VB-921X and VB-931X valves.

Features:

- Provides direct couple interface between MF-60000 actuator and 2-1/2 to 4 in. valve.

Specifications

- Actuator mounting: In any upright position with actuator above the center line of the valve body.

AV-672

Electric/Electronic Valve Linkage Kit

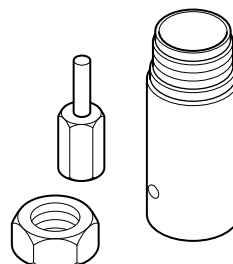

Application

For mounting MF-60000 Series actuators on Johnson Controls 1/2 through 2 in. VB-3754, VB-3924, and VB-4324 valves.

Features:

- Provides direct couple interface between MF-631X3 actuator and 1/2 through 2 in. Johnson Controls VB-3754, VB-3924, and VB-4324 valves.

Specifications

- Actuator mounting: In any upright position with actuator above the center line of the valve body.

AV-673

Electric/Electronic Valve Linkage Kit

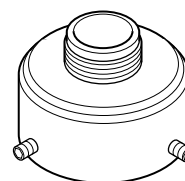

Close-Off Rating

Two-Way Valves

Johnson Controls Valve Body	P Code	Size in.	MF-631X3 Close-Off Pressure Ratings psig	
VB-3754 (Push Down to Close)	-1	1/2	150	
	-2			
	-3			
	-4	3/4		
VB-3974 (Push Down to Open)	-5	1		
	-6	1-1/2		95
	-7	2		55

Three-Way Valves

Johnson Controls Valve Body	P Code	Size in.	Close-Off Pressure Ratings	
VB-4324 (Three-Way Mixing)	-1	1/2	150	
	-2			
	-3			
	-4	3/4		
	-5	1		
	-6	1-1/2		95
	-7	2		55

Valve Linkages

AV-674

Electric/Electronic Valve Linkage Kit

Application

For mounting MF-60000 Series actuators on 1/2 to 3 in. Honeywell 3/4 in. stroke valves.

Features:

- Provides direct couple interface between MF-631X3 actuator and 1/2 to 3 in. Honeywell 3/4 in. stroke valve.

Specifications

- Actuator mounting: In any upright position with actuator above the center line of the valve body.

Close-Off Rating

Two-Way Valves

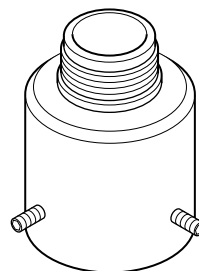

Honeywell Valve Body	Size in.	Close-Off Pressure Ratings psig
V5011F (Screwed)	1/2	150
	3/4	
	1	
	1-1/4	
	1-1/2	123
	2	75
	2-1/2	44
V5011G (Screwed, Comp. Disc)	3	27
	2	75
	2-1/2	44
V5011G (Screwed, Metal-to-Metal Seating)	3	27
	1/2	150
	3/4	
	1	
	1-1/4	
1-1/2	123	

Three-Way Valves

Honeywell Valve Body	Size in.	Close-Off Pressure Ratings psig
V5013F (Screwed, Mixing)	1/2	150
	3/4	
	1	
	1-1/4	
	1-1/2	137
	2	96

Warranty

Products are warranted according to the General Warranty Statement that is part of the Terms and Conditions of Sale of the Industrial Instruments Division (Literature Part No. 0001-GI-015-0-XX), Barber-Colman Company.



a Siebe company

Barber-Colman Company
Industrial Instruments Division